



# Wayfinding Plan

- Programming
  - Standards
  - Sign Drawings
- Placement Guidelines
  - Usage Guidelines
- Fabrication Guidelines
  - Process Flowchart
  - Destinations

June 2024



# CVTA Wayfinding for Fall Line Trail

Programming



1005 Stonemill Road  
Richmond, Virginia 23233  
Phone: 804-346-4771  
Fax: 804-325-1751  
[www.abdesignonline.com](http://www.abdesignonline.com)

June 2024



# CVTA Wayfinding for Fall Line Trail

Programming  
Ashland/Hanover



10005 Stonemill Road  
Richmond, Virginia 23233  
Phone: 804-346-4771  
Fax: 804-325-1751  
[www.abdesignonline.com](http://www.abdesignonline.com)



**PROGRAMMING**  
Sign Location Plan  
Hanover

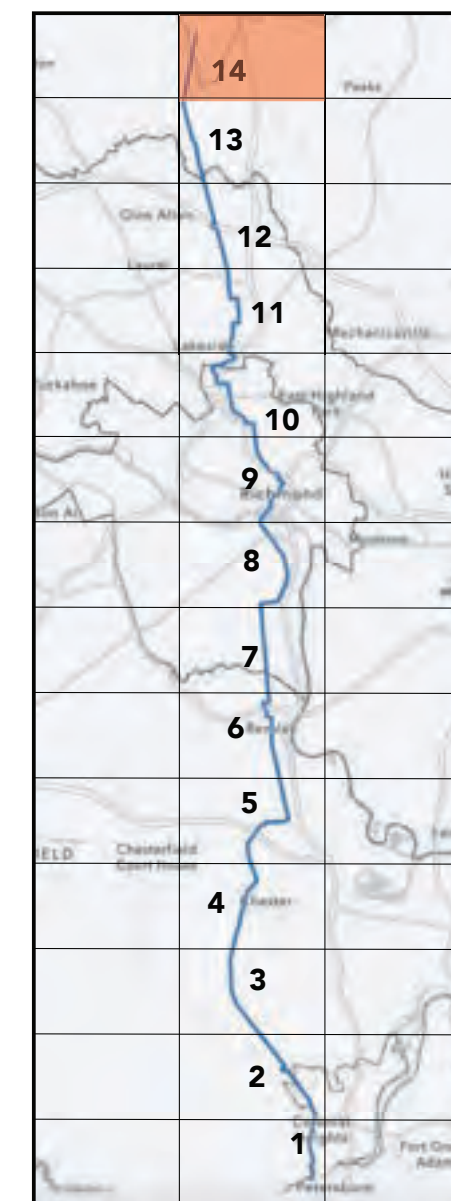

**SIGNTYPES KEY**

ID	Landmark Id.
M	Mile marker
P	Pedestrian Directional
PL	Plate
T	Trailhead Sign
U	Urban/ParkingMarker
V	Vehicular Directional
W	Directional
●	Trail Access Point

THIS DRAWING REPRESENTS DESIGN INTENT ONLY.

Date	Revisions	Scale
11.6.23	12.4.23 5.7.24	NTS
	1.10.24	
	3.8.24	

Client/Project  
CVTA, Virginia  
Wayfinding for Fall Line Trail

**HA.1**



PROGRAMMING

Sign Types  
Hanover



Sign Type T2.1A  
Pedestrian Trailhead/  
Regulatory Sign



Sign Type T2.1B  
Pedestrian Trailhead/  
Regulatory Sign

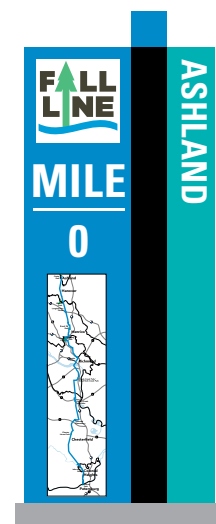

Sign Type M.0  
Mile Marker



Sign Type W.1A  
Directional Sign



W.1B  
Directional Sign

THIS DRAWING REPRESENTS DESIGN INTENT ONLY.

Date	Revisions	Scale
11.6.23	12.4.23 1.10.24 5.7.24 5.30.24 3.8.24	3/4"=1'

Client/Project  
CVTA, Virginia  
Wayfinding for Fall Line Trail

PROGRAMMING  
Sign Types  
Hanover

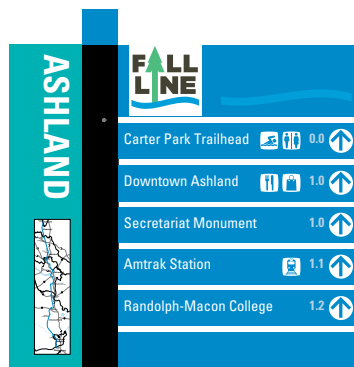

Sign Type P2.1A  
Pedestrian Directional

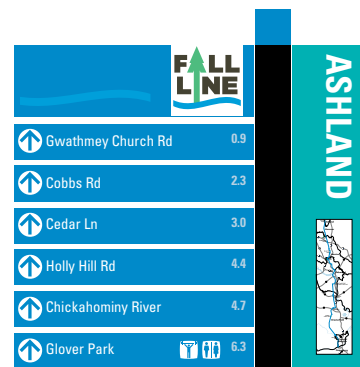

Sign Type P2.1B  
Pedestrian Directional

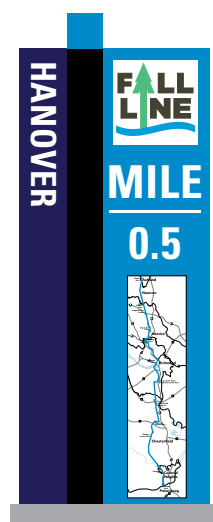

Sign Type M.0.5  
Mile Marker



Sign Type W.2A  
Directional Sign



W.2B  
Directional Sign

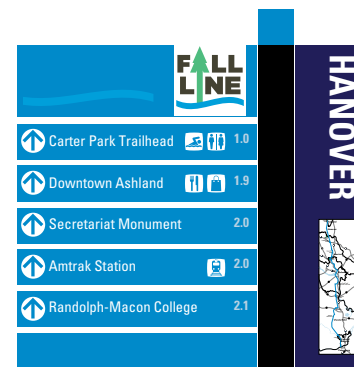

Sign Type P2.2A  
Pedestrian Directional

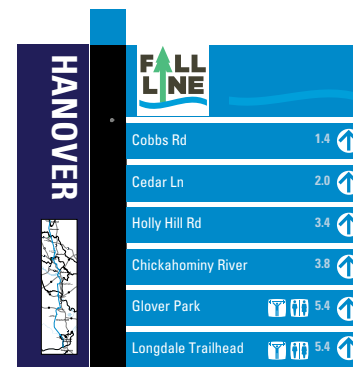

Sign Type P2.2B  
Pedestrian Directional

THIS DRAWING REPRESENTS DESIGN INTENT ONLY.

Date	Revisions	Scale
11.6.23	12.4.23 5.7.24 1.10.24 5.30.24 3.8.24	3/4"=1'

Client/Project  
CVTA, Virginia  
Wayfinding for Fall Line Trail

© 2024 AB Design, Inc.



**PROGRAMMING**  
**Sign Location Plan**  
**Hanover**

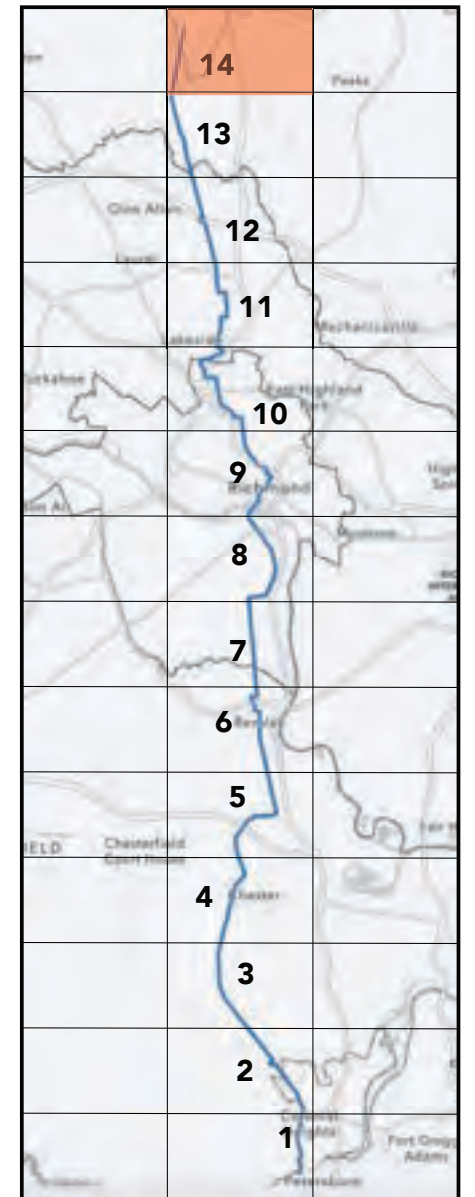

**SIGNTYPES KEY**

- ID Landmark Id.
- M Mile marker
- P Pedestrian Directional
- PL Plate
- T Trailhead Sign
- U Urban/ParkingMarker
- V Vehicular Directional
- W Directional
- Trail Access Point

THIS DRAWING REPRESENTS DESIGN INTENT ONLY.

Date 1.10.24	Revisions 3.11.24 5.7.24 5.30.24	Scale NTS
-----------------	---	--------------

Client/Project  
 CVTA, Virginia  
 Wayfinding for Fall Line Trail

© 2024 AB Design, Inc.

**HA.4**



**PROGRAMMING**  
Sign Location Plan  
Hanover

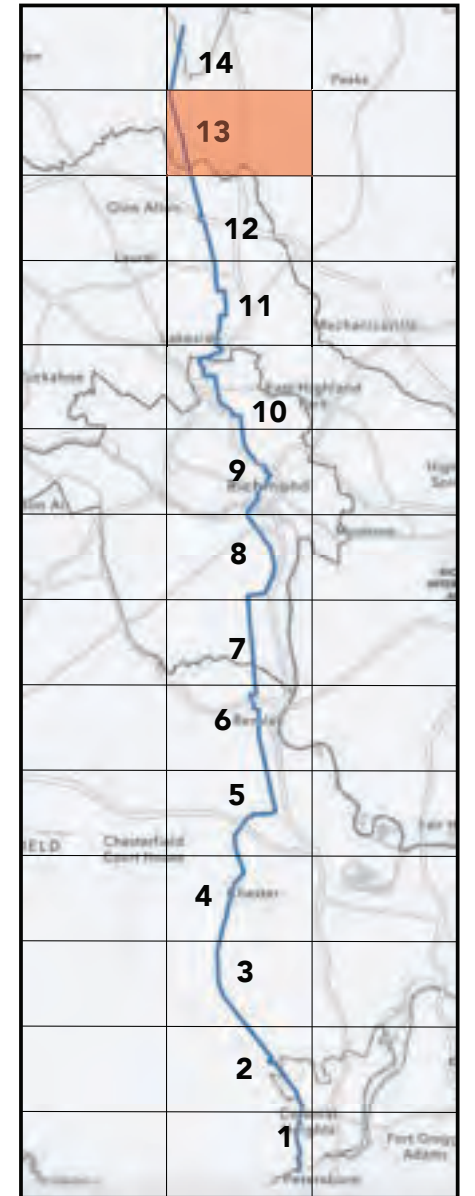

**SIGNTYPES KEY**

<span style="background-color: #f08080; border: 1px solid black; padding: 2px;">ID</span>	Landmark Id.
<span style="background-color: #0070c0; border: 1px solid black; padding: 2px;">M</span>	Mile marker
<span style="background-color: #e91e63; border: 1px solid black; padding: 2px;">P</span>	Pedestrian Directional
<span style="background-color: #ff9933; border: 1px solid black; padding: 2px;">PL</span>	Plate
<span style="background-color: #00b050; border: 1px solid black; padding: 2px;">T</span>	Trailhead Sign
<span style="background-color: #90ee90; border: 1px solid black; padding: 2px;">U</span>	Urban/ParkingMarker
<span style="background-color: #6a3d9a; border: 1px solid black; padding: 2px;">V</span>	Vehicular Directional
<span style="background-color: #9370db; border: 1px solid black; padding: 2px;">W</span>	Directional
<span style="background-color: #32cd32; border: 1px solid black; border-radius: 50%; padding: 2px; display: inline-block; width: 10px; height: 10px;"></span>	Trail Access Point

THIS DRAWING REPRESENTS DESIGN INTENT ONLY.

Date 1.10.24	Revisions 3.11.24 5.7.24	Scale NTS
-----------------	--------------------------------	--------------

Client/Project  
CVTA, Virginia  
Wayfinding for Fall Line Trail

© 2024 AB Design, Inc.

**HA.5**

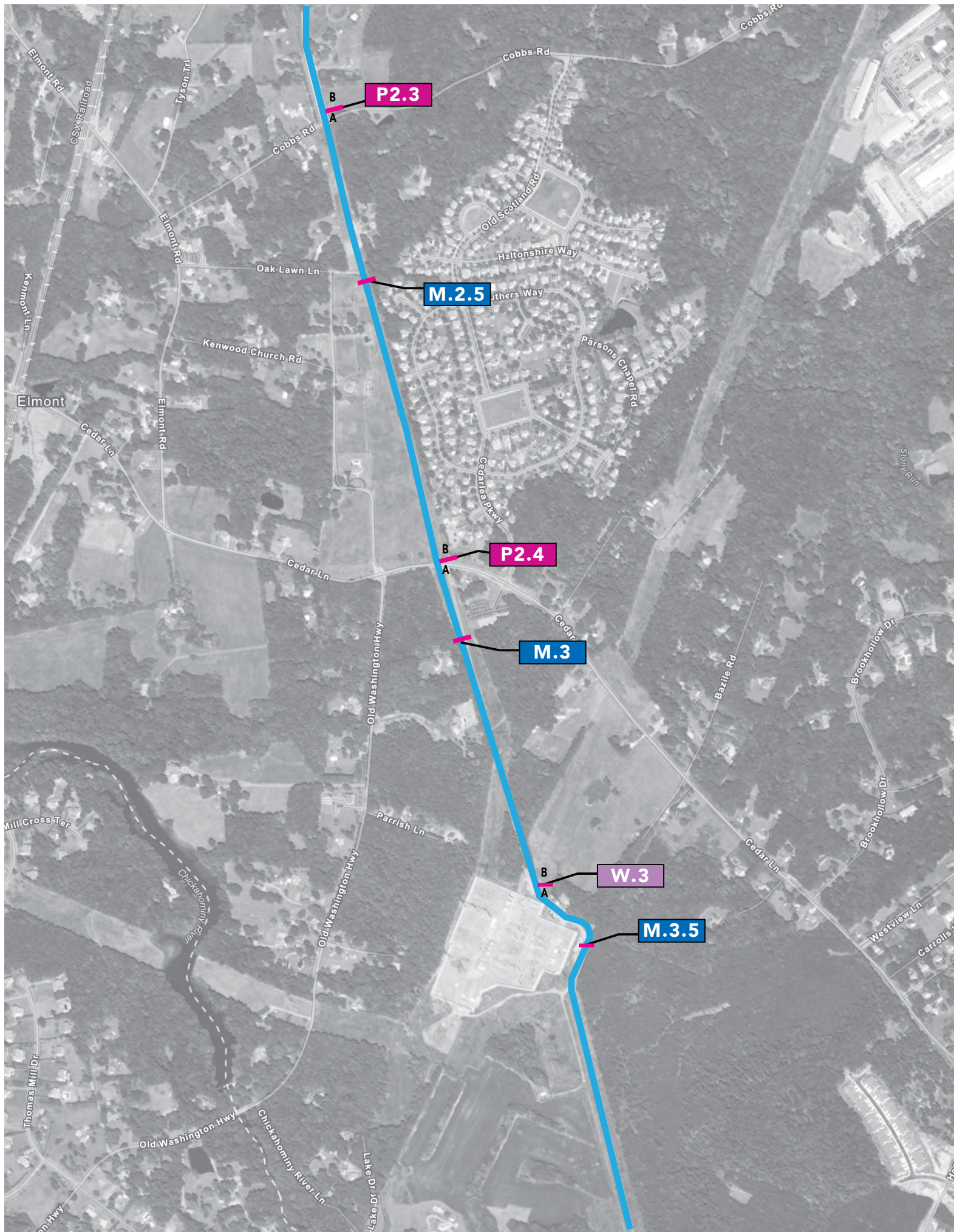





# PROGRAMMING Sign Location Plan Hanover

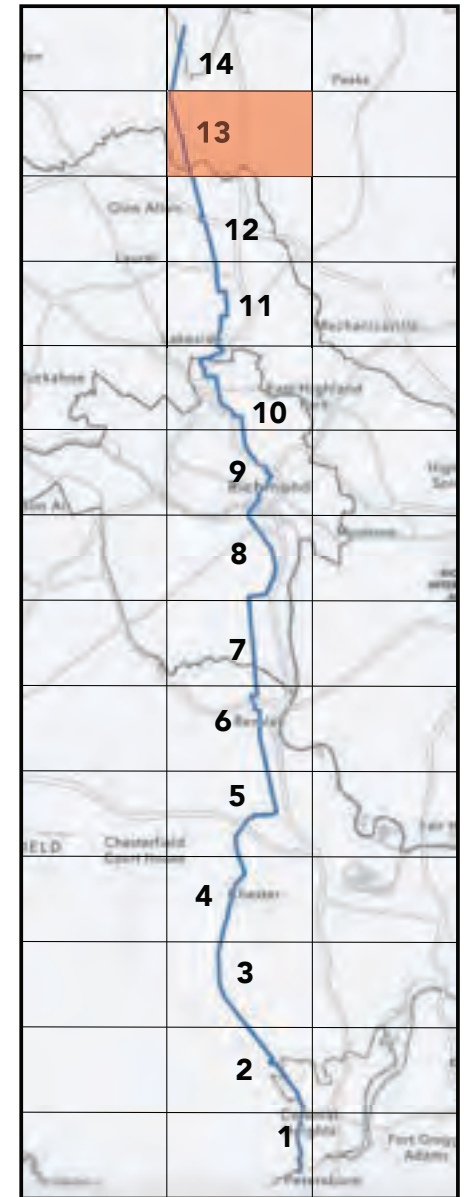

**SIGNTYPES KEY**

- ID Landmark Id.
- M Mile marker
- P Pedestrian Directional
- PL Plate
- T Trailhead Sign
- U Urban/ParkingMarker
- V Vehicular Directional
- W Directional
- Trail Access Point

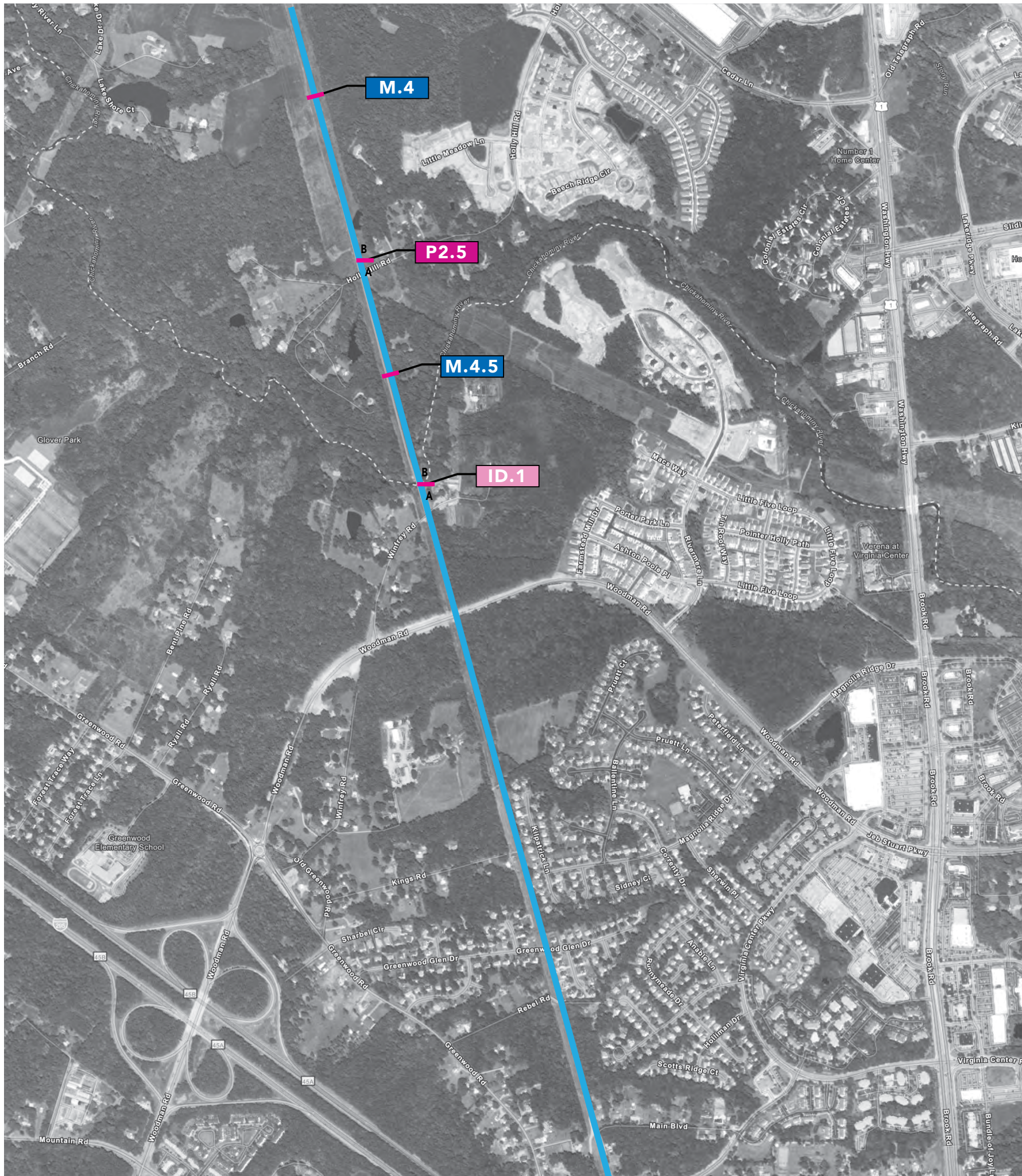

THIS DRAWING REPRESENTS DESIGN INTENT ONLY.

Date 7.31.23	Revisions 3.11.24 5.7.24 5.30.24	Scale NTS
-----------------	---	--------------

Client/Project  
CVTA, Virginia  
Wayfinding for Fall Line Trail

PROGRAMMING

Sign Types  
Hanover



Sign Type M.1  
Mile Marker

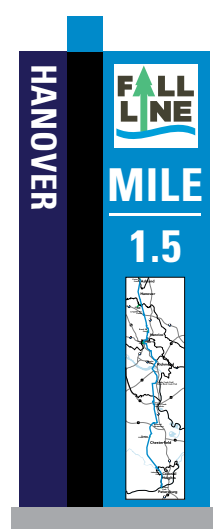

Sign Type M.1.5  
Mile Marker



Sign Type M.2  
Mile Marker

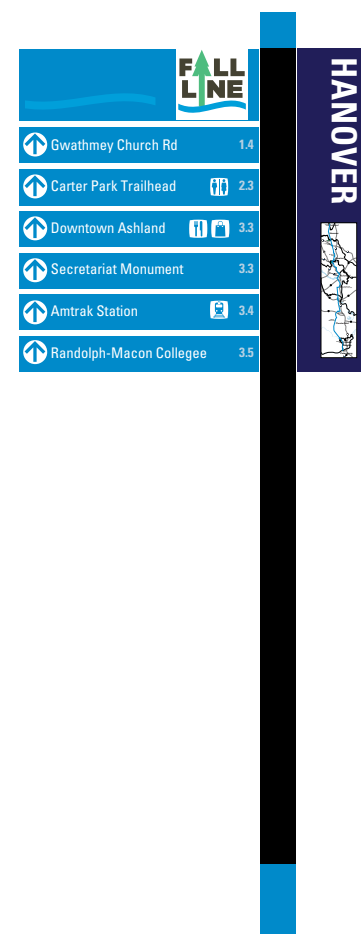

Sign Type P2.3A  
Pedestrian Directional

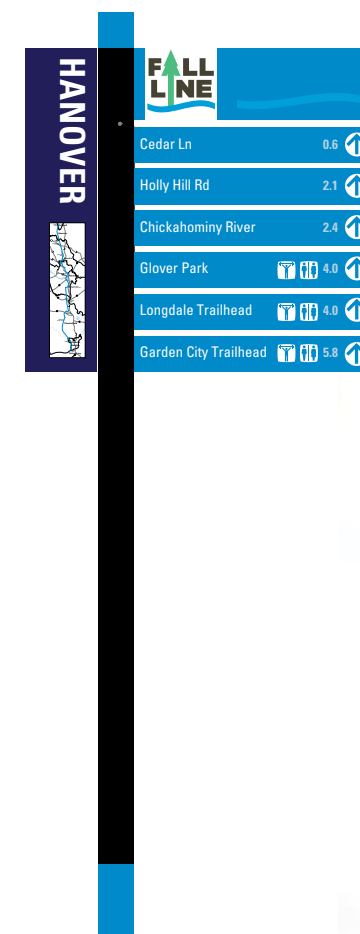

Sign Type P2.3B  
Pedestrian Directional



Sign Type M.2.5  
Mile Marker

THIS DRAWING REPRESENTS DESIGN INTENT ONLY.

Date	Revisions	Scale
1.10.24	3.11.24 5.7.24 5.30.24	3/4"=1'

Client/Project  
CVTA, Virginia  
Wayfinding for Fall Line Trail

© 2024 AB Design, Inc.

PROGRAMMING

Sign Types  
Hanover

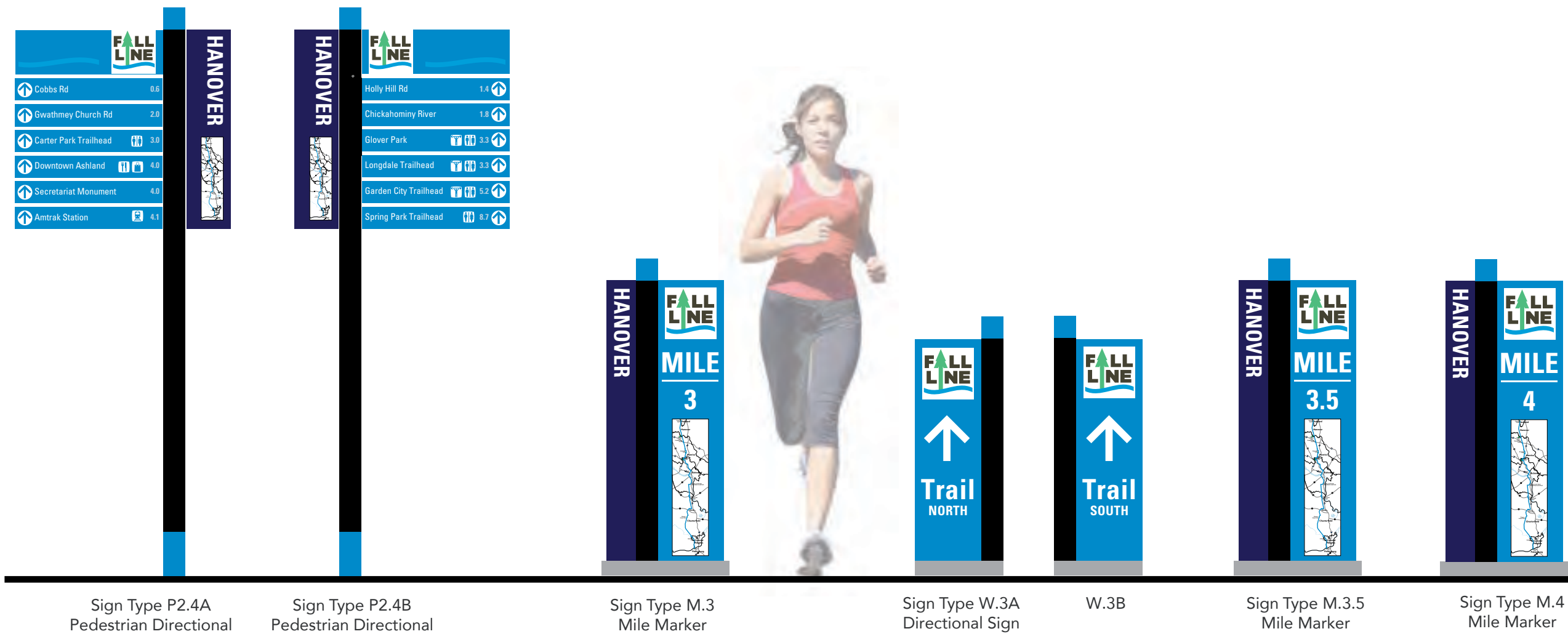

THIS DRAWING REPRESENTS DESIGN INTENT ONLY.

Date	Revisions	Scale
1.10.24	3.11.24	3/4"=1'
	5.7.24	
	5.30.24	

Client/Project  
CVTA, Virginia  
Wayfinding for Fall Line Trail

© 2024 AB Design, Inc.

PROGRAMMING

Sign Types  
Hanover

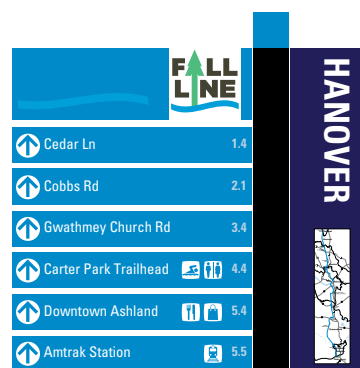

Sign Type P2.5A  
Pedestrian Directional



Sign Type P2.5B  
Pedestrian Directional



Sign Type M.4.5  
Mile Marker



Sign Type ID.1A  
Landmark Identification



Sign Type ID.1B  
Landmark Identification

THIS DRAWING REPRESENTS DESIGN INTENT ONLY.

Date	Revisions	Scale
1.10.24	3.11.24	3/4"=1'
	5.7.24	
	5.30.24	

Client/Project  
CVTA, Virginia  
Wayfinding for Fall Line Trail

© 2024 AB Design, Inc.

June 2024



# CVTA Wayfinding for Fall Line Trail

Programming  
Henrico County



1005 Stonemill Road  
Richmond, Virginia 23233  
Phone: 804-346-4771  
Fax: 804-325-1751  
[www.abdesignonline.com](http://www.abdesignonline.com)

June 2024



# CVTA Wayfinding for Fall Line Trail

Programming  
Henrico County



10005 Stonemill Road  
Richmond, Virginia 23233  
Phone: 804-346-4771  
Fax: 804-325-1751  
[www.abdesignonline.com](http://www.abdesignonline.com)



# PROGRAMMING

## Sign Location Plan

### Henrico

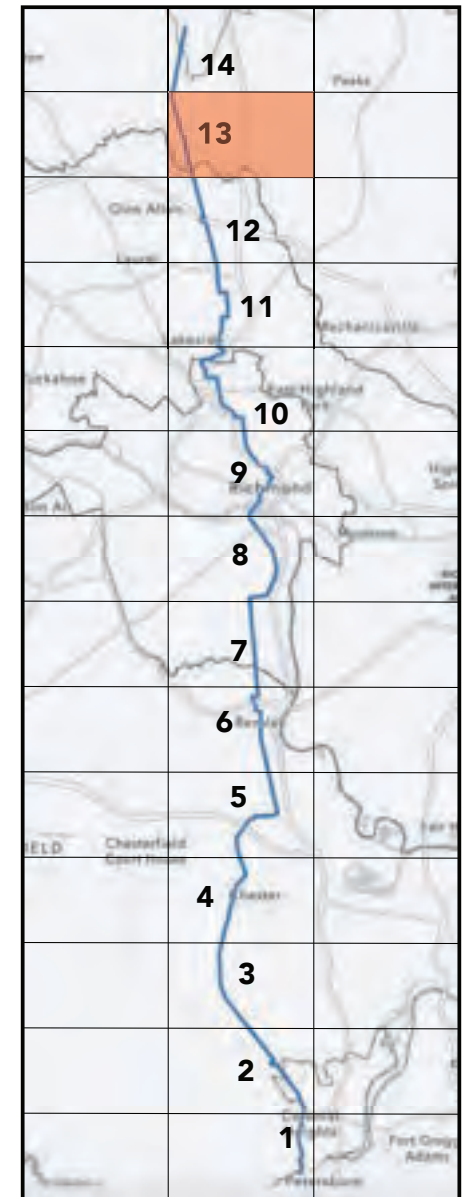

SIGNTYPES KEY	
<span style="background-color: #f08080; border: 1px solid black; padding: 2px;">ID</span>	Landmark Id.
<span style="background-color: #0070c0; border: 1px solid black; padding: 2px;">M</span>	Mile marker
<span style="background-color: #ff00ff; border: 1px solid black; padding: 2px;">P</span>	Pedestrian Directional
<span style="background-color: #ffa500; border: 1px solid black; padding: 2px;">PL</span>	Plate
<span style="background-color: #00ced1; border: 1px solid black; padding: 2px;">T</span>	Trailhead Sign
<span style="background-color: #90ee90; border: 1px solid black; padding: 2px;">U/P</span>	Urban/Parking Marker
<span style="background-color: #800080; border: 1px solid black; padding: 2px;">V</span>	Vehicular Directional
<span style="background-color: #800080; border: 1px solid black; padding: 2px;">W</span>	Directional
<span style="background-color: #32cd32; border: 1px solid black; border-radius: 50%; padding: 2px;">●</span>	Trail Access Point

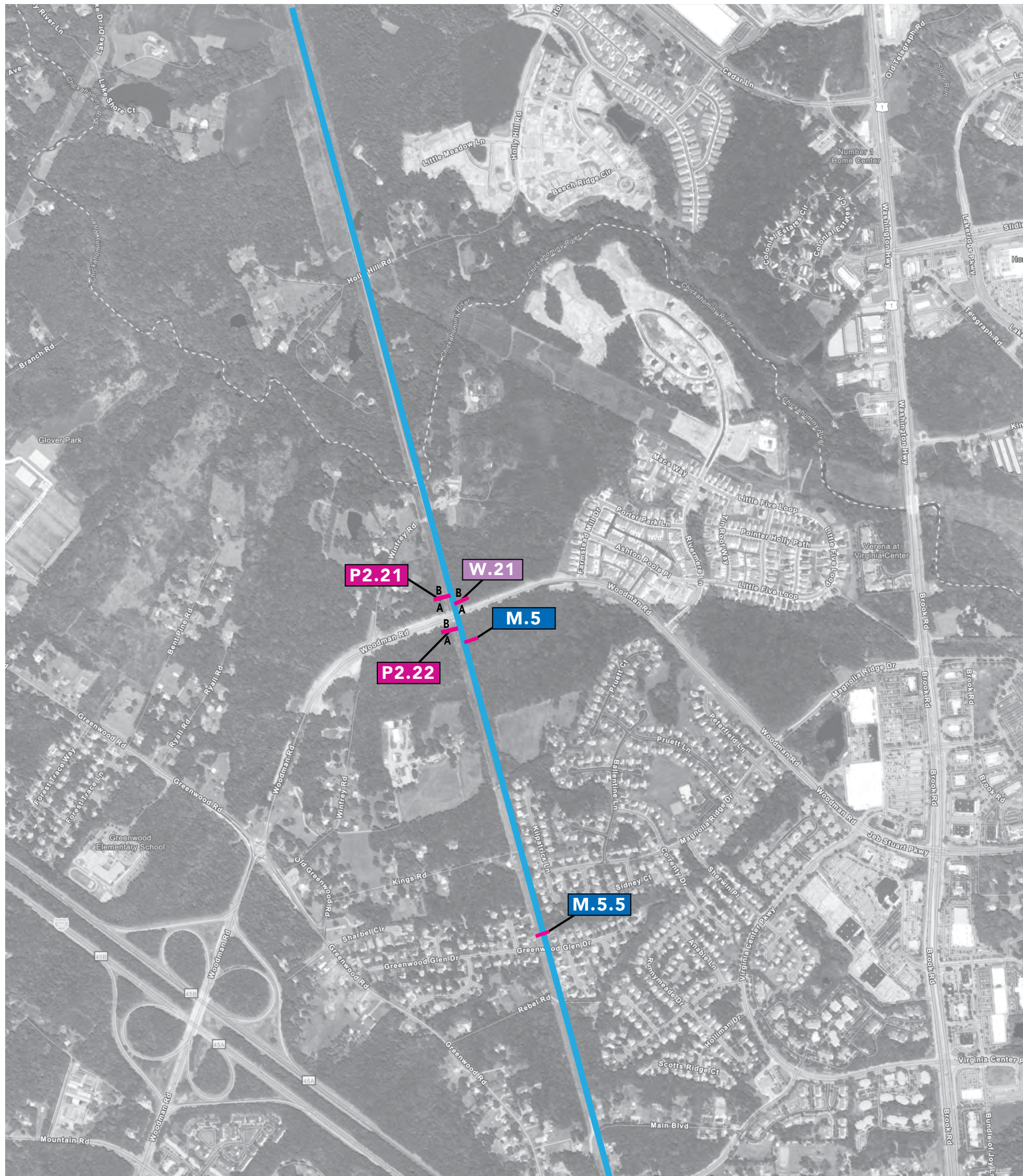

THIS DRAWING REPRESENTS DESIGN INTENT ONLY.

Date	Revisions	Scale
7.31.23	2.2.24	5.21.24
	2.26.24	NTS
	4.9.24	

Client/Project  
CVTA, Virginia  
Wayfinding for Fall Line Trail

© 2023 AB Design, Inc.

**HE.1**

**PROGRAMMING**  
Sign Location Plan  
Henrico



**SIGNTYPES KEY**

<span style="background-color: #f080f0; border: 1px solid black; padding: 2px;">ID</span>	Landmark Id.
<span style="background-color: #00b0f0; border: 1px solid black; padding: 2px;">M</span>	Mile marker
<span style="background-color: #ff00ff; border: 1px solid black; padding: 2px;">P</span>	Pedestrian Directional
<span style="background-color: #ffa500; border: 1px solid black; padding: 2px;">PL</span>	Plate
<span style="background-color: #00ced1; border: 1px solid black; padding: 2px;">T</span>	Trailhead Sign
<span style="background-color: #90ee90; border: 1px solid black; padding: 2px;">U/P</span>	Urban/Parking Marker
<span style="background-color: #800080; border: 1px solid black; padding: 2px;">V</span>	Vehicular Directional
<span style="background-color: #9370db; border: 1px solid black; padding: 2px;">W</span>	Directional
<span style="color: green;">●</span>	Trail Access Point

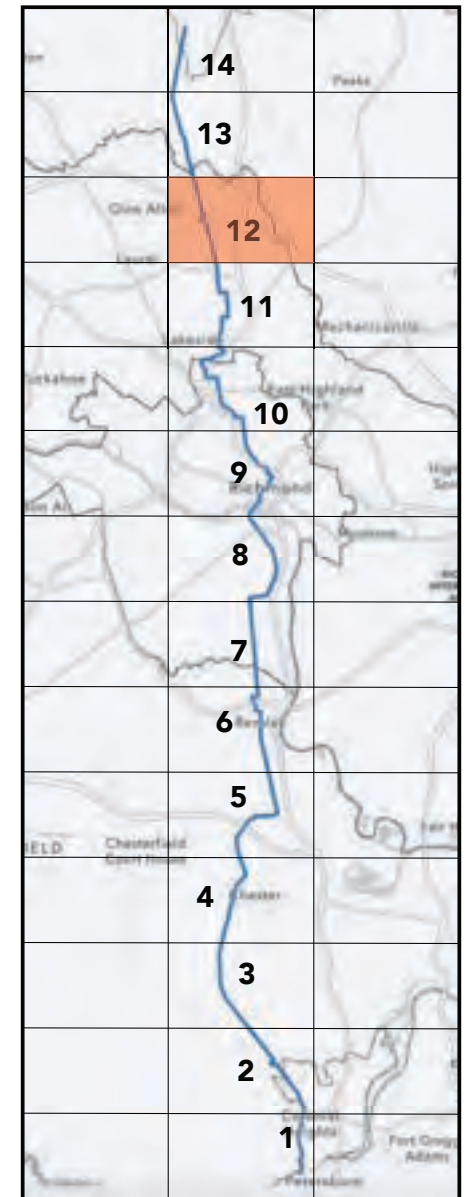

THIS DRAWING REPRESENTS DESIGN INTENT ONLY.

Date 7.31.23	Revisions 2.2.24 2.26.24 4.9.24	Scale NTS
-----------------	--	--------------

Client/Project  
CVTA, Virginia  
Wayfinding for Fall Line Trail





**PROGRAMMING**  
Sign Location Plan  
Henrico

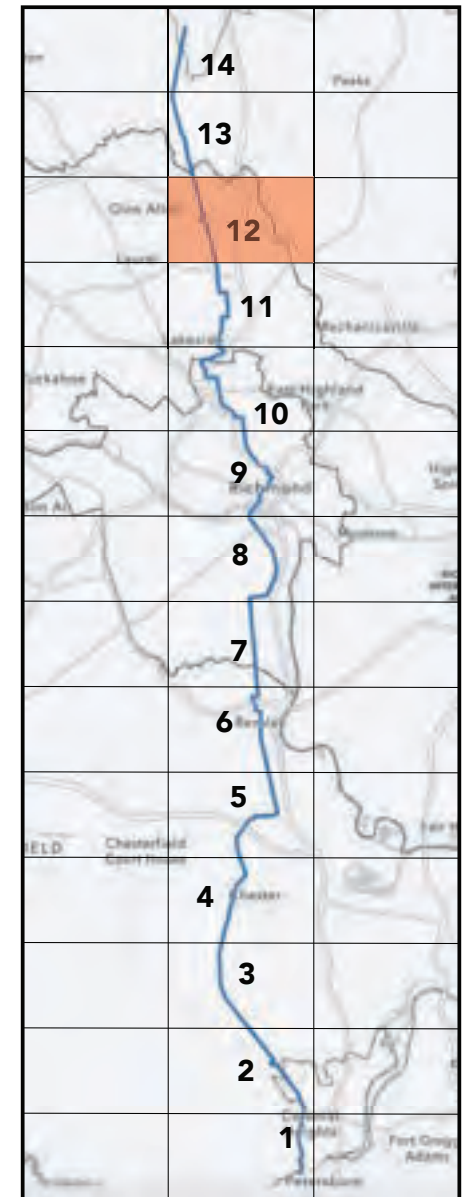

**SIGNTYPES KEY**

- ID Landmark Id.
- M Mile marker
- P Pedestrian Directional
- PL Plate
- T Trailhead Sign
- U/P Urban/Parking Marker
- V Vehicular Directional
- W Directional
- Trail Access Point

THIS DRAWING REPRESENTS DESIGN INTENT ONLY.

Date	Revisions	Scale
7.31.23	2.2.24 5.21.24	NTS
	2.26.24	
	4.9.24	

Client/Project  
CVTA, Virginia  
Wayfinding for Fall Line Trail

© 2023 AB Design, Inc.

**HE.3**

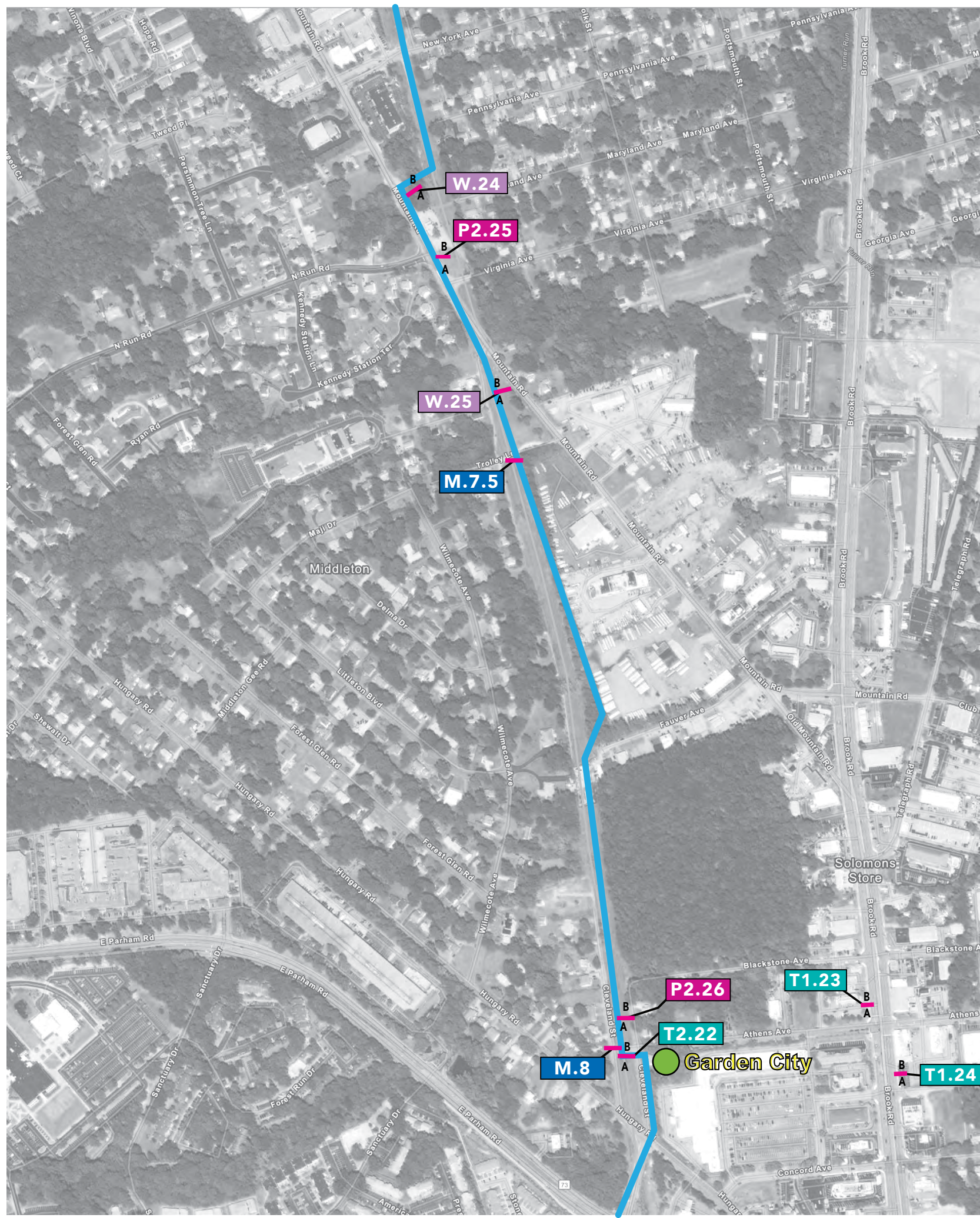

PROGRAMMING  
Sign Types  
Henrico

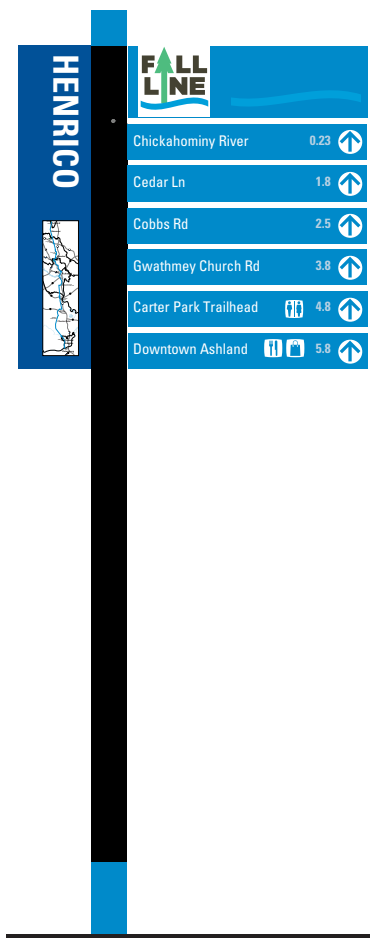
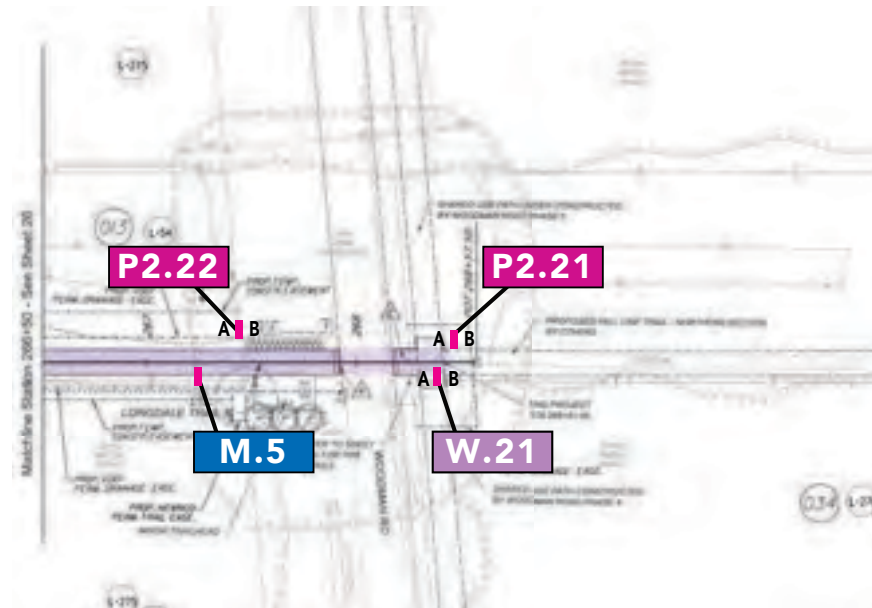

Sign Type P2.21A  
Pedestrian Directional

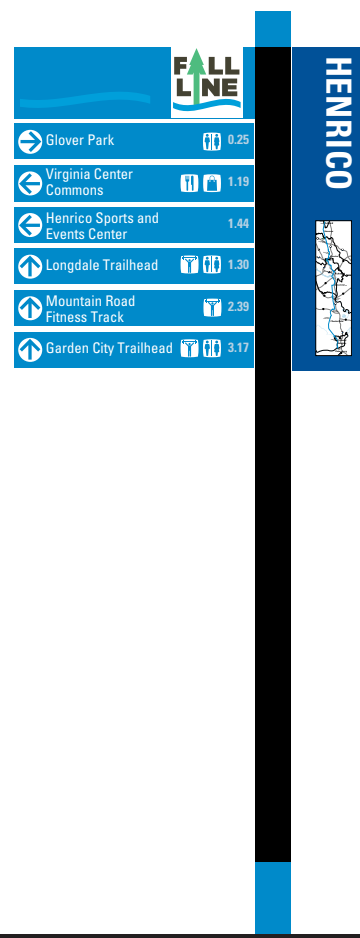

Sign Type P2.21B  
Pedestrian Directional



Sign Type W.21A  
Directional Sign

W.21B



Sign Type M.5  
Mile Marker

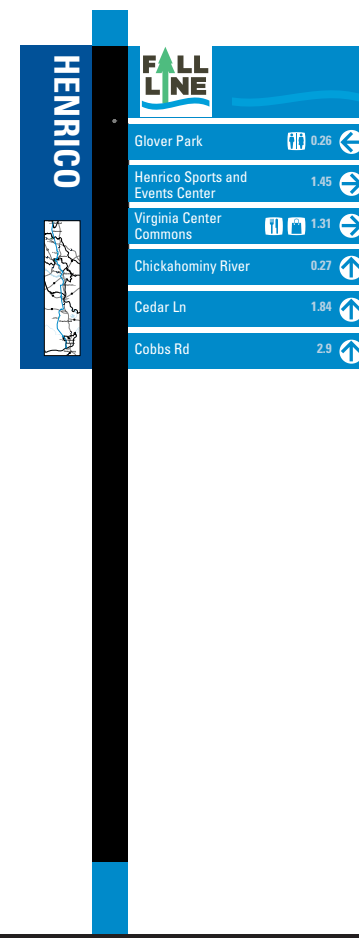

Sign Type P2.22A  
Pedestrian Directional

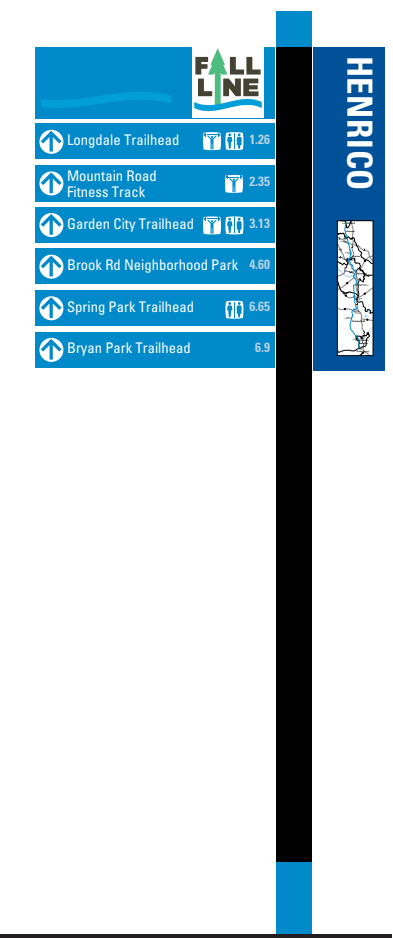

Sign Type P2.22B  
Pedestrian Directional

THIS DRAWING REPRESENTS DESIGN INTENT ONLY.

Date	Revisions	Scale
1.5.24	2.2.24 5.21.24	3/4"=1'
	2.26.24 5.28.24	
	4.9.24	

Client/Project  
CVTA, Virginia  
Wayfinding for Fall Line Trail

© 2024 AB Design, Inc.

PROGRAMMING  
Sign Types  
Henrico

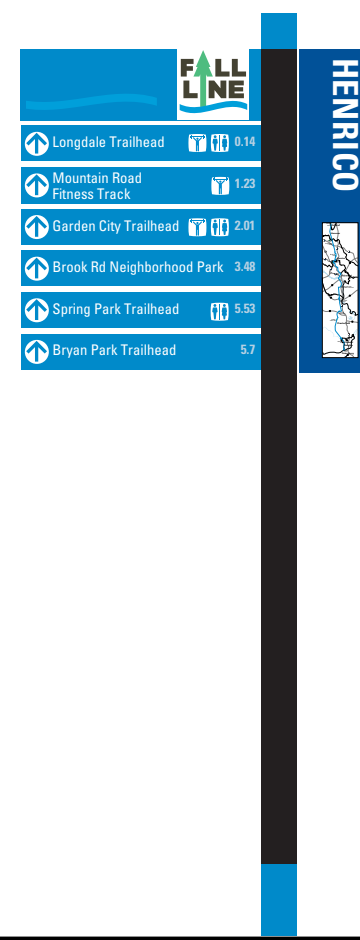
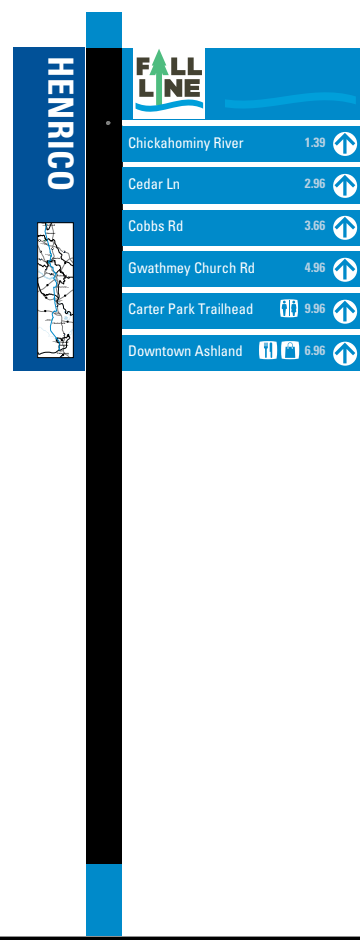
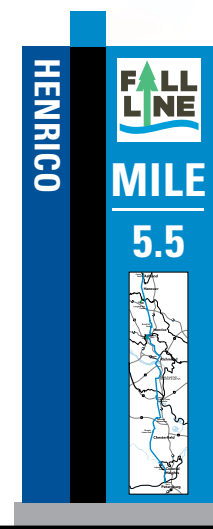
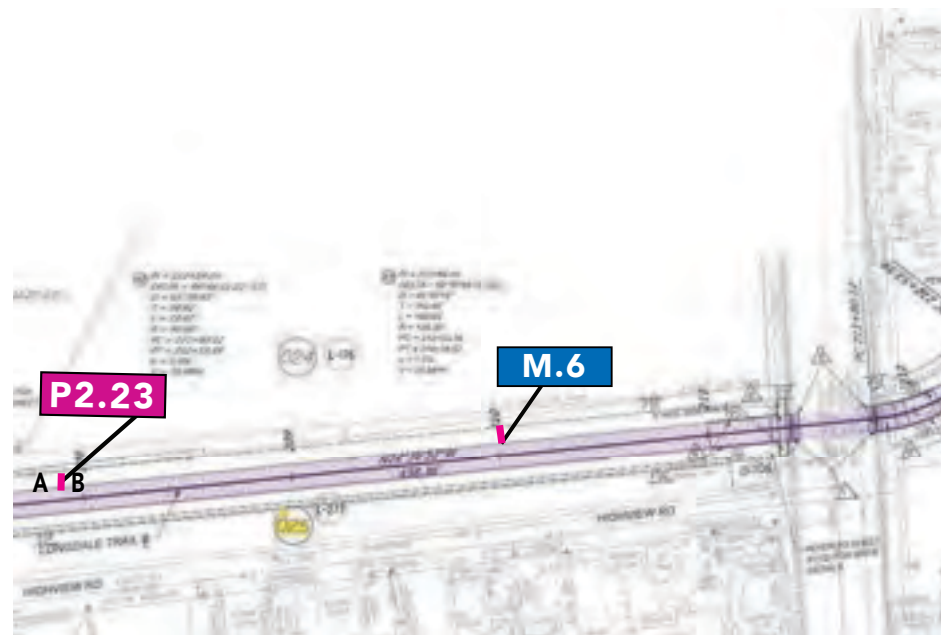
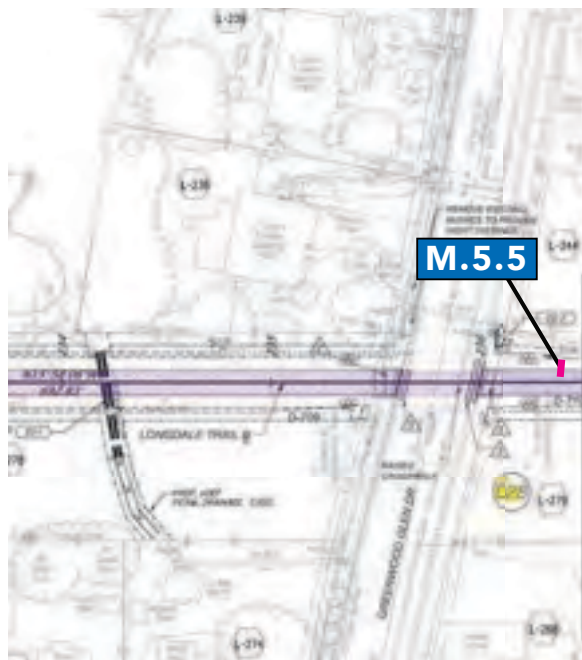

Sign Type M.5.5  
Mile Marker

Sign Type M.6  
Mile Marker

Sign Type P2.23A  
Pedestrian Directional

Sign Type P2.23B  
Pedestrian Directional

Sign Type T2.21A  
Pedestrian Trailhead/  
Regulatory Sign

Sign Type T2.21B  
Pedestrian Trailhead/  
Regulatory Sign

THIS DRAWING REPRESENTS DESIGN INTENT ONLY.

Date	Revisions	Scale
1.5.24	2.2.24 2.26.24 4.9.24	5.21.24 5.28.24 3/4"=1'

Client/Project  
CVTA, Virginia  
Wayfinding for Fall Line Trail

© 2024 AB Design, Inc.

PROGRAMMING

Sign Types  
Henrico

THIS DRAWING REPRESENTS DESIGN INTENT ONLY.

Date	Revisions	Scale
1.5.24	2.2.24 2.26.24 4.9.24	3/4"=1'

Client/Project  
CVTA, Virginia  
Wayfinding for Fall Line Trail

© 2024 AB Design, Inc.

**HE.6**

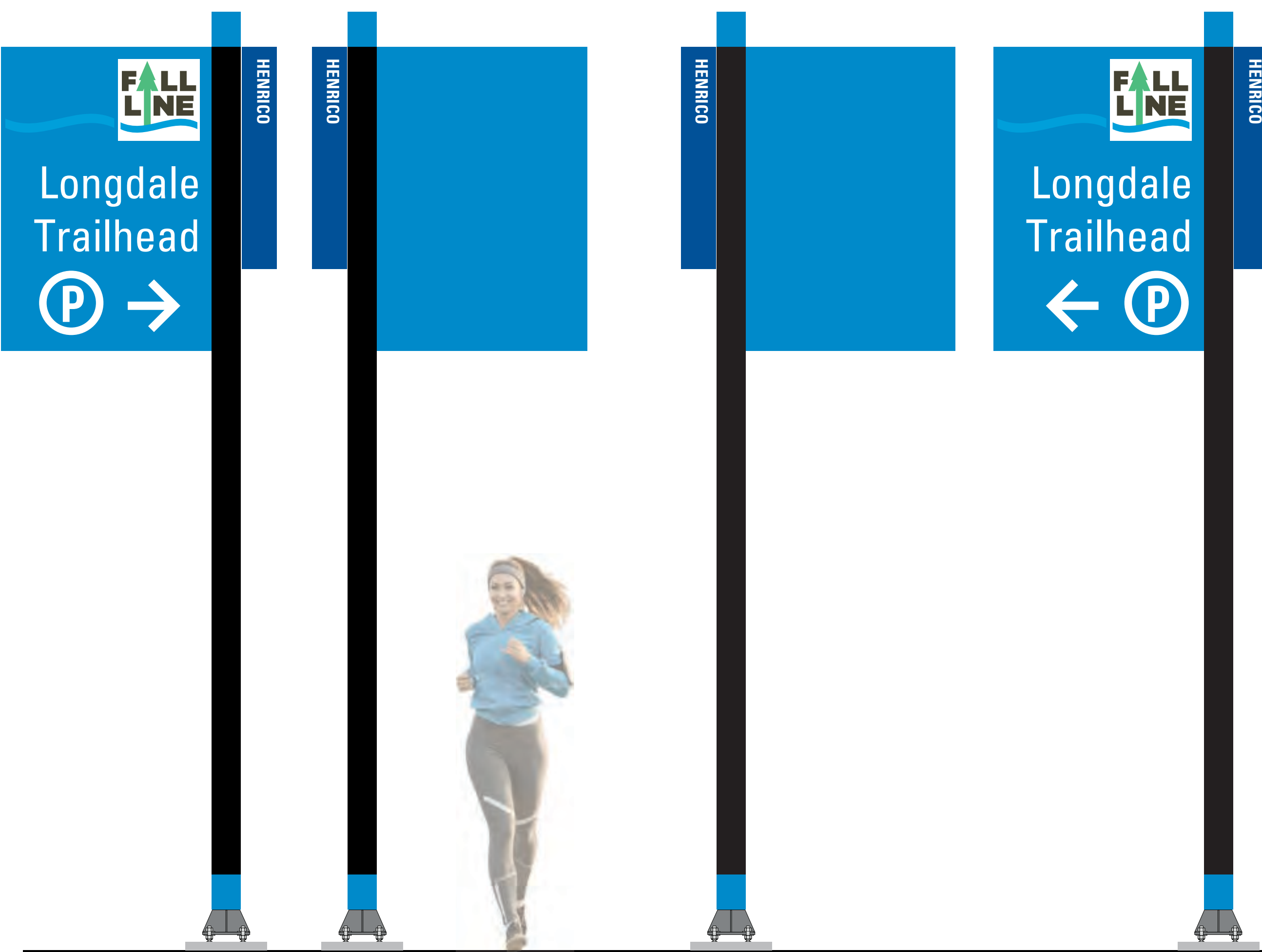

Sign Type T1.21A  
Vehicular  
Trailhead Sign

Sign Type T1.21B  
Vehicular  
Trailhead Sign

Sign Type T1.22A  
Vehicular  
Trailhead Sign

Sign Type T1.22B  
Vehicular  
Trailhead Sign

PROGRAMMING  
Sign Types  
Henrico

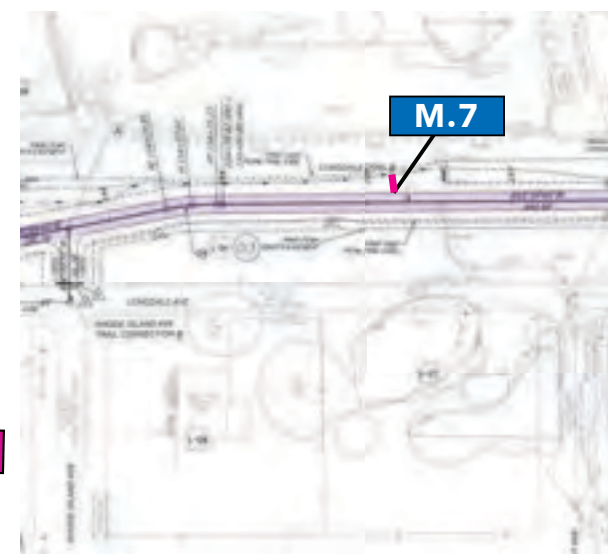
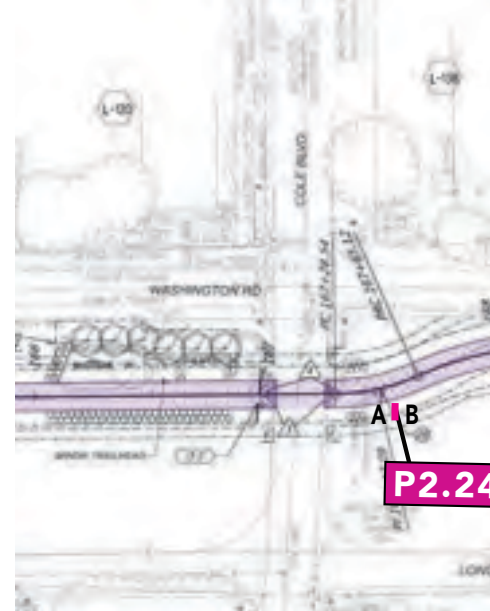
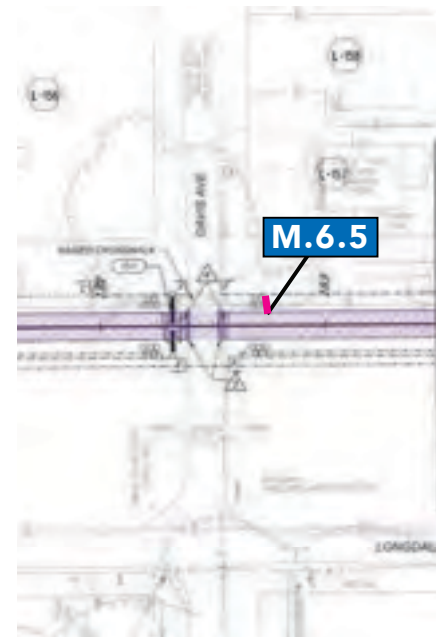
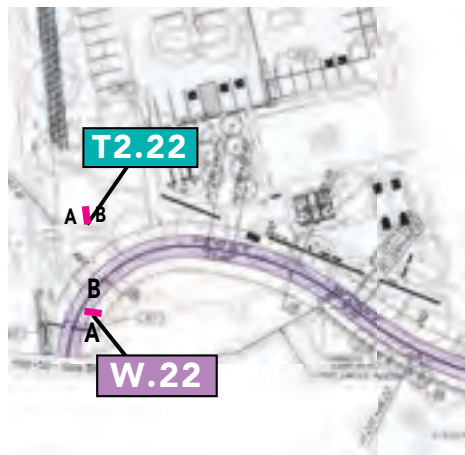

Sign Type W.22A Directional Sign    W.22B    Sign Type W.23A Directional Sign    W.23B    Sign Type M.6.5 Mile Marker    Sign Type P2.24A Pedestrian Directional    Sign Type P2.24B Pedestrian Directional    Sign Type M.7 Mile Marker



THIS DRAWING REPRESENTS DESIGN INTENT ONLY.

Date	Revisions	Scale
1.5.24	2.2.24    5.21.24 2.26.24    5.28.24 4.9.24	3/4" = 1'

Client/Project  
CVTA, Virginia  
Wayfinding for Fall Line Trail

© 2024 AB Design, Inc.

PROGRAMMING  
Sign Types  
Henrico

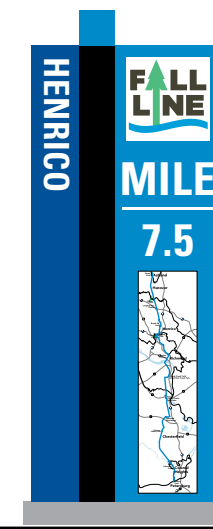
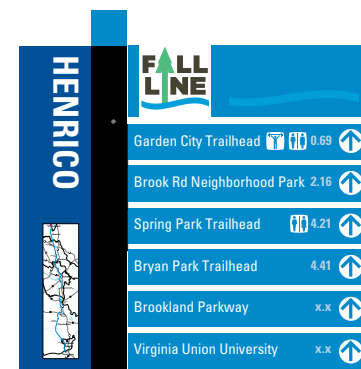
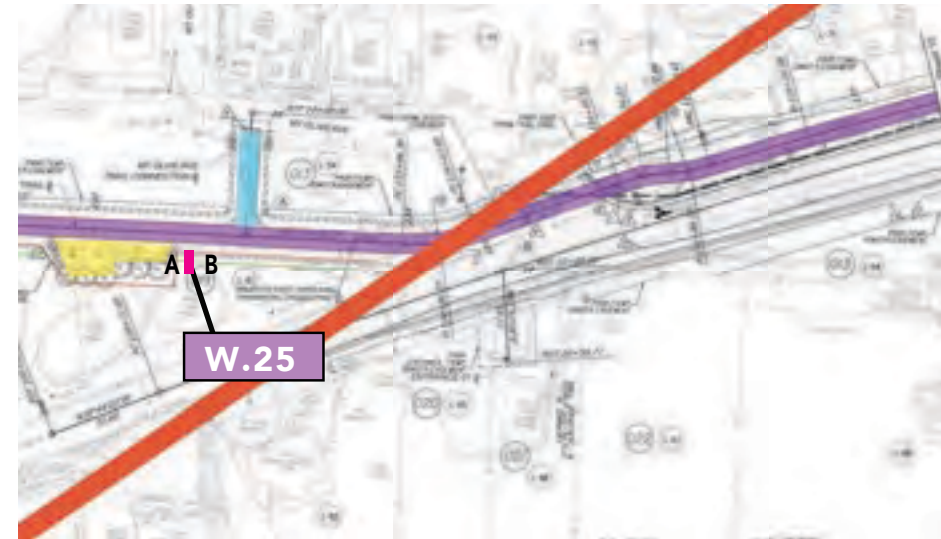
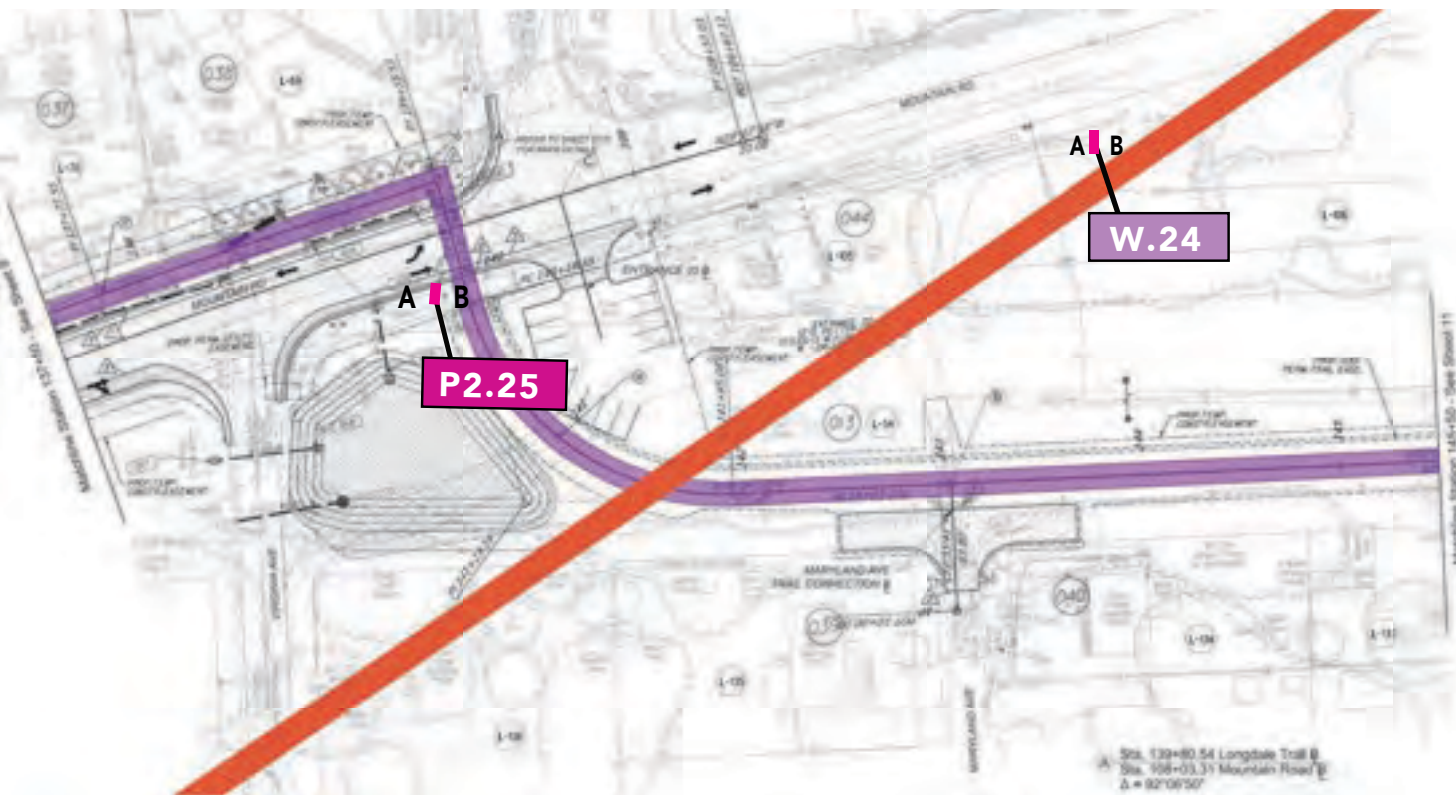

Sign Type W.24A  
Directional Sign

W.24B

Sign Type P2.25A  
Pedestrian Directional

Sign Type P2.25B  
Pedestrian Directional

Sign Type W.25A  
Directional Sign

W.25B

Sign Type M.7.5  
Mile Marker

THIS DRAWING REPRESENTS DESIGN INTENT ONLY.

Date	Revisions	Scale
1.5.24	2.2.24 5.21.24	3/4" = 1'
	2.26.24 4.9.24	

Client/Project  
CVTA, Virginia  
Wayfinding for Fall Line Trail

© 2024 AB Design, Inc.

PROGRAMMING  
Sign Types  
Henrico

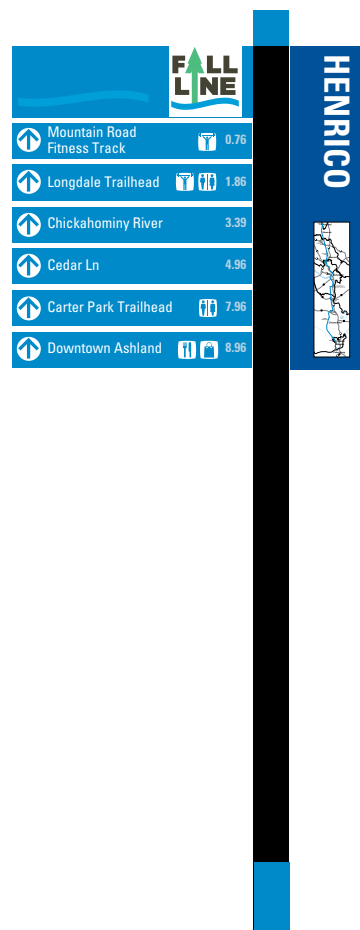
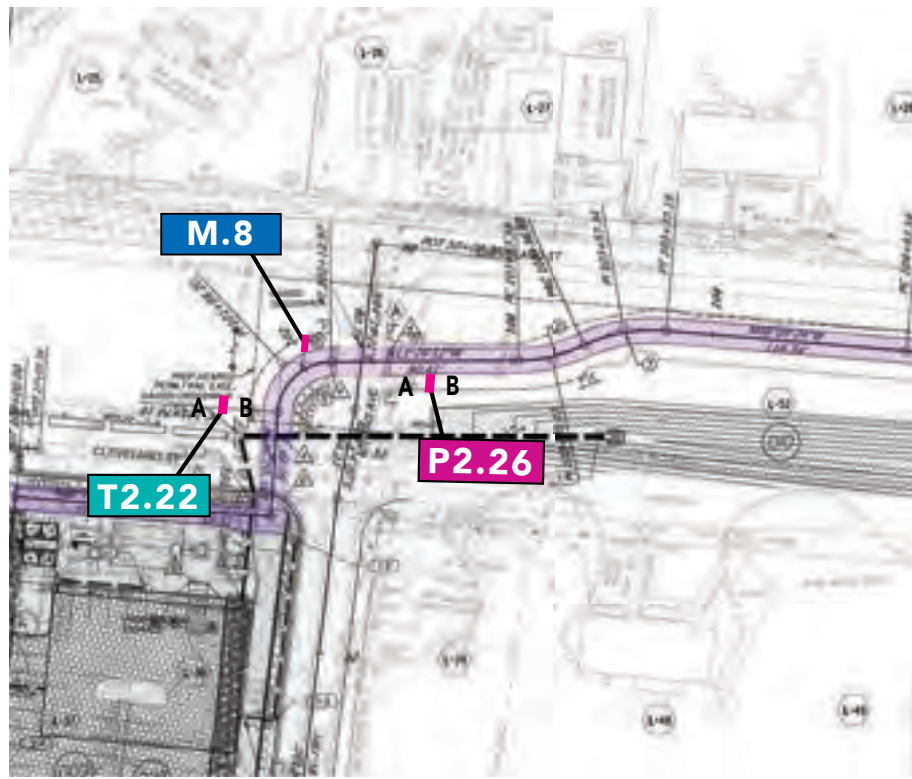

Sign Type P2.26A  
Pedestrian Directional

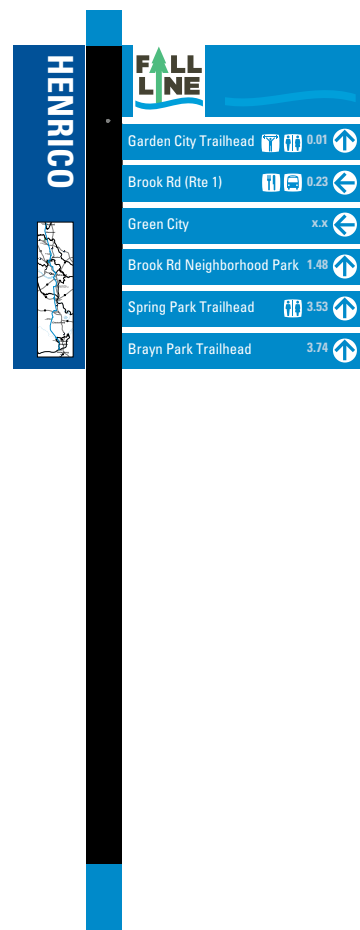

Sign Type P2.26B  
Pedestrian Directional

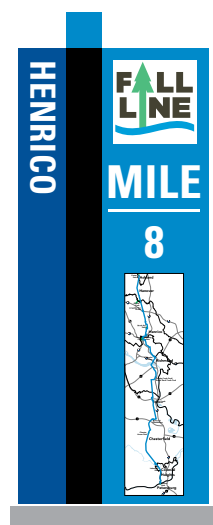

Sign Type M.8  
Mile Marker



Sign Type T2.22A  
Pedestrian Trailhead/  
Regulatory Sign



Sign Type T2.22B  
Pedestrian Trailhead/  
Regulatory Sign

THIS DRAWING REPRESENTS DESIGN INTENT ONLY.

Date	Revisions	Scale
1.5.24	2.2.24 5.21.24 2.26.24 5.28.24 4.9.24	3/4" = 1'

Client/Project  
CVTA, Virginia  
Wayfinding for Fall Line Trail

© 2024 AB Design, Inc.



Sign Type T1.23A  
Vehicular  
Trailhead Sign



Sign Type T1.23B  
Vehicular  
Trailhead Sign



Sign Type T1.24A  
Vehicular  
Trailhead Sign



Sign Type T1.24B  
Vehicular  
Trailhead Sign

PROGRAMMING  
Sign Types  
Henrico

THIS DRAWING REPRESENTS DESIGN INTENT ONLY.

Date 4.11.24	Revisions 5.21.24	Scale 3/4" = 1'
-----------------	----------------------	--------------------

Client/Project  
CVTA, Virginia  
Wayfinding for Fall Line Trail

© 2024 AB Design, Inc.

**HE.10**



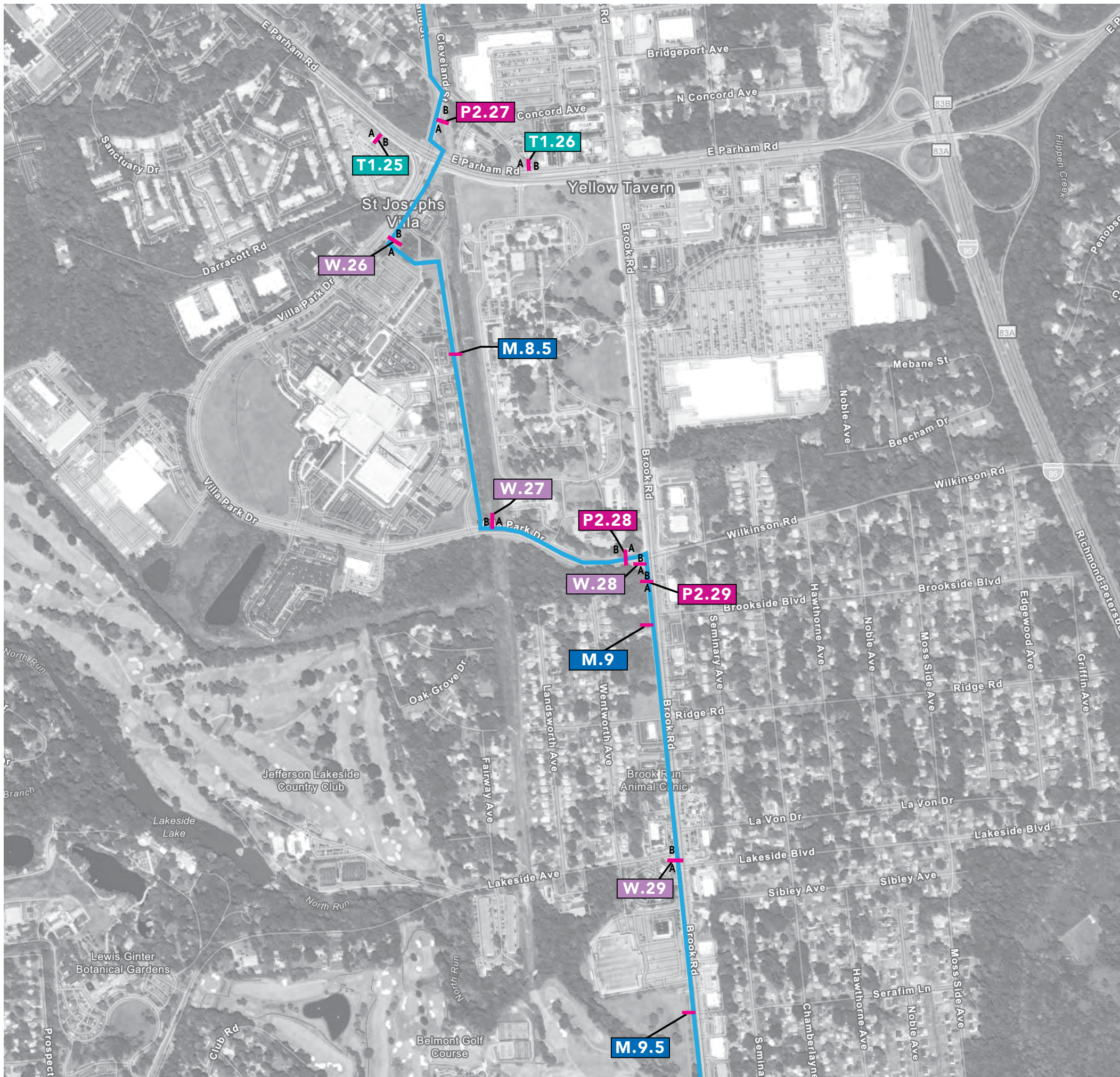

**SIGNTYPES KEY**

- ID Landmark Id.
- M Mile marker
- P Pedestrian Directional
- PL Plate
- T Trailhead Sign
- U/P Urban/Parking Marker
- V Vehicular Directional
- W Directional
- Trail Access Point

**PROGRAMMING**  
 Sign Location Plan  
 Henrico

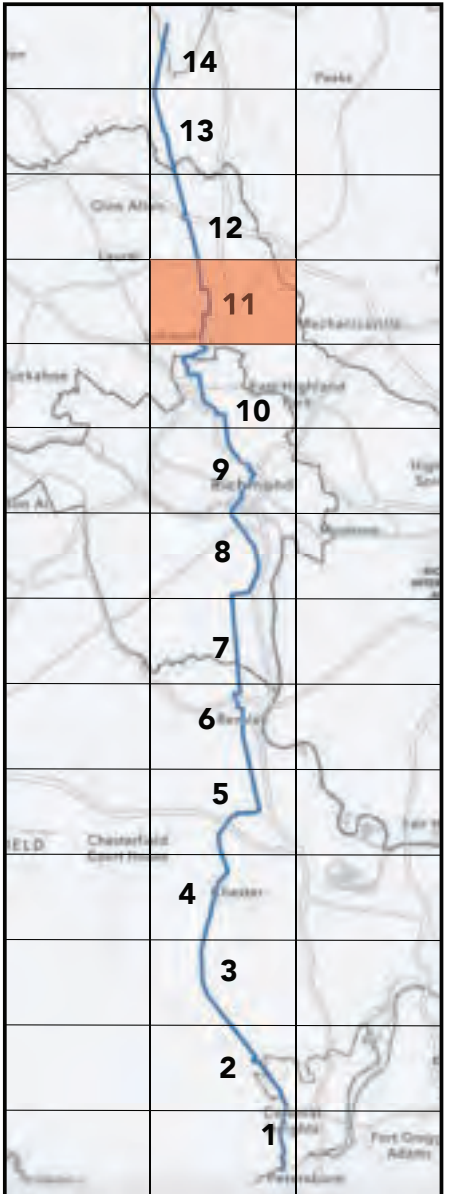

THIS DRAWING REPRESENTS DESIGN INTENT ONLY.

Date	Revisions	Scale
1.5.24	2.2.24 2.26.24 4.9.24	5.21.24 NTS

Client/Project  
 CVTA, Virginia  
 Wayfinding for Fall Line Trail

© 2024 AB Design, Inc.

**HE.11**

PROGRAMMING  
Sign Types  
Henrico

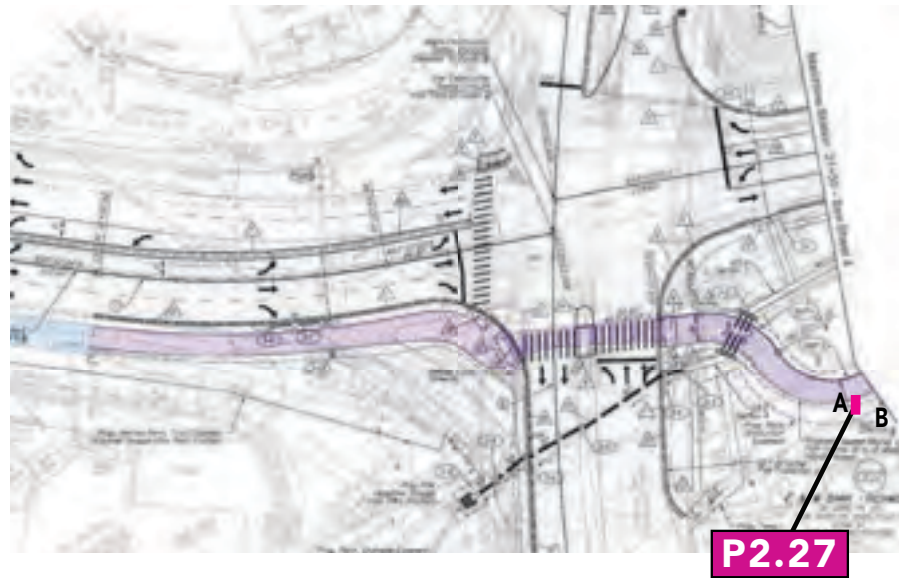

Sign Type P2.27A  
Pedestrian Directional

Sign Type P2.27B  
Pedestrian Directional

THIS DRAWING REPRESENTS DESIGN INTENT ONLY.

Date	Revisions	Scale
1.5.24	2.2.24 5.21.24	3/4"=1'
	2.26.24 5.28.24	
	4.9.24	

Client/Project  
CVTA, Virginia  
Wayfinding for Fall Line Trail

© 2024 AB Design, Inc.



PROGRAMMING

Sign Types  
Henrico

THIS DRAWING REPRESENTS DESIGN INTENT ONLY.

Date 4.11.24	Revisions 5.21.24	Scale 3/4"=1'
-----------------	----------------------	------------------

Client/Project  
CVTA, Virginia  
Wayfinding for Fall Line Trail

© 2024 AB Design, Inc.

**HE.13**



Sign Type T1.25A  
Vehicular  
Trailhead Sign



Sign Type T1.25B  
Vehicular  
Trailhead Sign



Sign Type T1.26A  
Vehicular  
Trailhead Sign



Sign Type T1.26B  
Vehicular  
Trailhead Sign

PROGRAMMING  
Sign Types  
Henrico

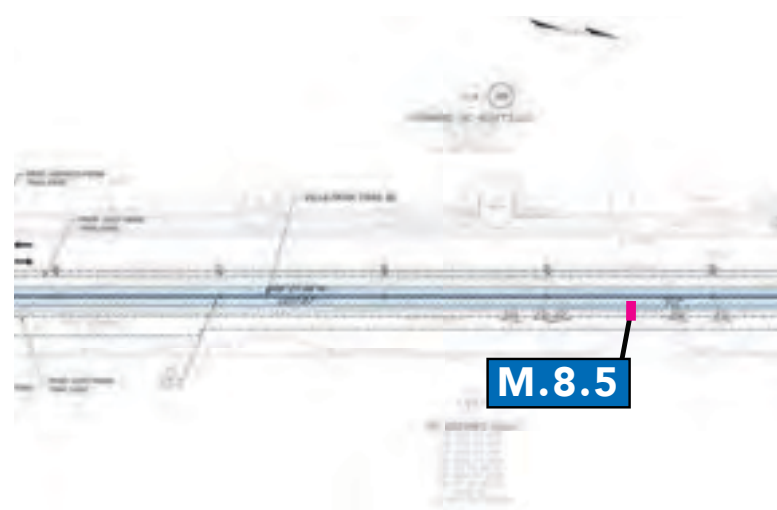
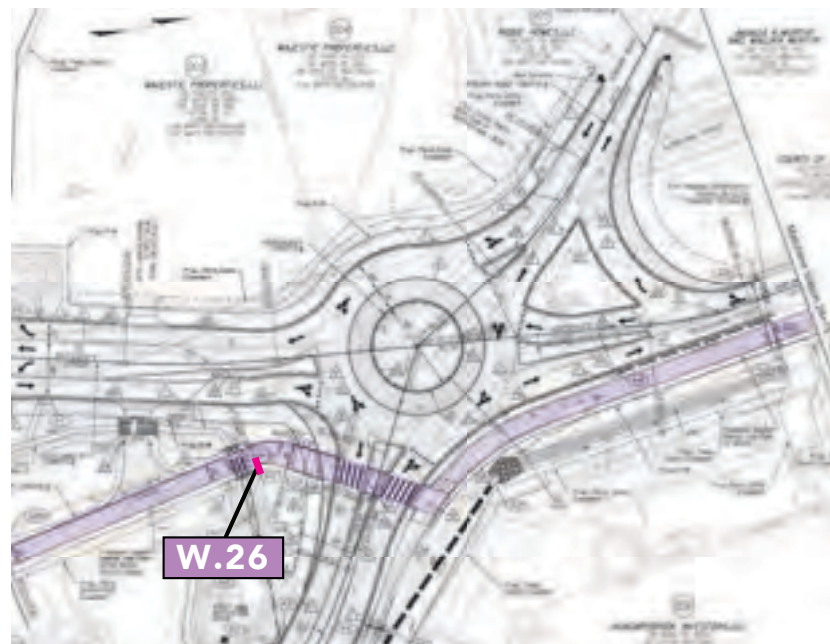

Sign Type W.26A  
Directional Sign



W.26B

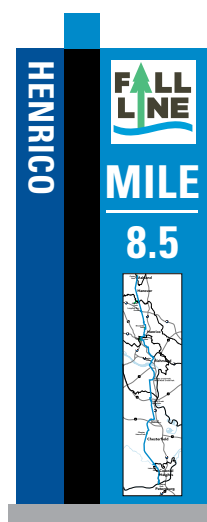

Sign Type M.8.5  
Mile Marker



Sign Type W.279A  
Directional Sign



W.27B

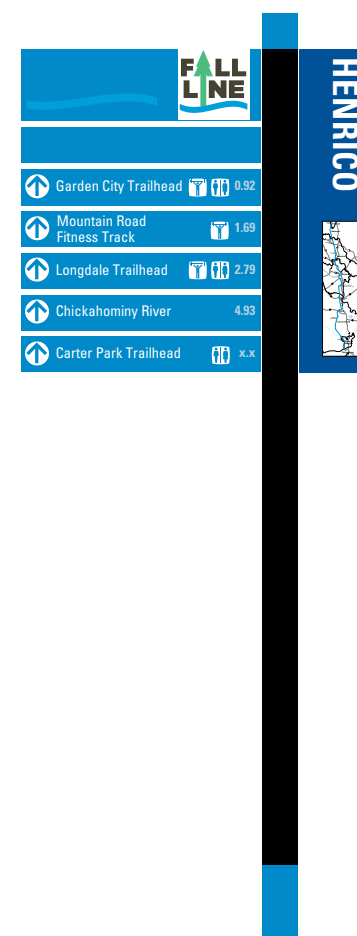

Sign Type P2.28A  
Pedestrian Directional

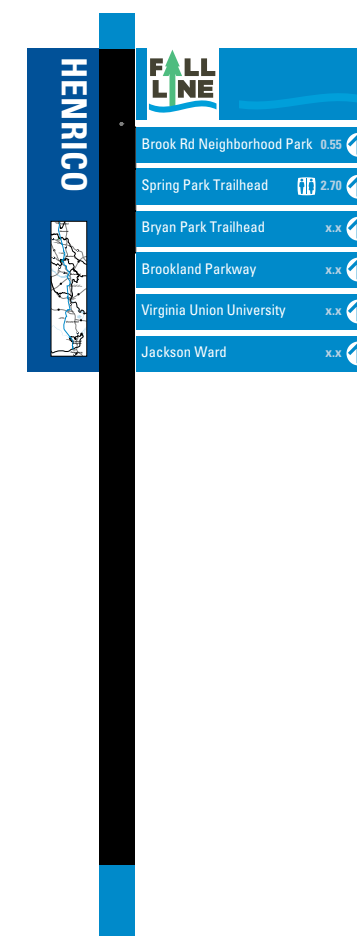

Sign Type P2.28B  
Pedestrian Directional

THIS DRAWING REPRESENTS DESIGN INTENT ONLY.

Date	Revisions	Scale
1.5.24	2.2.24 2.26.24 4.9.24	5.21.24 5.28.24 3/4"=1'

Client/Project  
CVTA, Virginia  
Wayfinding for Fall Line Trail

© 2024 AB Design, Inc.

PROGRAMMING  
Sign Types  
Henrico

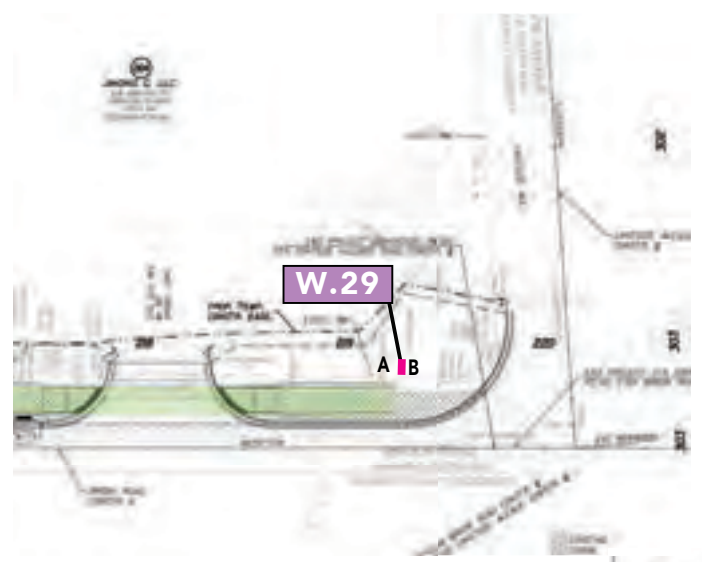
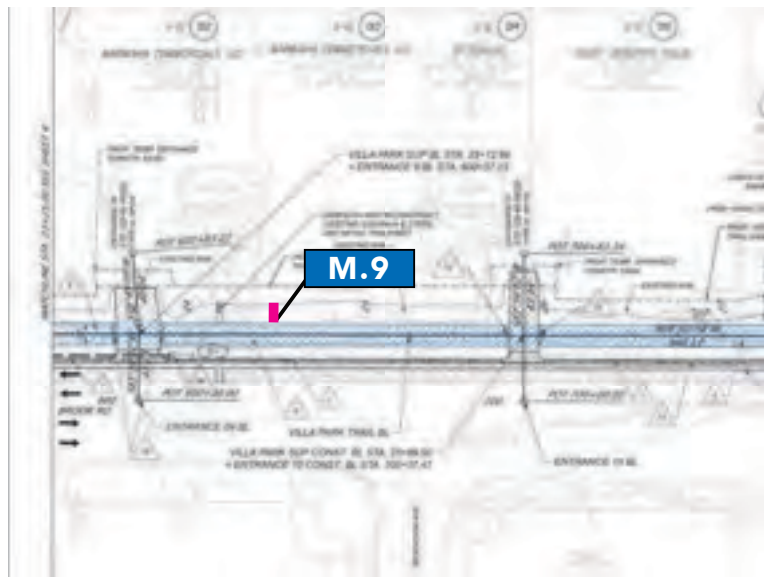

Sign Type W.28A  
Directional Sign



W.28B

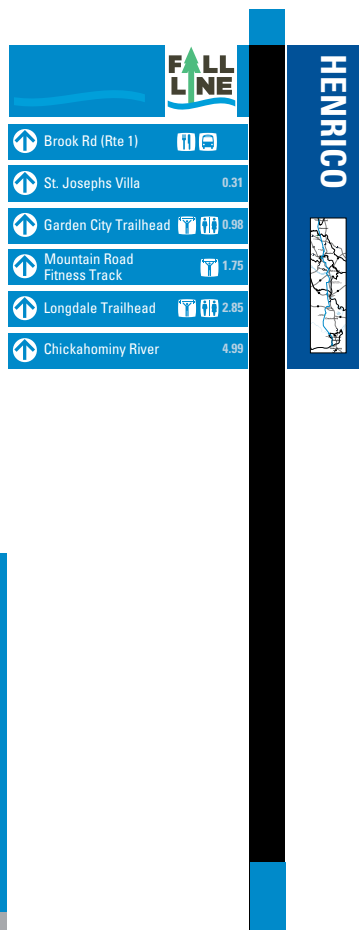

Sign Type P2.29A  
Pedestrian Directional

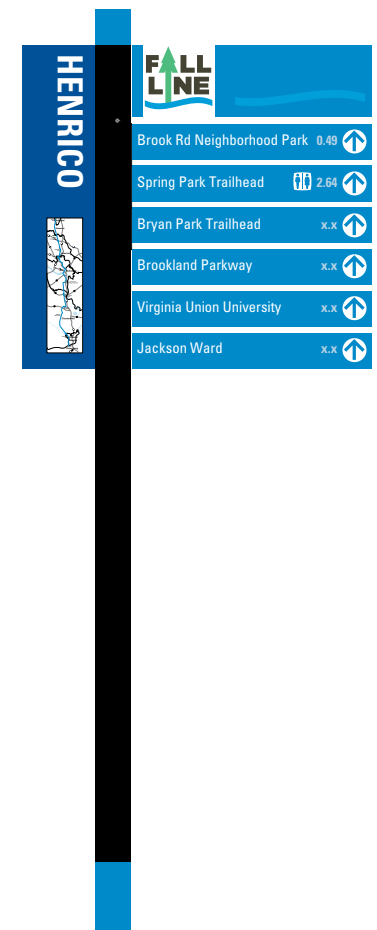

Sign Type P2.29B  
Pedestrian Directional

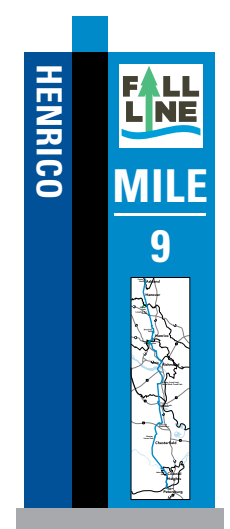

Sign Type M.9  
Mile Marker



Sign Types W.29A  
Directional Sign



W.29B

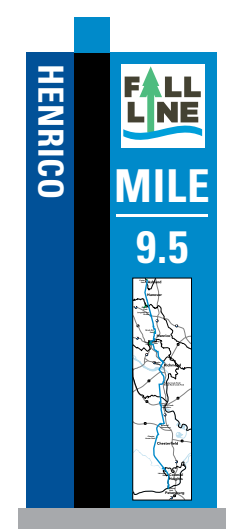

Sign Type M.9.5  
Mile Marker

THIS DRAWING REPRESENTS DESIGN INTENT ONLY.

Date	Revisions	Scale
1.5.24	2.2.24 2.26.24 4.9.24	5.21.24 5.28.24 3/4"=1'

Client/Project  
CVTA, Virginia  
Wayfinding for Fall Line Trail

© 2024 AB Design, Inc.



**PROGRAMMING**  
Sign Location Plan  
Henrico

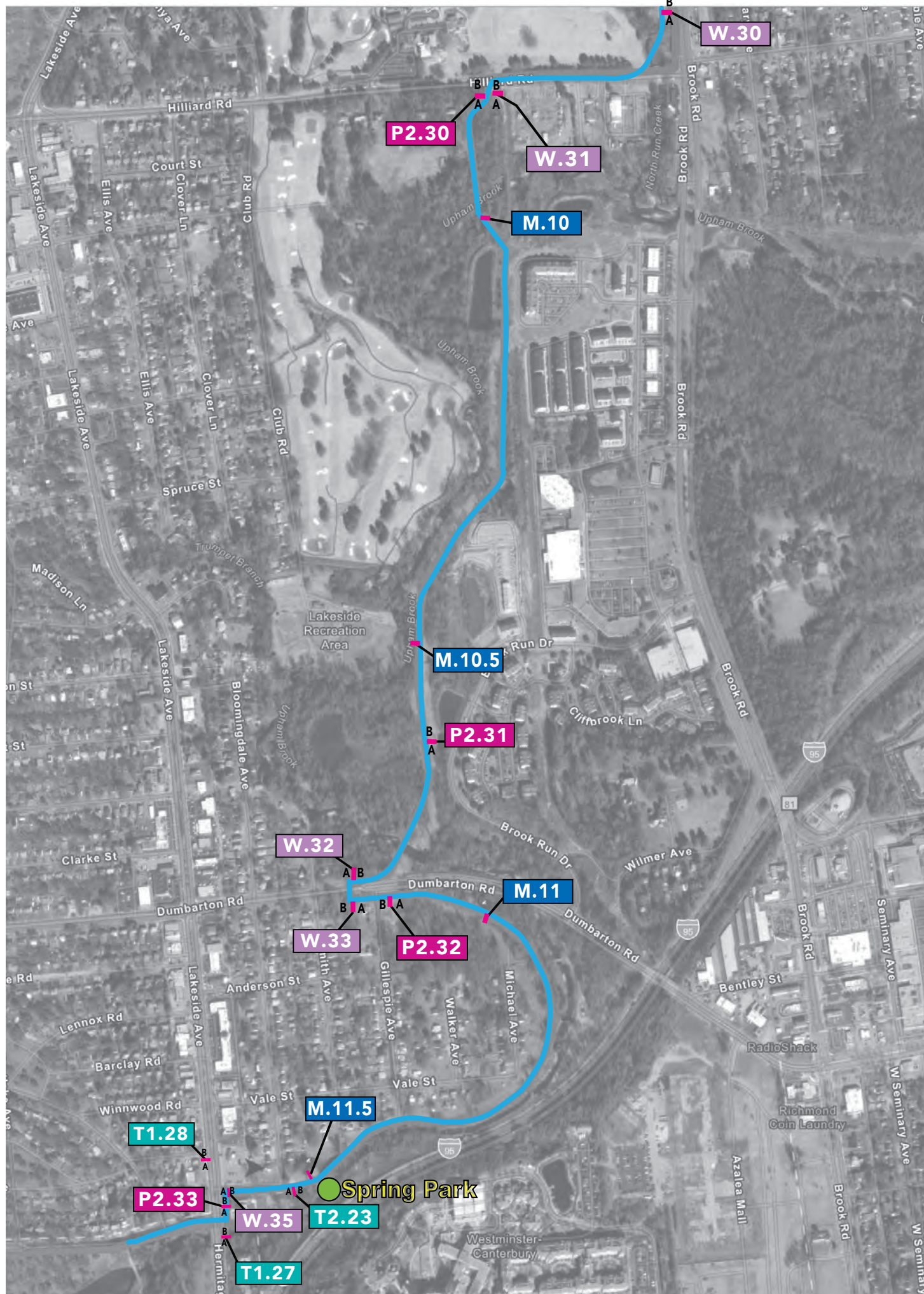

**SIGNTYPES KEY**

ID	Landmark Id.
M	Mile marker
P	Pedestrian Directional
PL	Plate
T	Trailhead Sign
U	Urban/ParkingMarker
V	Vehicular Directional
W	Directional
●	Trail Access Point

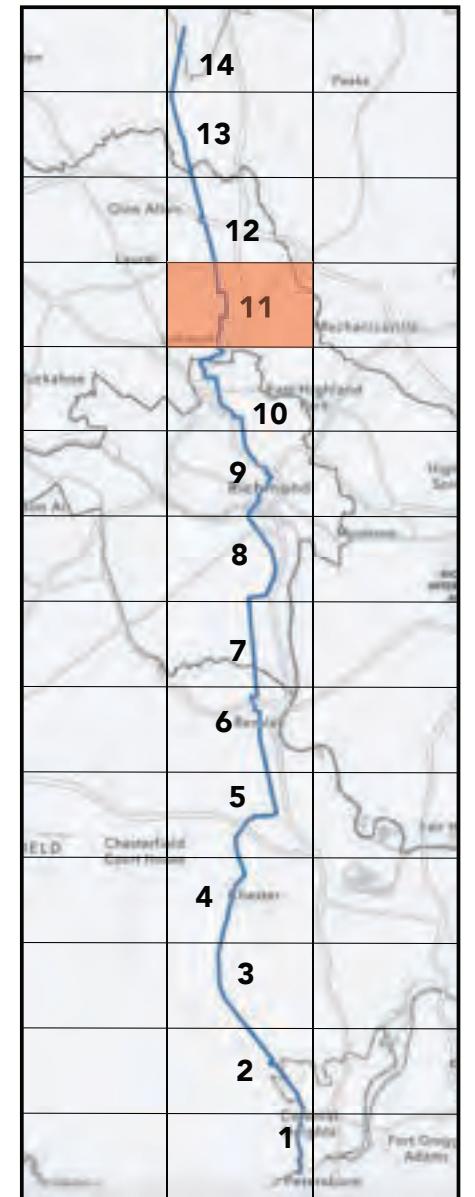

THIS DRAWING REPRESENTS DESIGN INTENT ONLY.

Date	Revisions	Scale
10.27.23	11.6.23 2.26.24 12.4.23 4.11.24 2.2.24 5.21.24	NTS

Client/Project  
CVTA, Virginia  
Wayfinding for Fall Line Trail

© 2024 AB Design, Inc.

**HE.16**

PROGRAMMING  
Sign Types  
Henrico

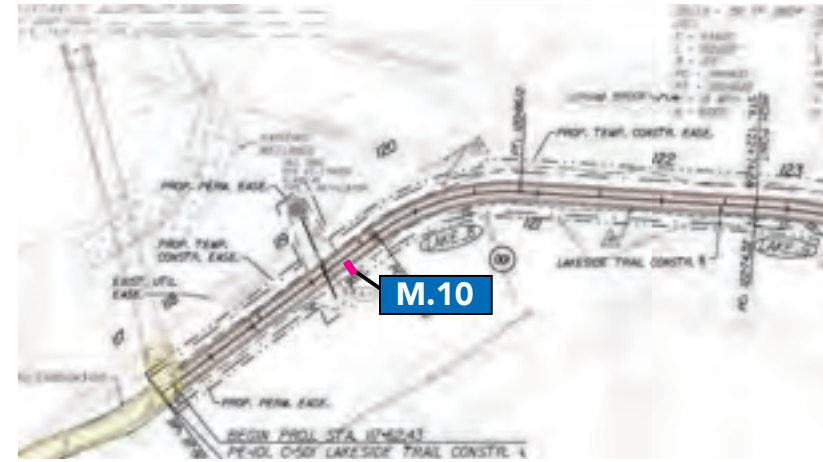
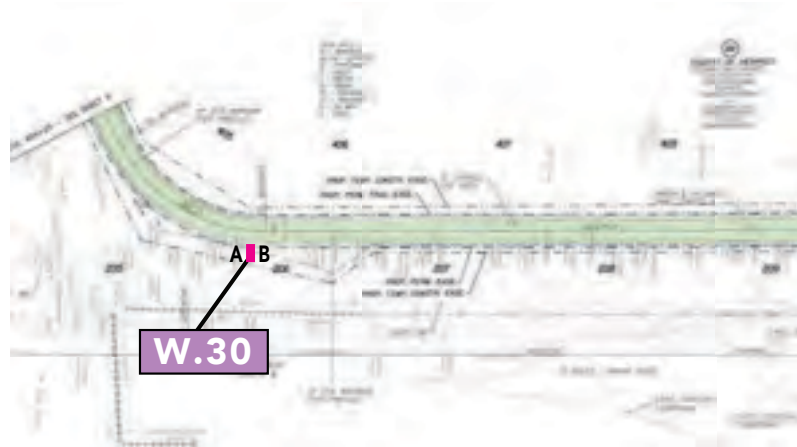

Sign Type W.30A  
Directional Sign



W.30B



Sign Type W.31A  
Directional Sign



W.31B

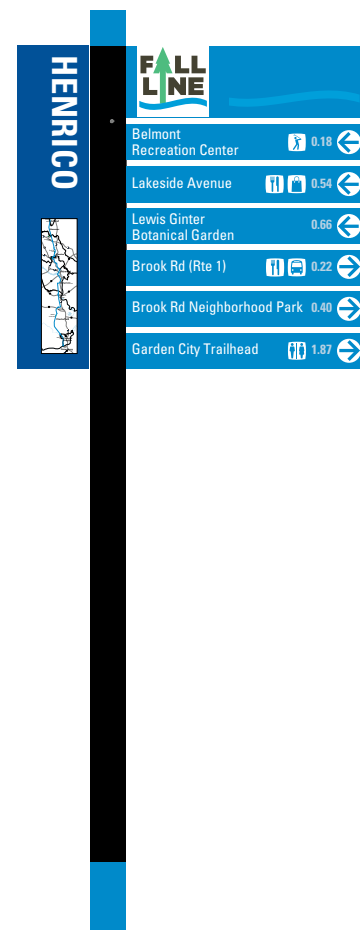

Sign Type P2.30A  
Pedestrian Directional

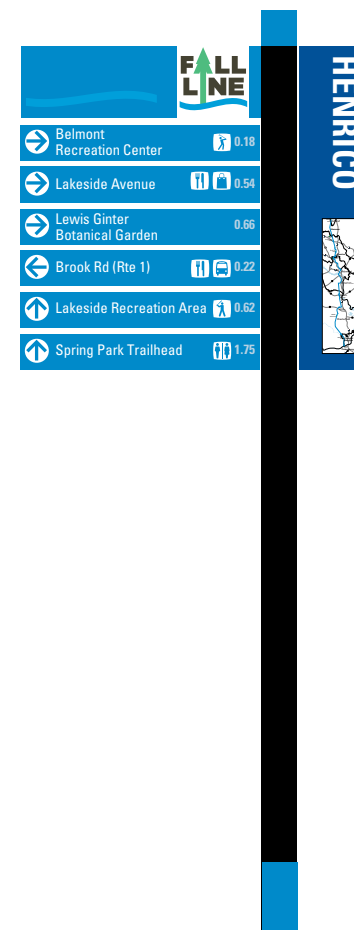

Sign Type P2.30B  
Pedestrian Directional



Sign Type M.10  
Mile Marker



THIS DRAWING REPRESENTS DESIGN INTENT ONLY.

Date	Revisions	Scale
12.4.23	2.2.24 5.21.24 2.26.24 4.11.24	3/4"=1'

Client/Project  
CVTA, Virginia  
Wayfinding for Fall Line Trail

© 2024 AB Design, Inc.

PROGRAMMING  
Sign Types  
Henrico

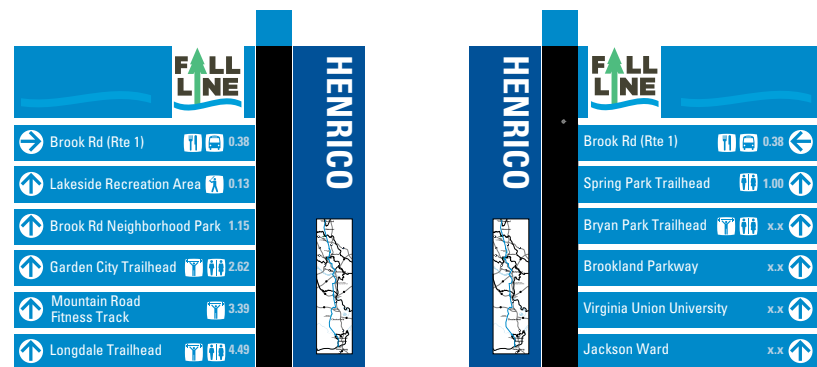
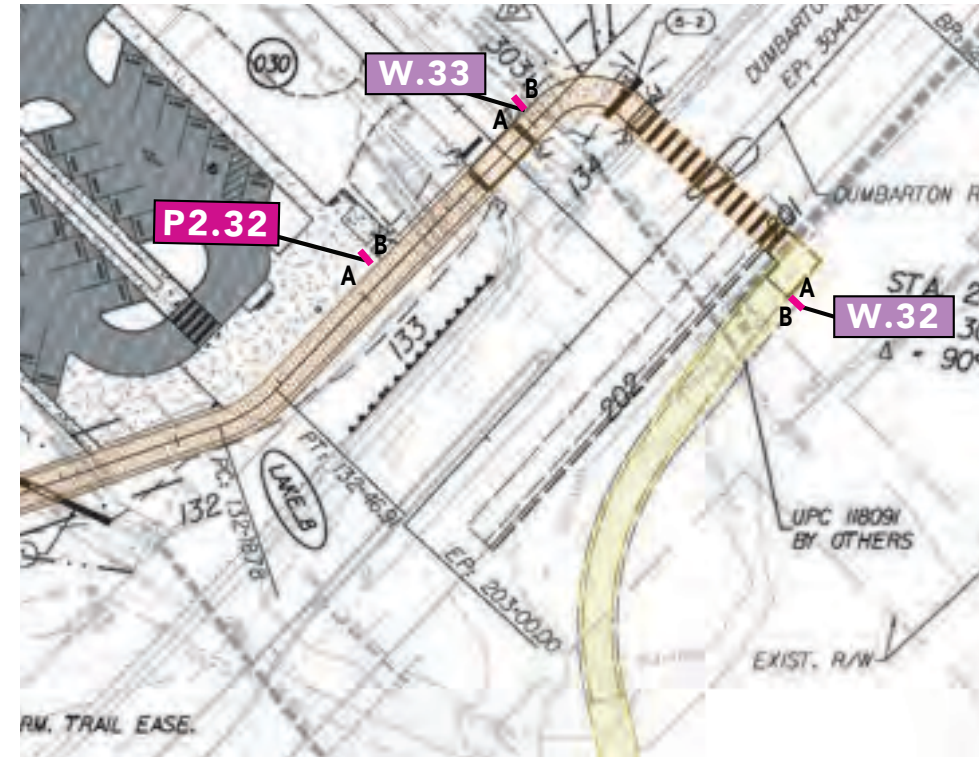
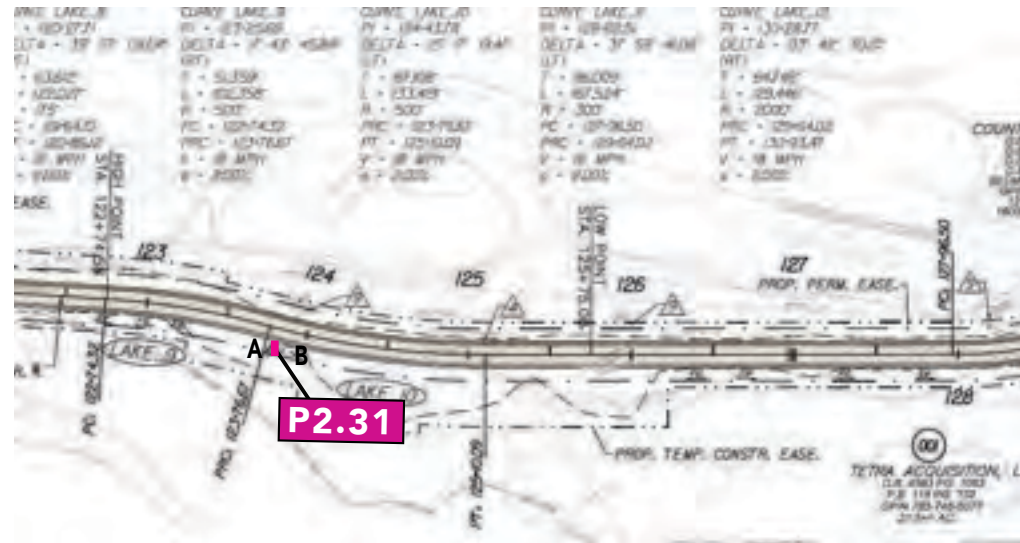
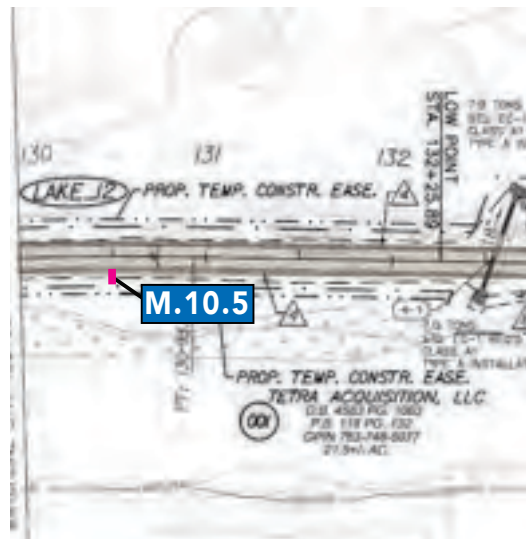

Sign Type M.10.5  
Mile Marker

Sign Type P2.31A  
Pedestrian Directional

Sign Type P2.31B  
Pedestrian Directional

Sign Type W.32A  
Directional Sign

W.32B

Sign Type W.33A  
Directional Sign

W.33B

THIS DRAWING REPRESENTS DESIGN INTENT ONLY.

Date	Revisions	Scale
12.4.23	2.2.24	3/4" = 1'
	2.26.24	
	4.11.24	
	5.21.24	
	5.28.24	

Client/Project  
CVTA, Virginia  
Wayfinding for Fall Line Trail

© 2024 AB Design, Inc.



PROGRAMMING  
Sign Types  
Henrico

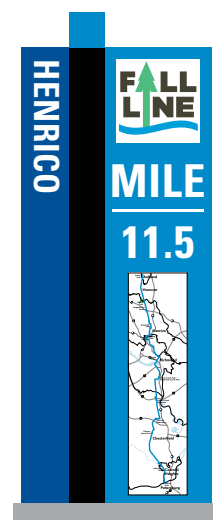
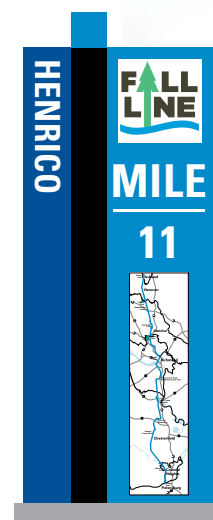
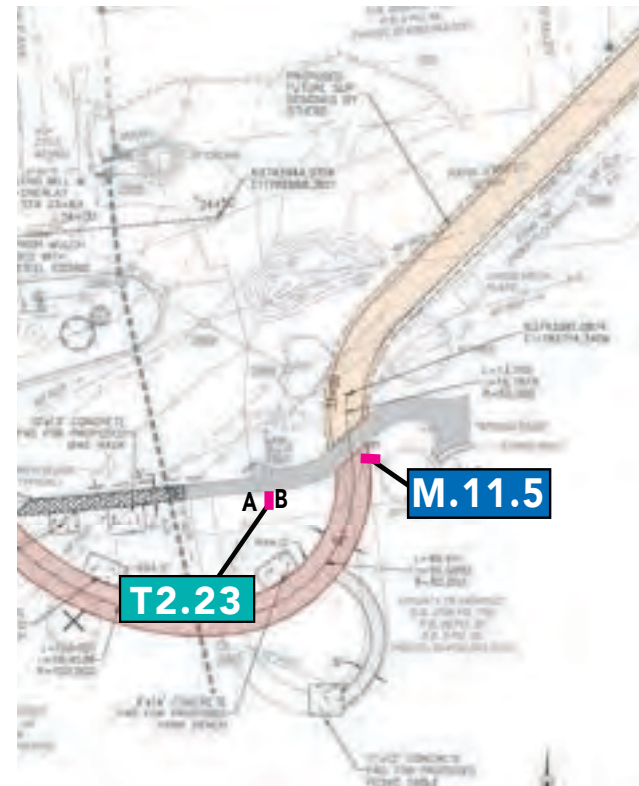
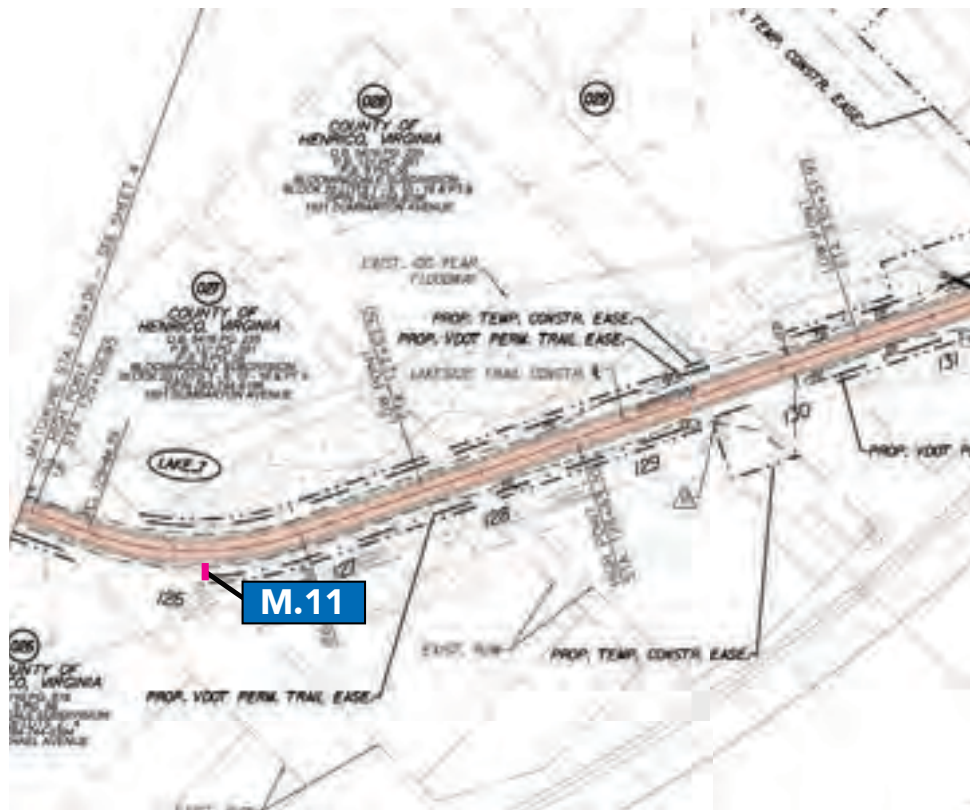

Sign Type P2.32A  
Pedestrian Directional

Sign Type P2.32B  
Pedestrian Directional

Sign Type M.11  
Mile Marker

Sign Type M.11.5  
Mile Marker

Sign Type T2.23A  
Pedestrian Trailhead/  
Regulatory Sign

Sign Type T2.23B  
Pedestrian Trailhead/  
Regulatory Sign

THIS DRAWING REPRESENTS DESIGN INTENT ONLY.

Date	Revisions	2.26.24	5.28.24	Scale
10.27.23	11.6.23	2.26.24	5.28.24	3/4" = 1'
	12.4.23	4.11.24		
	2.2.24	5.21.24		

Client/Project  
CVTA, Virginia  
Wayfinding for Fall Line Trail

© 2024 AB Design, Inc.



Sign Type T1.27A  
Vehicular  
Trailhead Sign



Sign Type T1.27B  
Vehicular  
Trailhead Sign



Sign Type T1.28A  
Vehicular  
Trailhead Sign



Sign Type T1.28B  
Vehicular  
Trailhead Sign

PROGRAMMING  
Sign Types  
Henrico

THIS DRAWING REPRESENTS DESIGN INTENT ONLY.

Date 10.27.23	Revisions		Scale 3/4" = 1'
	11.6.23	2.26.24	
	12.4.23	4.11.24	
	2.2.24	5.21.24	

Client/Project  
CVTA, Virginia  
Wayfinding for Fall Line Trail

© 2024 AB Design, Inc.

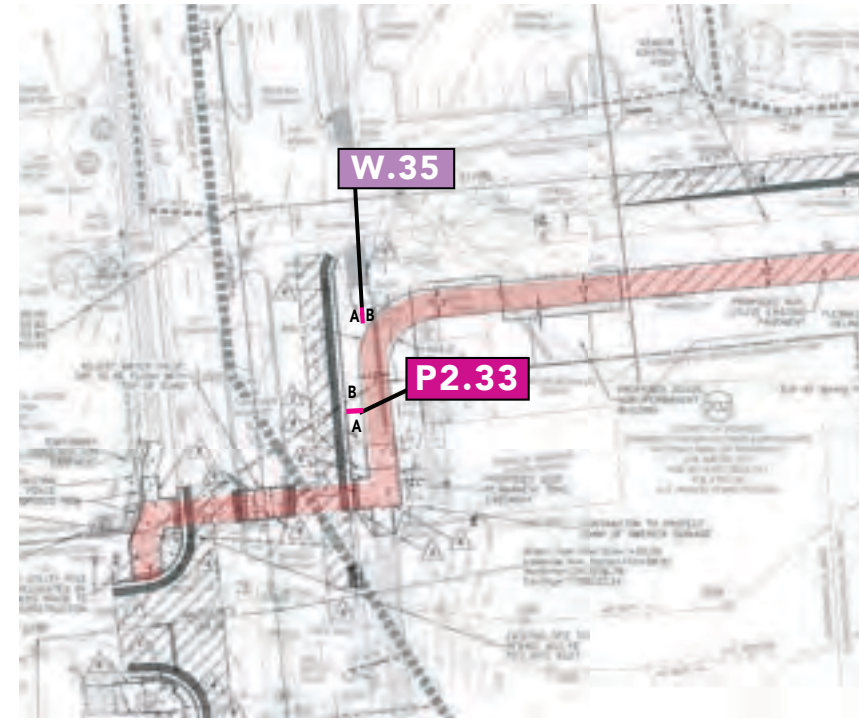

PROGRAMMING  
Sign Types  
Henrico

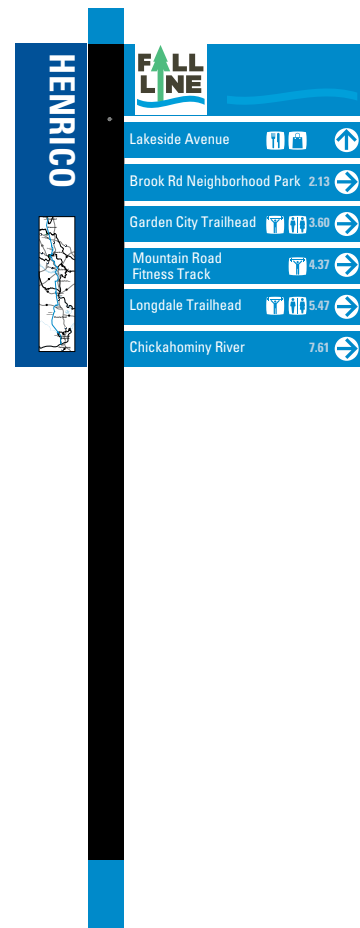

Sign Type P2.33A  
Pedestrian Directional

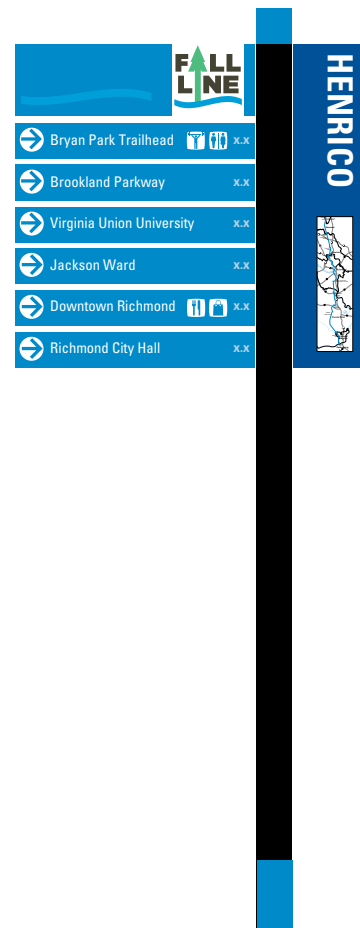

Sign Type P2.33B  
Pedestrian Directional



Sign Type W.35A  
Directional Sign



W.35B

THIS DRAWING REPRESENTS DESIGN INTENT ONLY.

Date	Revisions	Scale
10.27.23	11.6.23 2.26.24 5.28.24	3/4" = 1'
	12.4.23 4.11.24	
	2.2.24 5.21.24	

Client/Project  
CVTA, Virginia  
Wayfinding for Fall Line Trail

© 2024 AB Design, Inc.

June 2024



# CVTA Wayfinding for Fall Line Trail

Programming  
Richmond



1005 Stonemill Road  
Richmond, Virginia 23233  
Phone: 804-346-4771  
Fax: 804-325-1751  
[www.abdesignonline.com](http://www.abdesignonline.com)



**PROGRAMMING**  
 Sign Location Plan  
 RICHMOND



**SIGNTYPES KEY**

- ID Landmark Id.
- M Mile marker
- P Pedestrian Directional
- PL Plate
- T Trailhead Sign
- U Urban/ParkingMarker
- V Vehicular Directional
- W Directional
- Trail Access Point

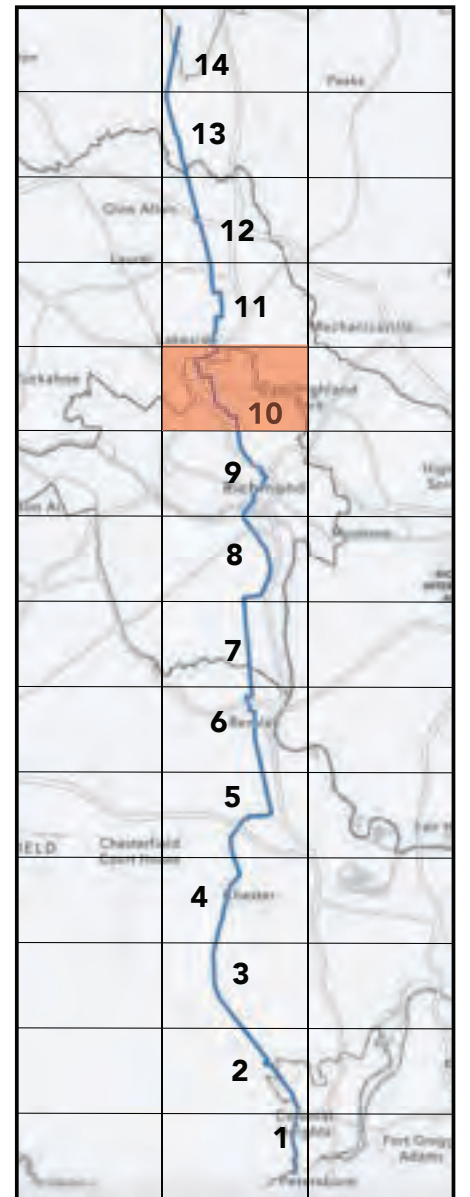

THIS DRAWING REPRESENTS DESIGN INTENT ONLY.

Date 4.22.24	Revisions 6.6.24	Scale NTS
-----------------	---------------------	--------------

Client/Project  
 CVTA, Virginia  
 Wayfinding for Fall Line Trail

PROGRAMMING  
Sign Types  
RICHMOND



Sign Type W.41A  
Directional Sign

W.41B



Sign Type T1.41A  
Vehicular  
Trailhead Sign



Sign Type T1.41B  
Vehicular  
Trailhead Sign



Sign Type P1.41A  
Pedestrian Directional

Sign Type P1.41B  
Pedestrian Directional

THIS DRAWING REPRESENTS DESIGN INTENT ONLY.

Date 4.22.24	Revisions 6.6.24	Scale 3/4"=1'
-----------------	---------------------	------------------

Client/Project  
CVTA, Virginia  
Wayfinding for Fall Line Trail

© 2024 AB Design, Inc.

PROGRAMMING

Sign Types  
RICHMOND



Sign Type W.42A Directional Sign    W.42B    Sign Type M.12 Mile Marker    Sign Type W.43A Directional Sign    W.43B    Sign Type T2.41A Pedestrian TrailRad/Regulatory Sign    Sign Type T2.41B Pedestrian TrailRad/Regulatory Sign    Sign Type M.12.5 Mile Marker

THIS DRAWING REPRESENTS DESIGN INTENT ONLY.

Date	Revisions	Scale
4.22.24	6.6.24	3/4" = 1'

Client/Project  
CVTA, Virginia  
Wayfinding for Fall Line Trail

PROGRAMMING

Sign Types  
RICHMOND

We recommend the use of street pavers with the logotype along Bellevue Avenue and Hermitage Road to reinforce the route of the trail.



Sign Type T2.42A  
Pedestrian TrailRad/  
Regulatory Sign



Sign Type T2.42B  
Pedestrian TrailRad/  
Regulatory Sign

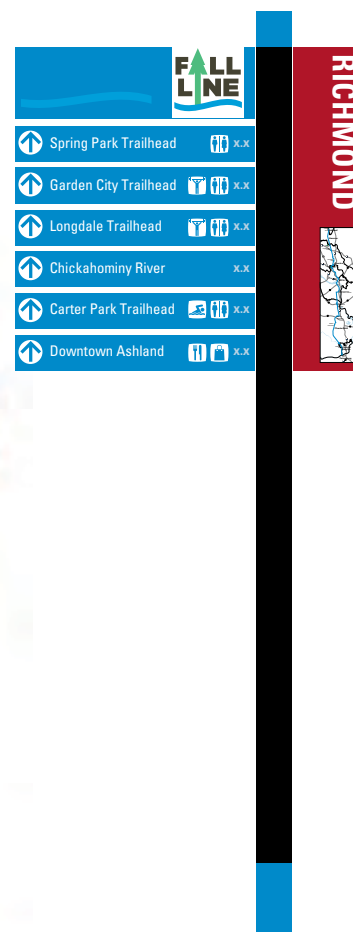

Sign Type P2.41A  
Pedestrian Directional

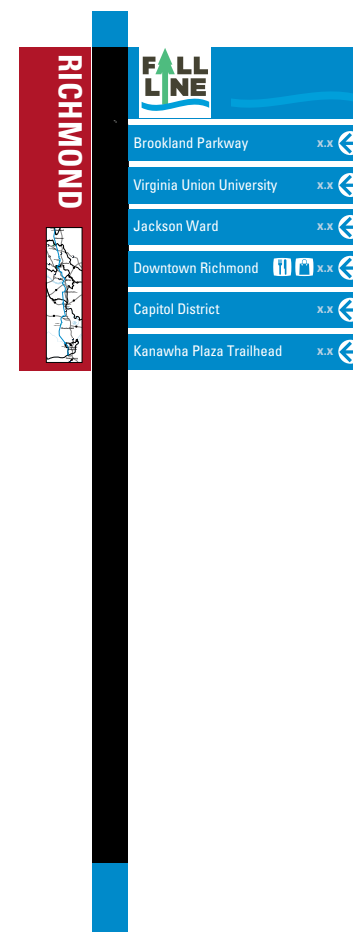

Sign Type P2.41B  
Pedestrian Directional



Sign Type W.44A  
Directional Sign



W.44B

THIS DRAWING REPRESENTS DESIGN INTENT ONLY.

Date 4.22.24	Revisions 6.6.24	Scale 3/4" = 1'
-----------------	---------------------	--------------------

Client/Project  
CVTA, Virginia  
Wayfinding for Fall Line Trail

© 2024 AB Design, Inc.



PROGRAMMING  
Sign Types  
RICHMOND

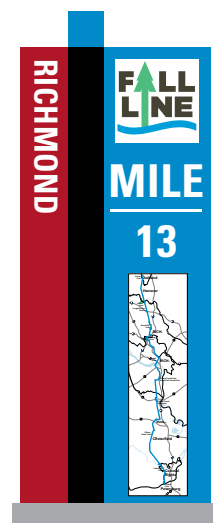

Sign Type M.13  
Mile Marker



Sign Type W.45A  
Directional Sign



W.45B

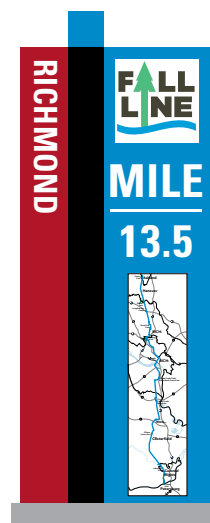

Sign Type M.13.5  
Mile Marker



Sign Type W.46A  
Directional Sign



W.46B

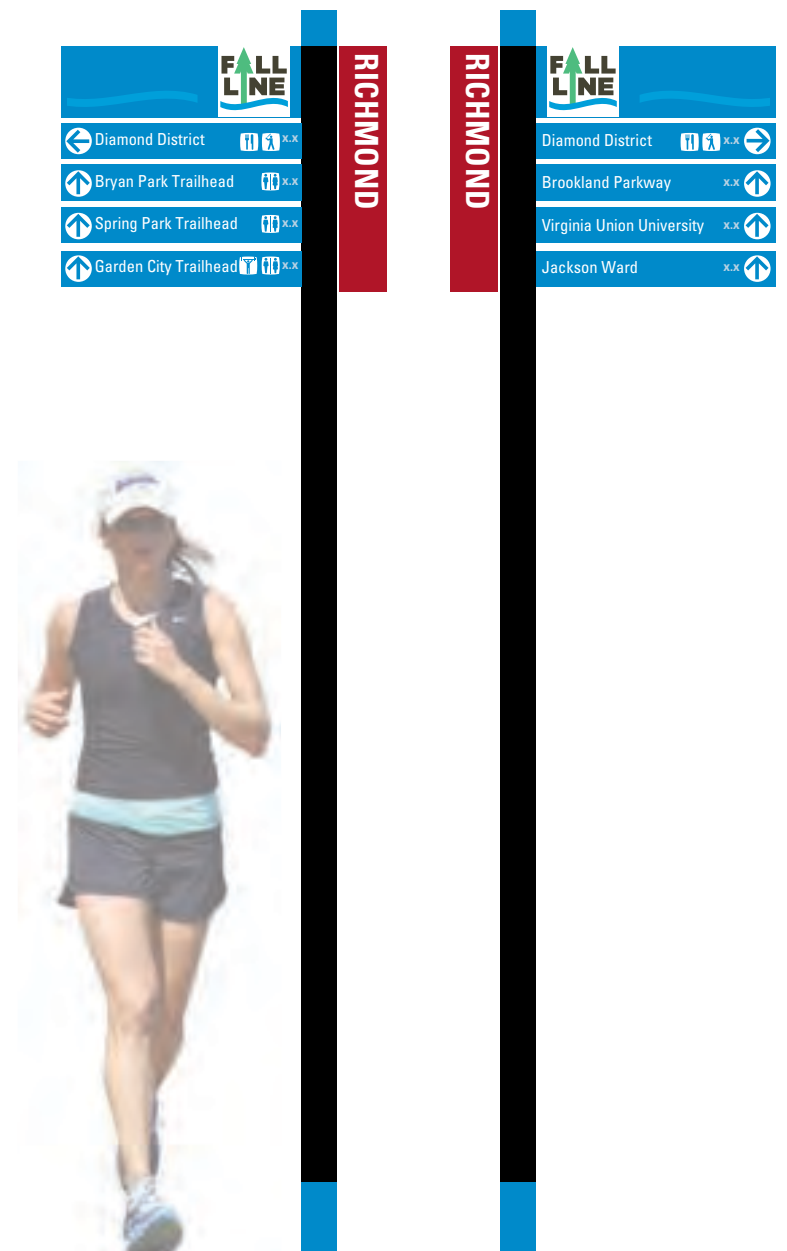

Sign Type P1.42A  
Pedestrian Directional

Sign Type P1.42B  
Pedestrian Directional

THIS DRAWING REPRESENTS DESIGN INTENT ONLY.

Date 4.22.24	Revisions 6.6.24	Scale 3/4" = 1'
-----------------	---------------------	--------------------

Client/Project  
CVTA, Virginia  
Wayfinding for Fall Line Trail

© 2024 AB Design, Inc.



**PROGRAMMING**  
Sign Location Plan  
Richmond

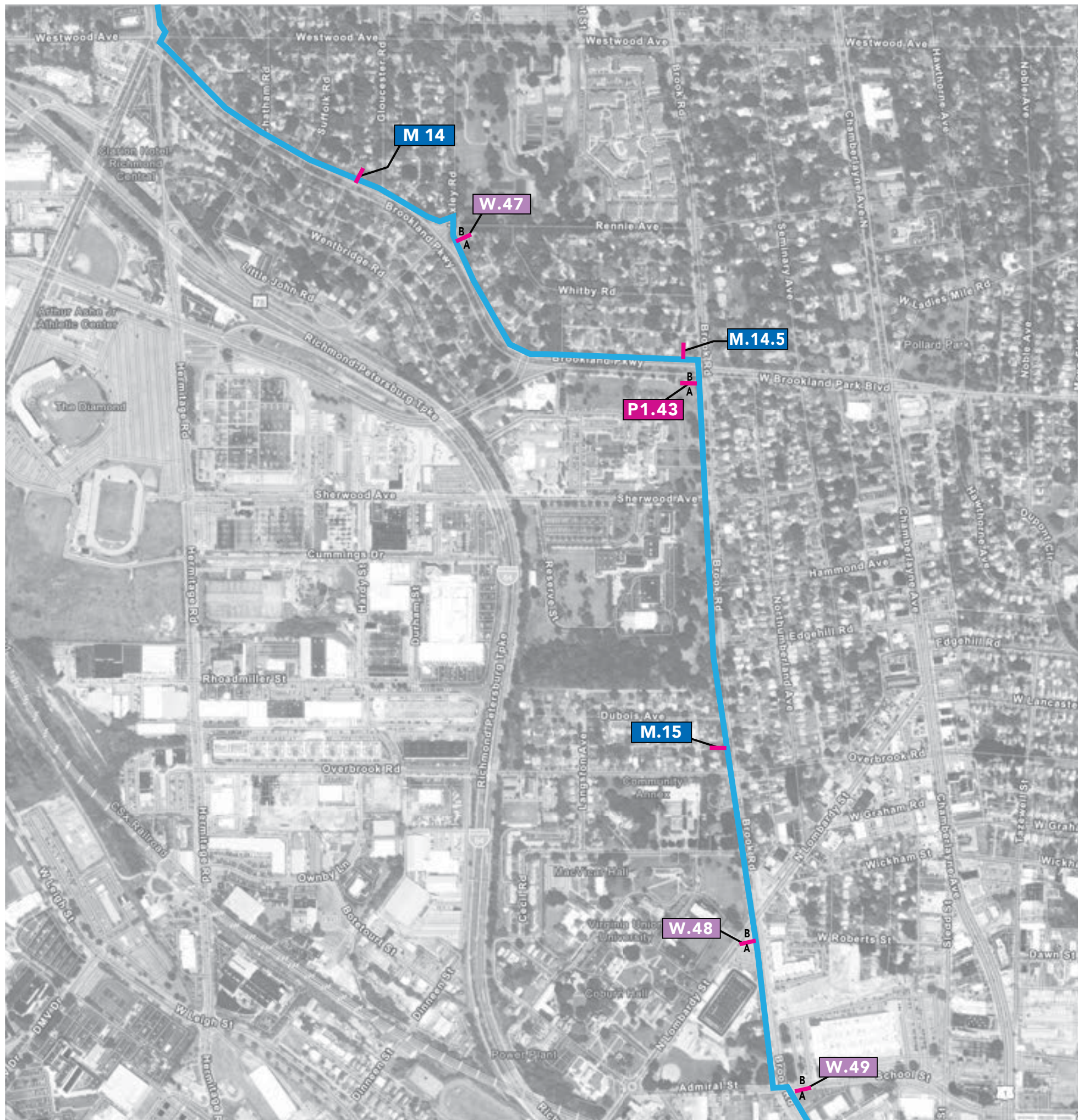

**SIGNTYPES KEY**

- ID Landmark Id.
- M Mile marker
- P Pedestrian Directional
- PL Plate
- T Trailhead Sign
- U Urban/ParkingMarker
- V Vehicular Directional
- W Directional
- Trail Access Point

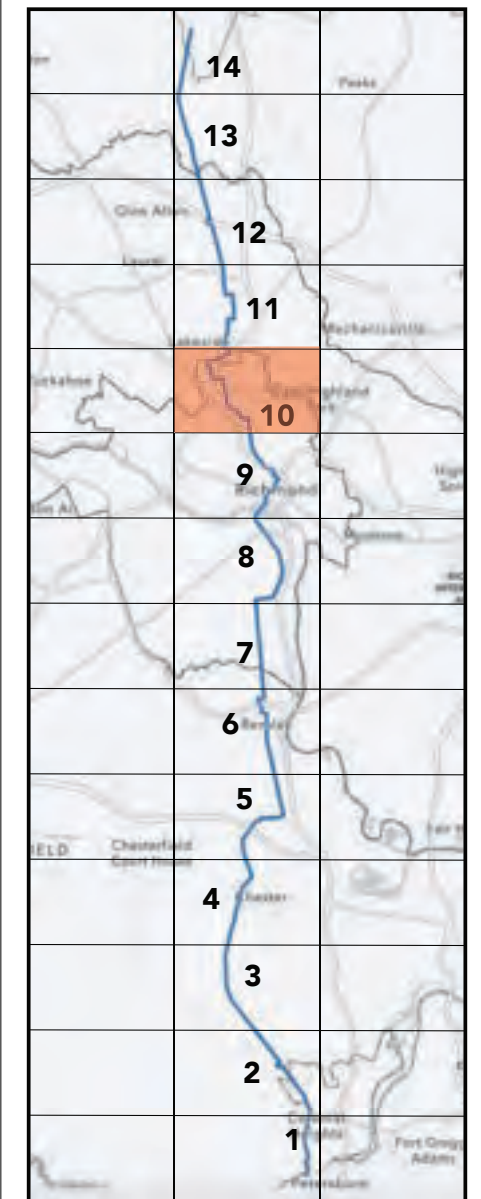

THIS DRAWING REPRESENTS DESIGN INTENT ONLY.

Date 4.22.24	Revisions 6.6.24	Scale NTS
-----------------	---------------------	--------------

Client/Project  
CVTA, Virginia  
Wayfinding for Fall Line Trail



**PROGRAMMING**  
Sign Location Plan  
Richmond

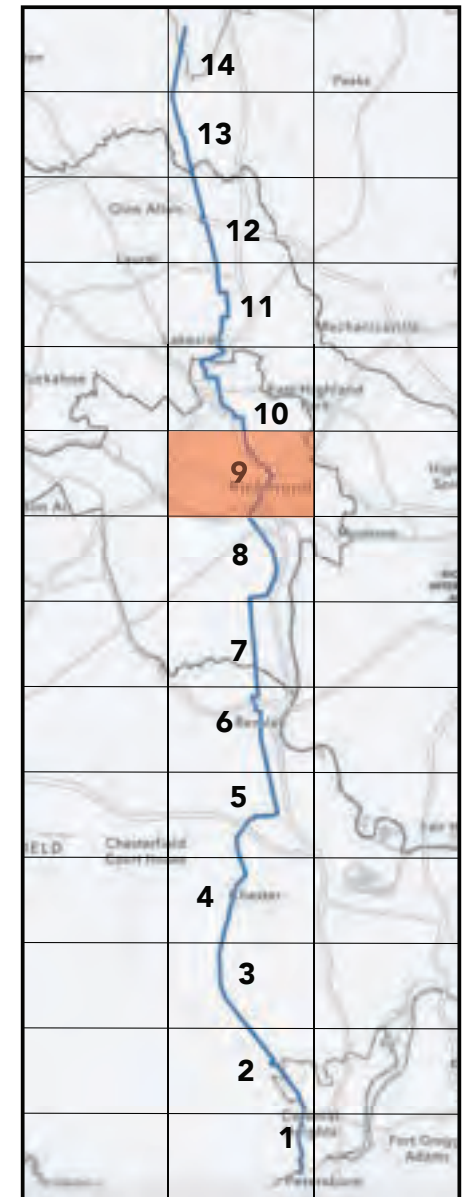

**SIGNTYPES KEY**

ID	Landmark Id.
M	Mile marker
P	Pedestrian Directional
PL	Plate
T	Trailhead Sign
U	Urban/ParkingMarker
V	Vehicular Directional
W	Directional
●	Trail Access Point

THIS DRAWING REPRESENTS DESIGN INTENT ONLY.

Date 4.22.24	Revisions 6.6.24	Scale NTS
-----------------	---------------------	--------------

Client/Project  
CVTA, Virginia  
Wayfinding for Fall Line Trail

**R.7**

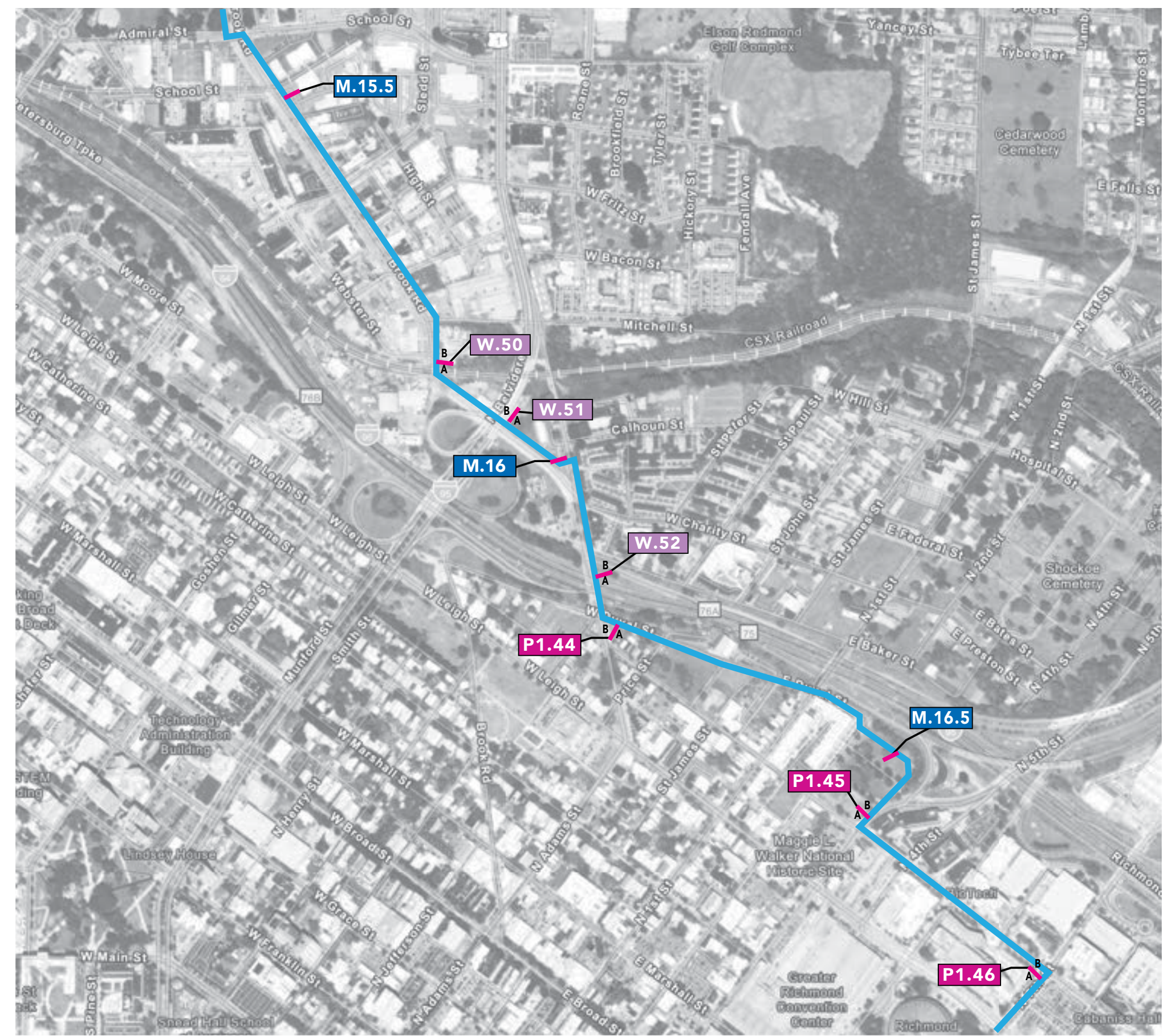

We recommend the use of street pavers with the logotype along Brookland Parkway and Brooke Road to reinforce the route of the trail.

PROGRAMMING

Sign Types  
Richmond

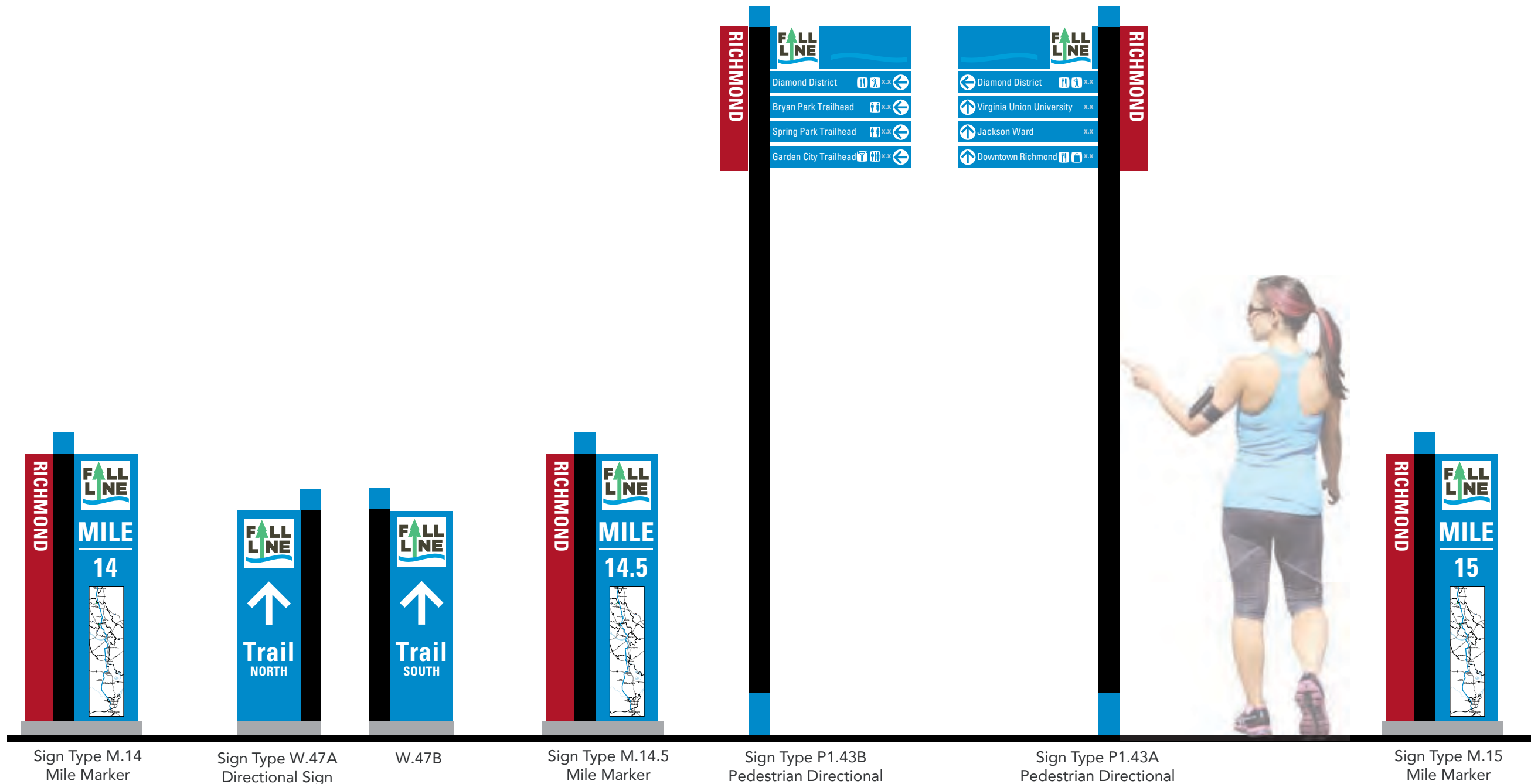

THIS DRAWING REPRESENTS DESIGN INTENT ONLY.

Date 4.22.24	Revisions 6.6.24	Scale 3/4"=1'
-----------------	---------------------	------------------

Client/Project  
CVTA, Virginia  
Wayfinding for Fall Line Trail

© 2024 AB Design, Inc.

PROGRAMMING

Sign Types  
Richmond



Sign Type W.48A  
Directional Sign

W.48B

Sign Type W.49A  
Directional Sign

W.49B

Sign Type M.15.5  
Mile Marker

Sign Type W.50A  
Directional Sign

W.50B

Sign Type W.51A  
Directional Sign

W.51B

THIS DRAWING REPRESENTS DESIGN INTENT ONLY.

Date 4.22.24	Revisions 6.6.24	Scale 3/4" = 1'
-----------------	---------------------	--------------------

Client/Project  
CVTA, Virginia  
Wayfinding for Fall Line Trail

© 2024 AB Design, Inc.

We recommend the use of street pavers with the logotype along Brooke Road, Duval St., E Jackson St. and 7th St. to reinforce the route of the trail.

PROGRAMMING

Sign Types  
Richmond

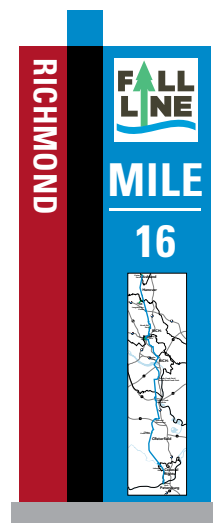

Sign Type M.16  
Mile Marker



Sign Type W.52A  
Directional Sign



W.52B

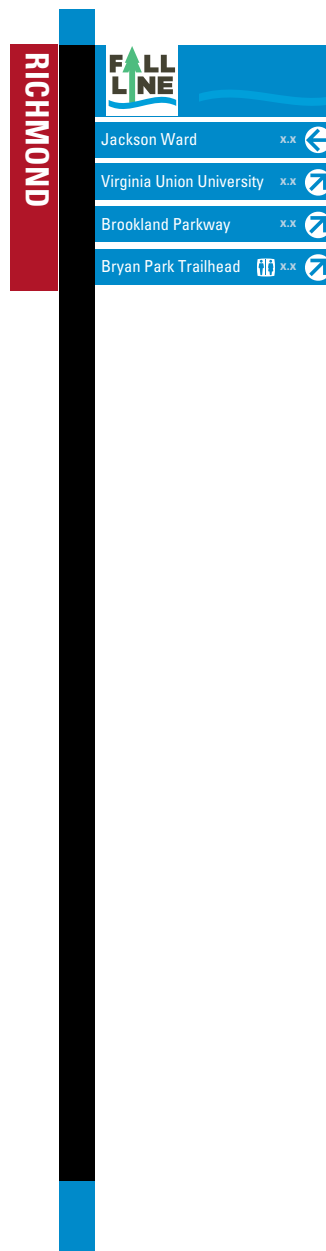

Sign Type P1.44A  
Pedestrian Directional

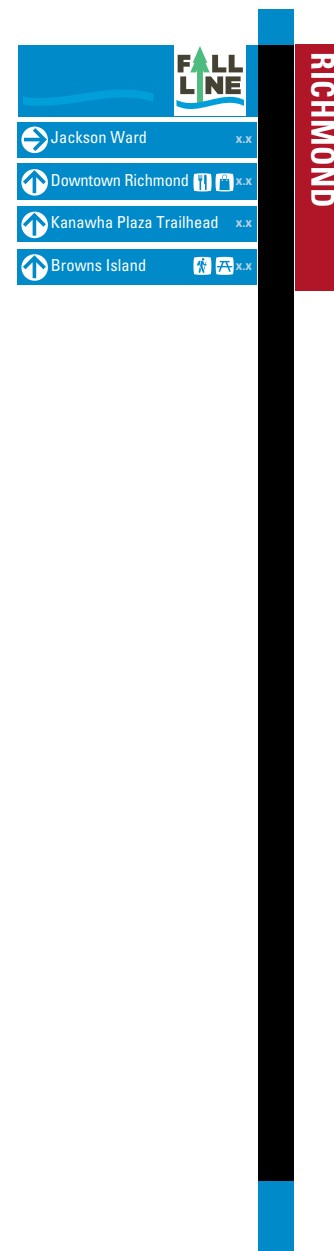

Sign Type P1.44B  
Pedestrian Directional

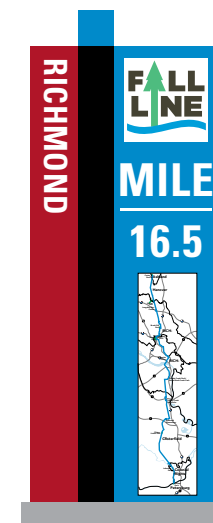

Sign Type M.16.5  
Mile Marker

THIS DRAWING REPRESENTS DESIGN INTENT ONLY.

Date 4.22.24	Revisions 6.6.24	Scale 3/4" = 1'
-----------------	---------------------	--------------------

Client/Project  
CVTA, Virginia  
Wayfinding for Fall Line Trail

© 2024 AB Design, Inc.

We recommend the use of street pavers with the logotype along Brooke Road, Duval St., E Jackson St. and 7th St. to reinforce the route of the trail.

PROGRAMMING

Sign Types  
Richmond

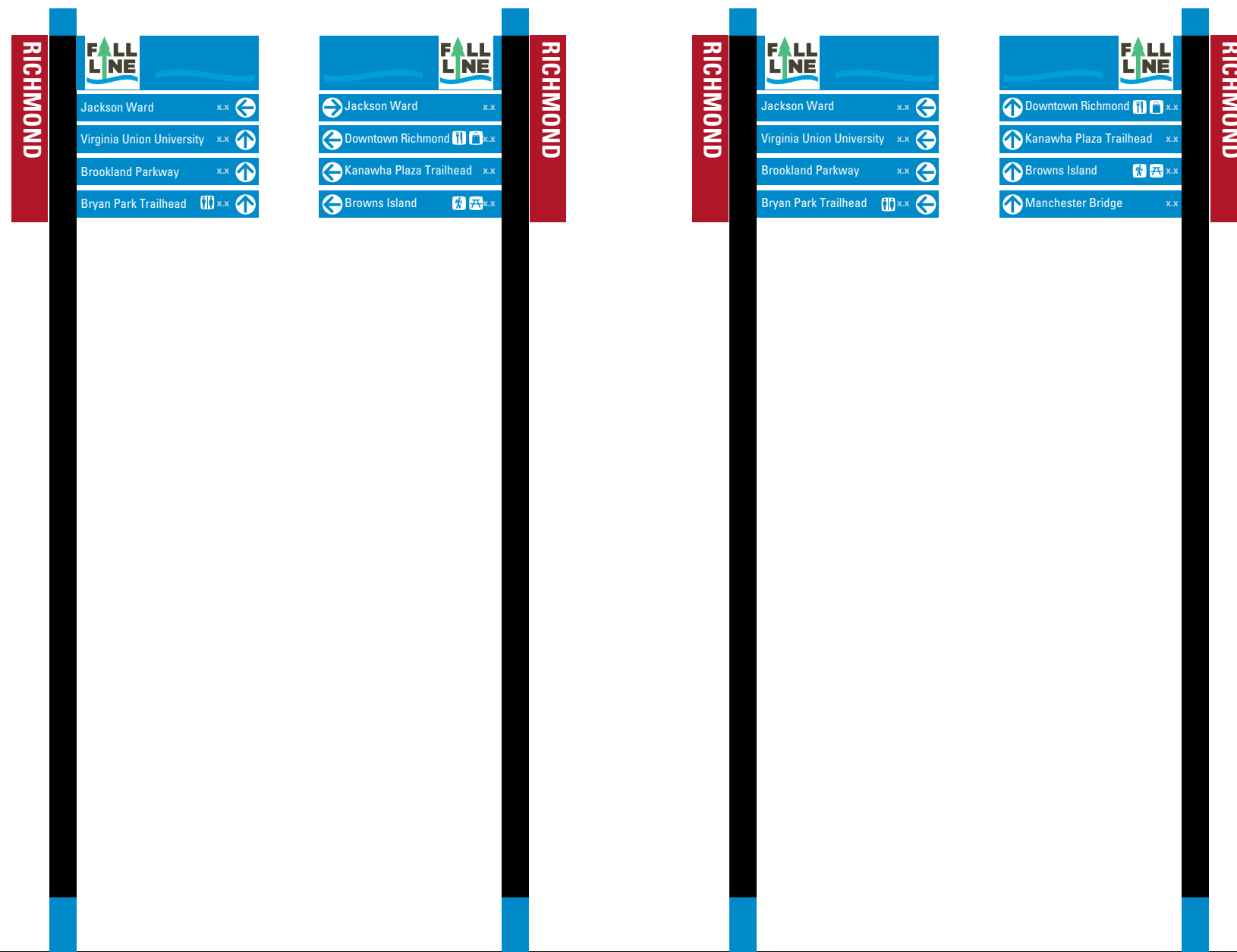

Sign Type P1.45A  
Pedestrian Directional

Sign Type P1.45B  
Pedestrian Directional

Sign Type P1.46A  
Pedestrian Directional

Sign Type P1.46B  
Pedestrian Directional

THIS DRAWING REPRESENTS DESIGN INTENT ONLY.

Date 4.22.24	Revisions 6.6.24	Scale 3/4" = 1'
-----------------	---------------------	--------------------

Client/Project  
CVTA, Virginia  
Wayfinding for Fall Line Trail



**PROGRAMMING**  
Sign Location Plan  
Richmond

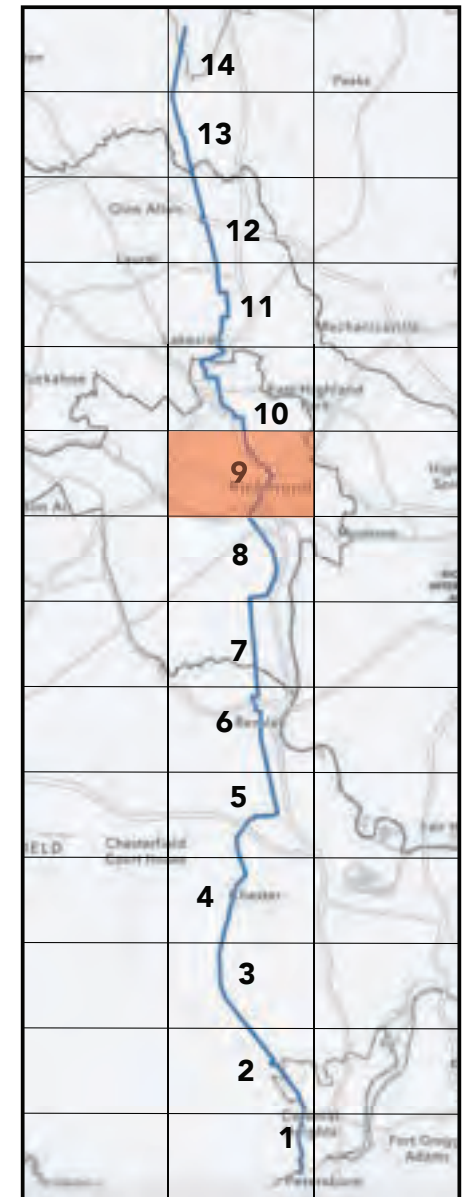

THIS DRAWING REPRESENTS DESIGN INTENT ONLY.

Date 4.22.24	Revisions 6.6.24	Scale NTS
-----------------	---------------------	--------------

Client/Project  
CVTA, Virginia  
Wayfinding for Fall Line Trail

© 2024 AB Design, Inc.

**R.12**

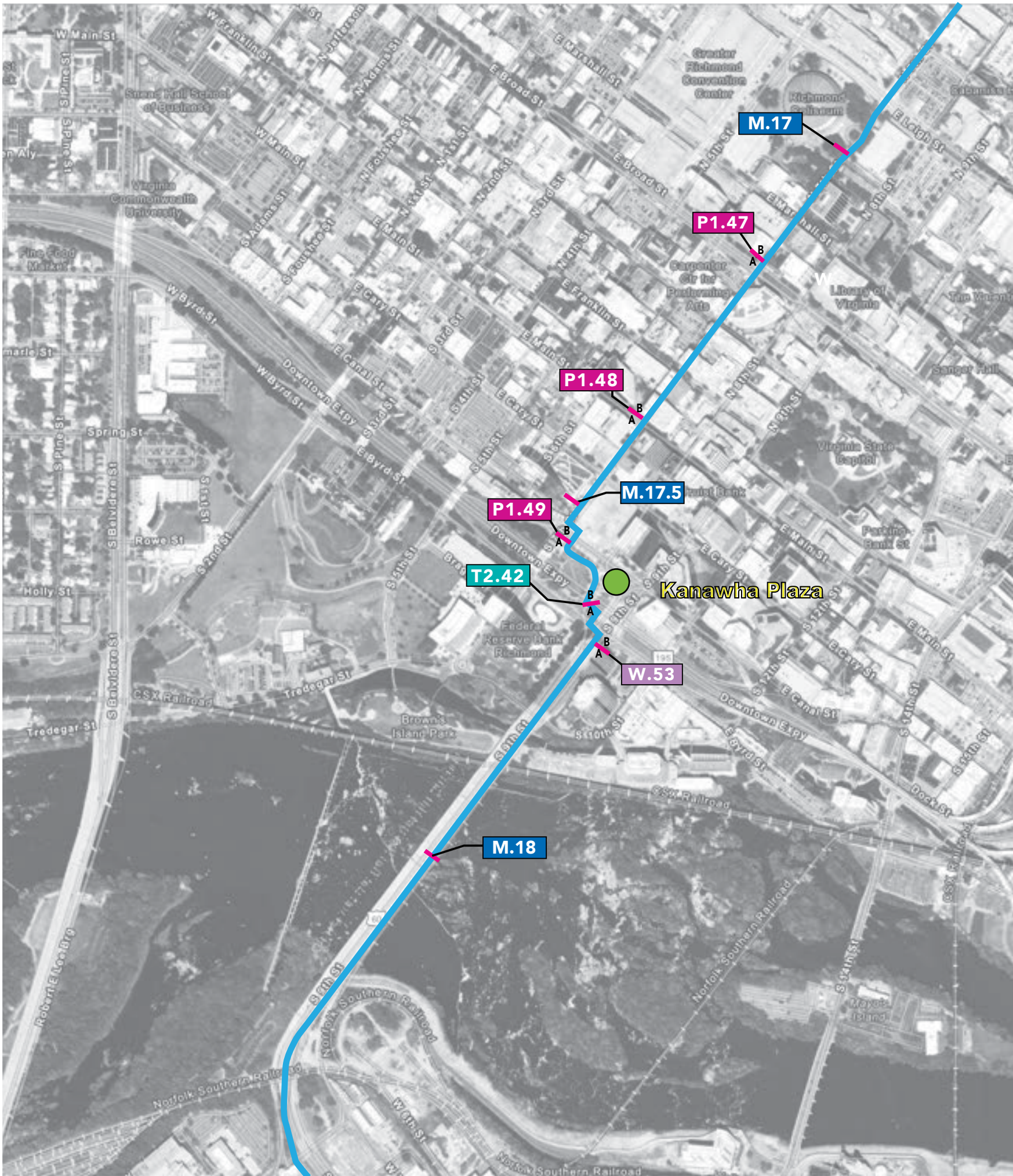

**SIGNTYPES KEY**

ID	Landmark Id.
M	Mile marker
P	Pedestrian Directional
PL	Plate
T	Trailhead Sign
U	Urban/ParkingMarker
V	Vehicular Directional
W	Directional
●	Trail Access Point





**PROGRAMMING**  
Sign Location Plan  
Richmond

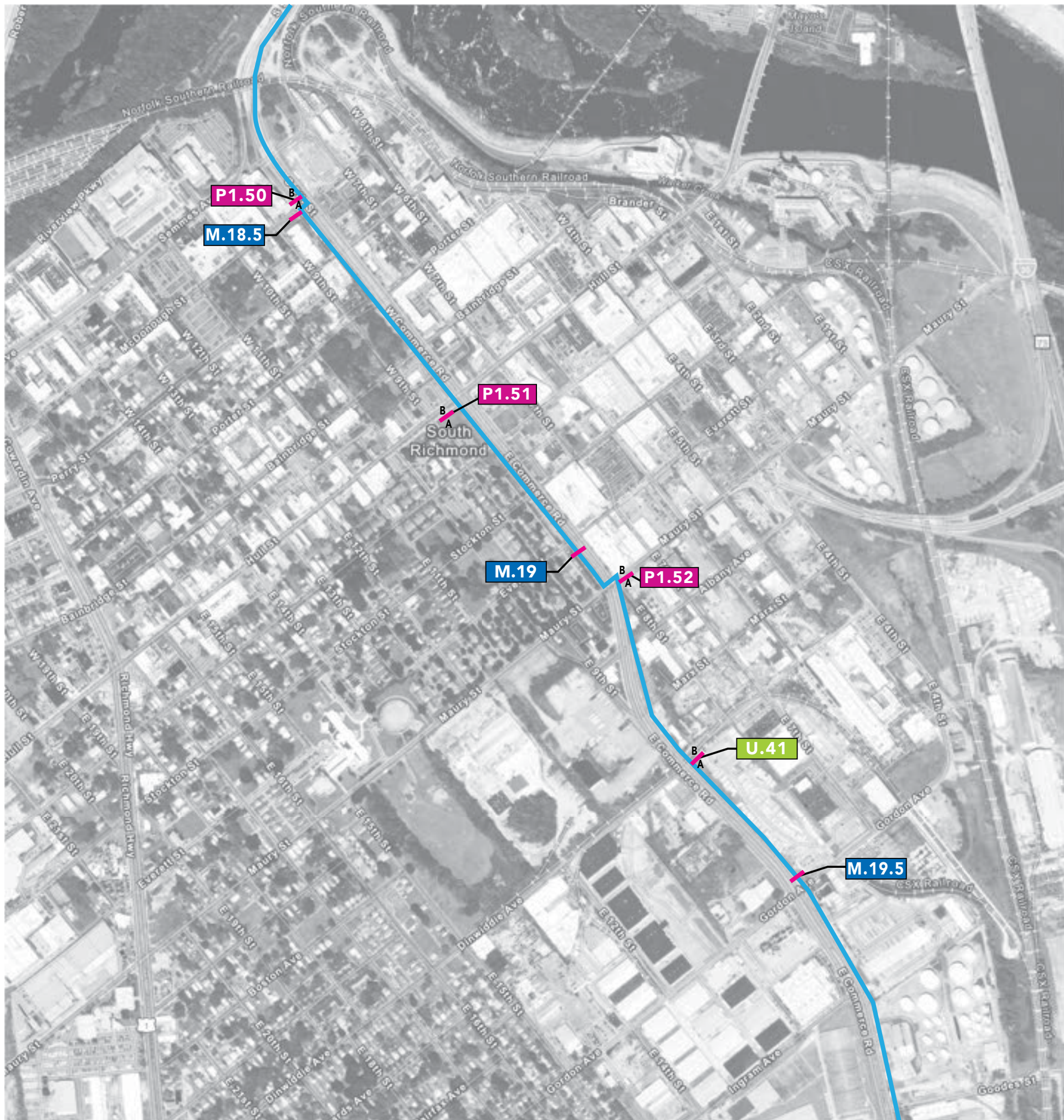

**SIGNTYPES KEY**

ID	Landmark Id.
M	Mile marker
P	Pedestrian Directional
PL	Plate
T	Trailhead Sign
U	Urban/ParkingMarker
V	Vehicular Directional
W	Directional
●	Trail Access Point

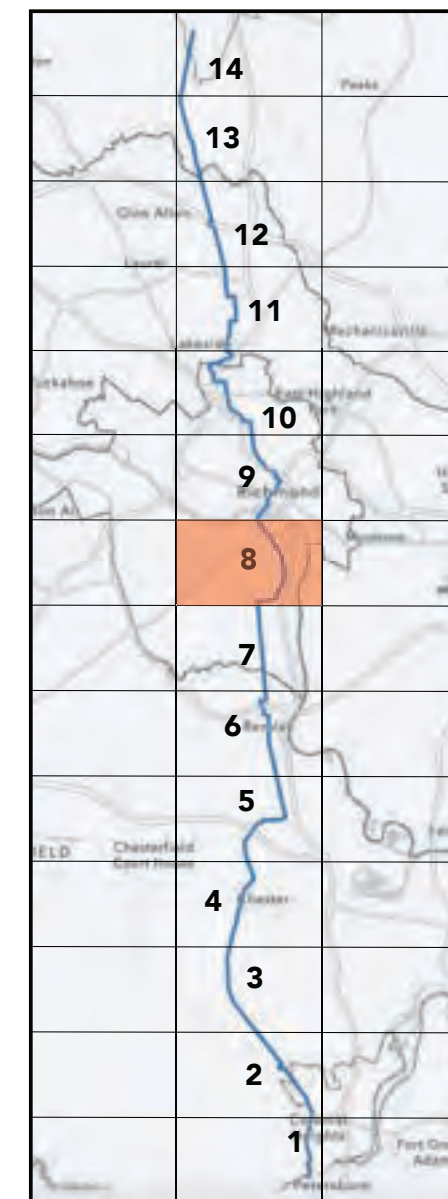

THIS DRAWING REPRESENTS DESIGN INTENT ONLY.

Date 4.22.24	Revisions 6.6.24	Scale NTS
-----------------	---------------------	--------------

Client/Project  
CVTA, Virginia  
Wayfinding for Fall Line Trail

**R.13**

We recommend the use of street pavers with the logotype along 7th St. and the 9th St. Manchester Bridge to reinforce the route of the trail.

PROGRAMMING

Sign Types  
Richmond

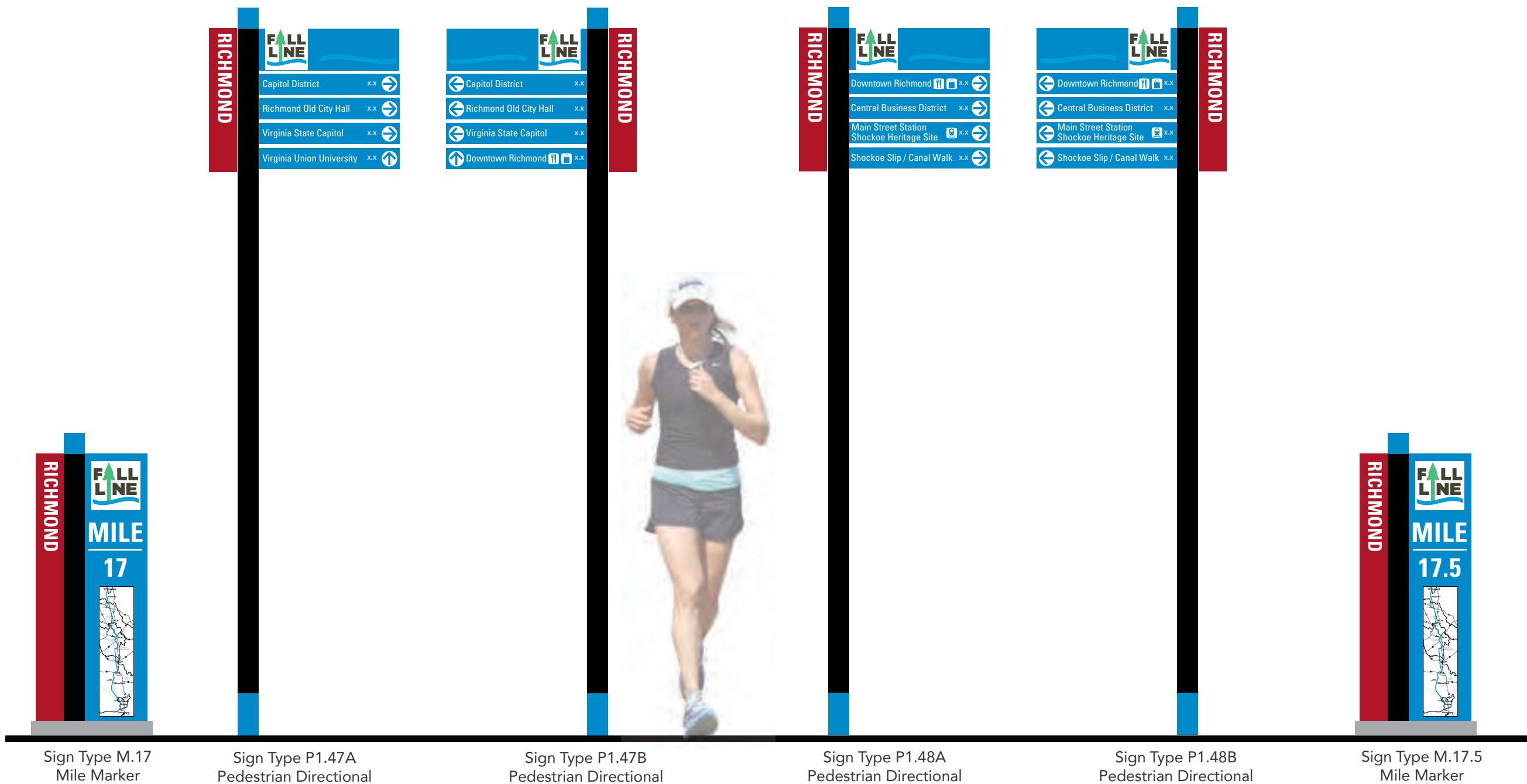

THIS DRAWING REPRESENTS DESIGN INTENT ONLY.

Date 4.22.24	Revisions 6.6.24	Scale 3/4" = 1'
-----------------	---------------------	--------------------

Client/Project  
CVTA, Virginia  
Wayfinding for Fall Line Trail

© 2024 AB Design, Inc.

PROGRAMMING

Sign Types  
Richmond

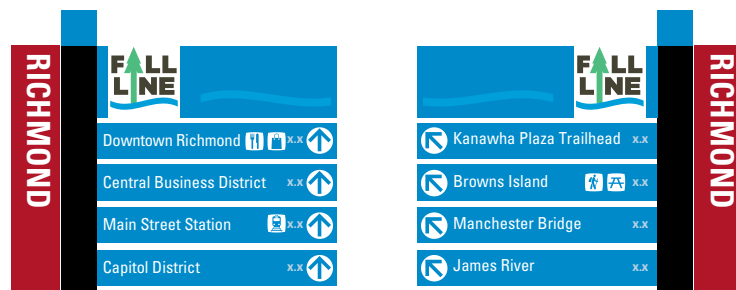

Sign Type P1.49A  
Pedestrian Directional

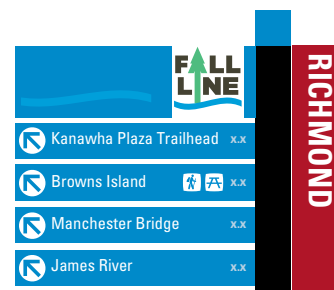

Sign Type P1.49B  
Pedestrian Directional



Sign Type T2.42A  
Pedestrian TrailRad/  
Regulatory Sign



Sign Type T2.42B  
Pedestrian TrailRad/  
Regulatory Sign



Sign Type W.53A  
Directional Sign



W.53B

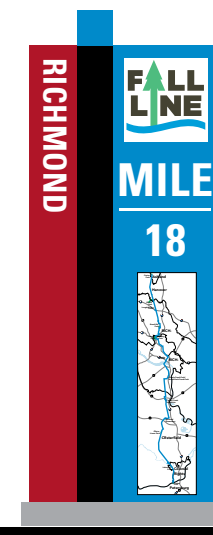

Sign Type M.18  
Mile Marker

THIS DRAWING REPRESENTS DESIGN INTENT ONLY.

Date 12.4.23	Revisions 6.6.24	Scale 3/4" = 1'
-----------------	---------------------	--------------------

Client/Project  
CVTA, Virginia  
Wayfinding for Fall Line Trail

© 2024 AB Design, Inc.

We recommend the use of street pavers along Commerce Rd. to reinforce the route of the trail.

PROGRAMMING

Sign Types  
Richmond

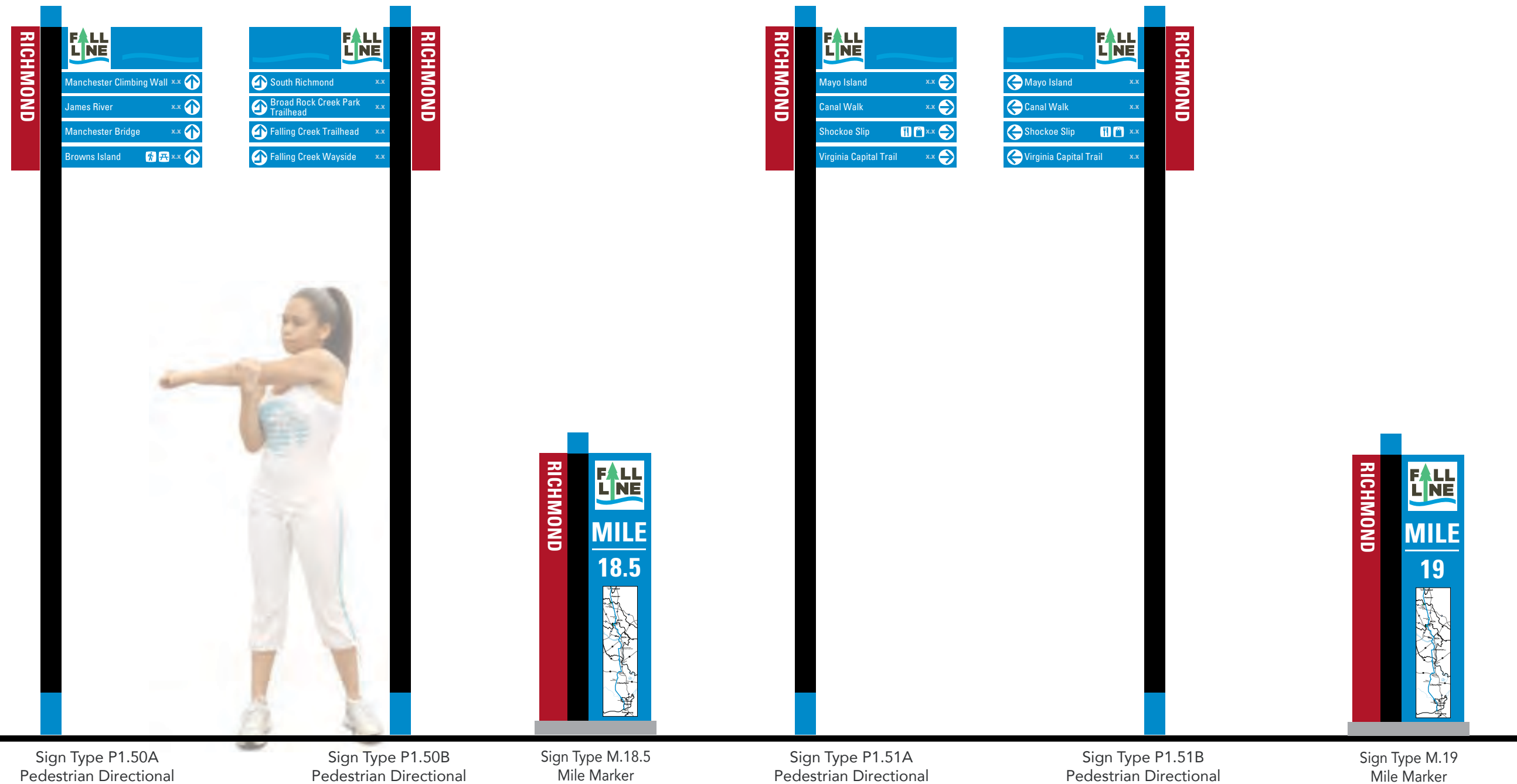

THIS DRAWING REPRESENTS DESIGN INTENT ONLY.

Date 4.22.24	Revisions 6.6.24	Scale 3/4" = 1'
-----------------	---------------------	--------------------

Client/Project  
CVTA, Virginia  
Wayfinding for Fall Line Trail

© 2024 AB Design, Inc.

PROGRAMMING

Sign Types  
Richmond

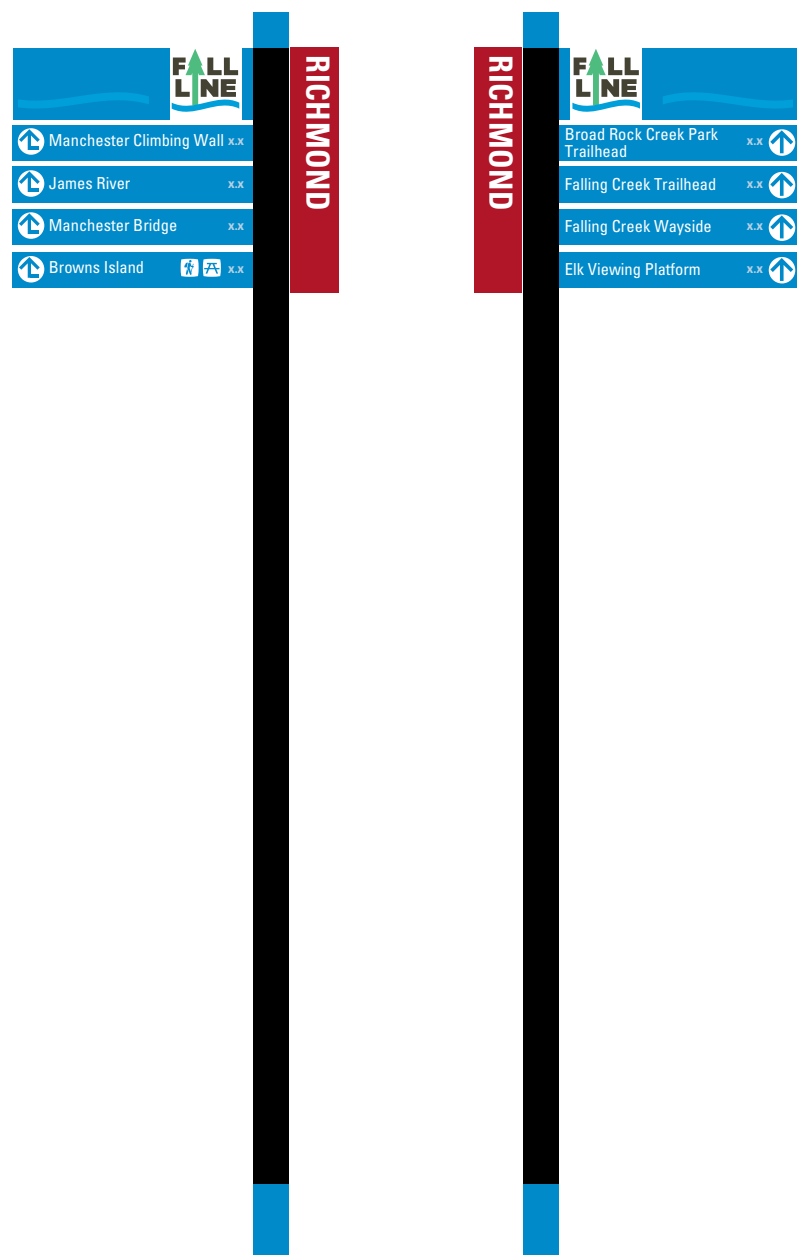

Sign Type P1.52A  
Pedestrian Directional

Sign Type P1.52B  
Pedestrian Directional

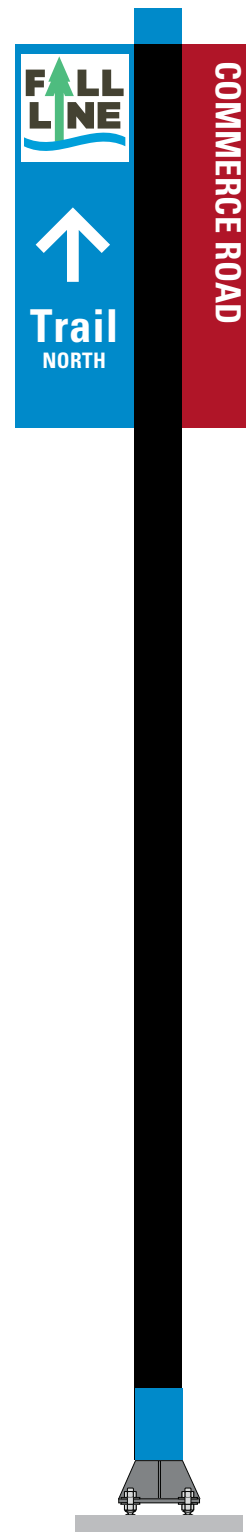

Sign Type U.41A  
Urban marker

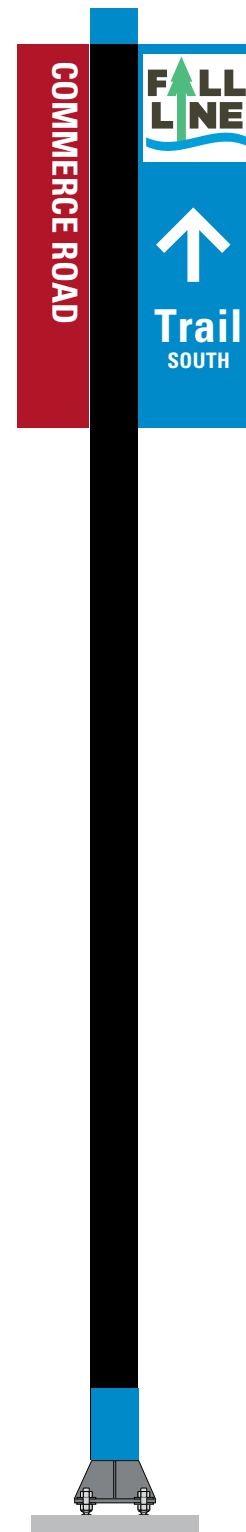

Sign Type U.41B  
Urban marker

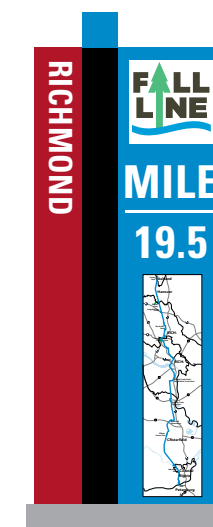

Sign Type M.19.5  
Mile Marker

THIS DRAWING REPRESENTS DESIGN INTENT ONLY.

Date 4.22.24	Revisions 6.6.24	Scale 3/4" = 1'
-----------------	---------------------	--------------------

Client/Project  
CVTA, Virginia  
Wayfinding for Fall Line Trail

**PROGRAMMING**  
Sign Location Plan  
Richmond

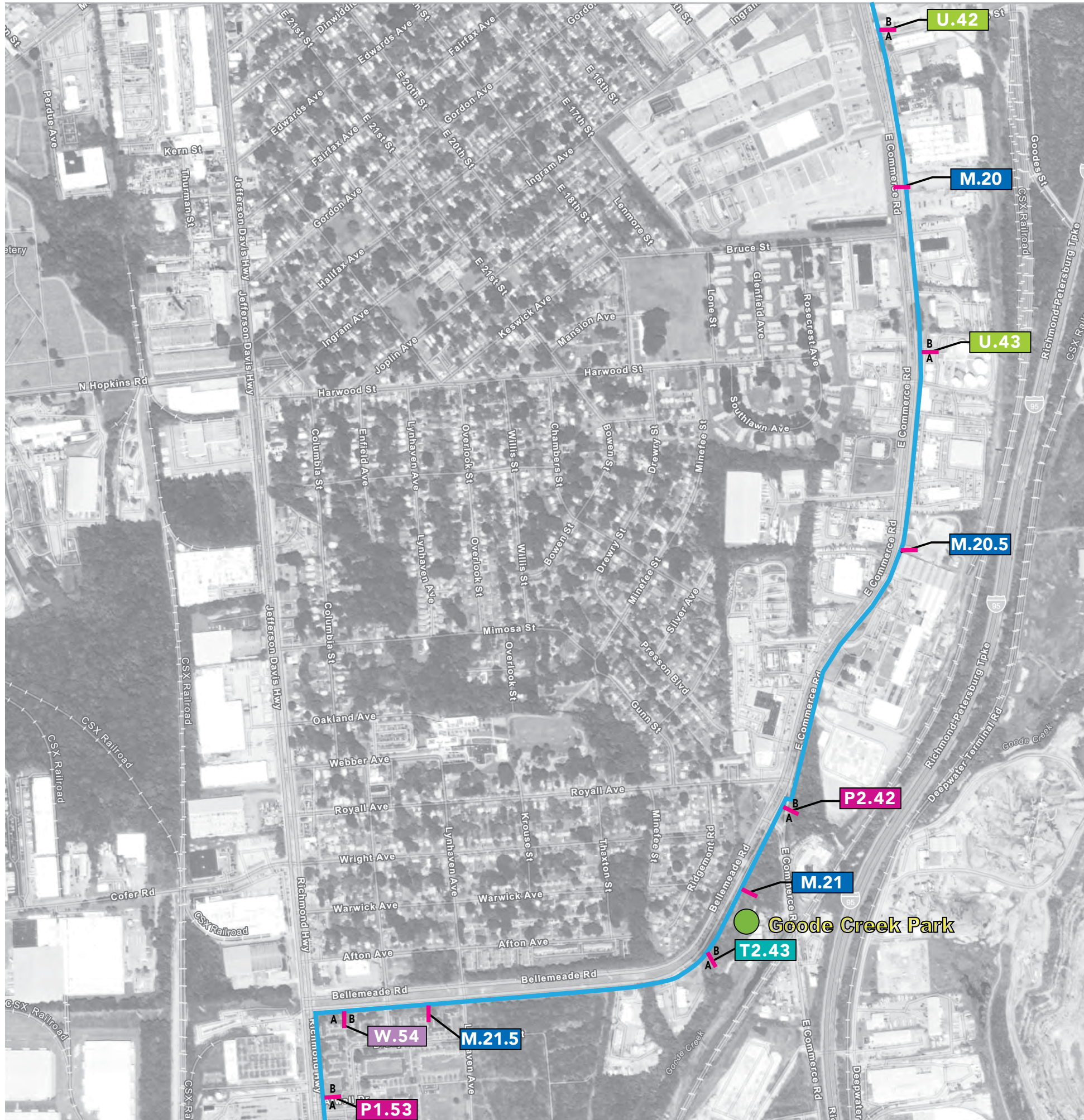

**SIGNTYPES KEY**

- ID Landmark Id.
- M Mile marker
- P Pedestrian Directional
- PL Plate
- T Trailhead Sign
- U Urban/ParkingMarker
- V Vehicular Directional
- W Directional
- Trail Access Point

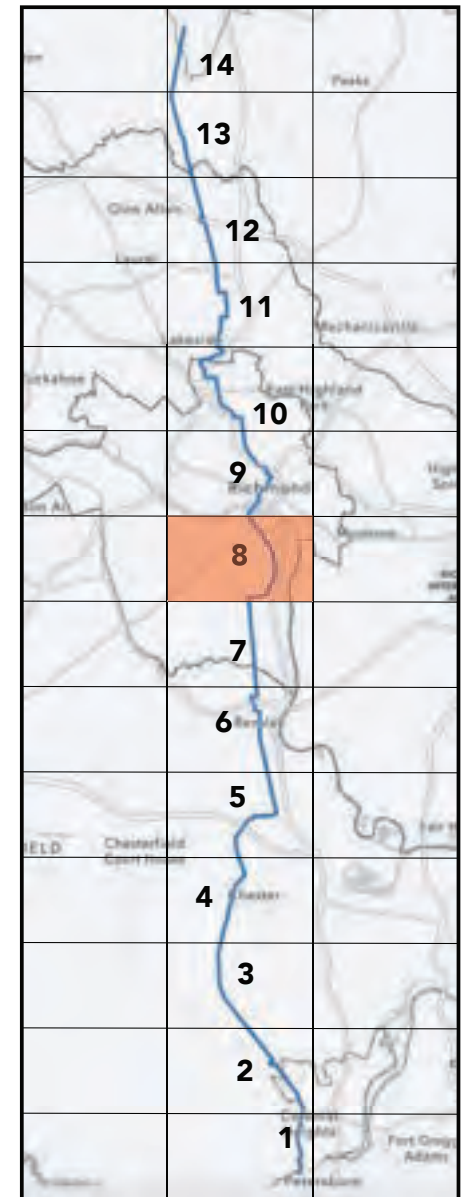

THIS DRAWING REPRESENTS DESIGN INTENT ONLY.

Date 4.22.24	Revisions 6.6.24	Scale NTS
-----------------	---------------------	--------------

Client/Project  
CVTA, Virginia  
Wayfinding for Fall Line Trail



**PROGRAMMING**  
**Sign Location Plan**  
**Richmond**

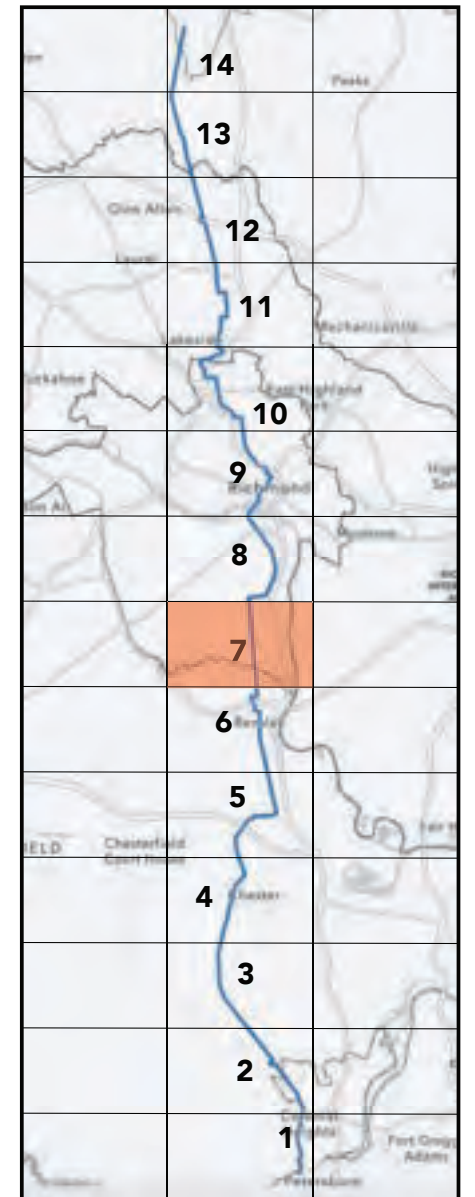

THIS DRAWING REPRESENTS DESIGN INTENT ONLY.

Date 4.22.24	Revisions 6.6.24	Scale NTS
-----------------	---------------------	--------------

Client/Project  
 CVTA, Virginia  
 Wayfinding for Fall Line Trail

© 2024 AB Design, Inc.

**R.19**

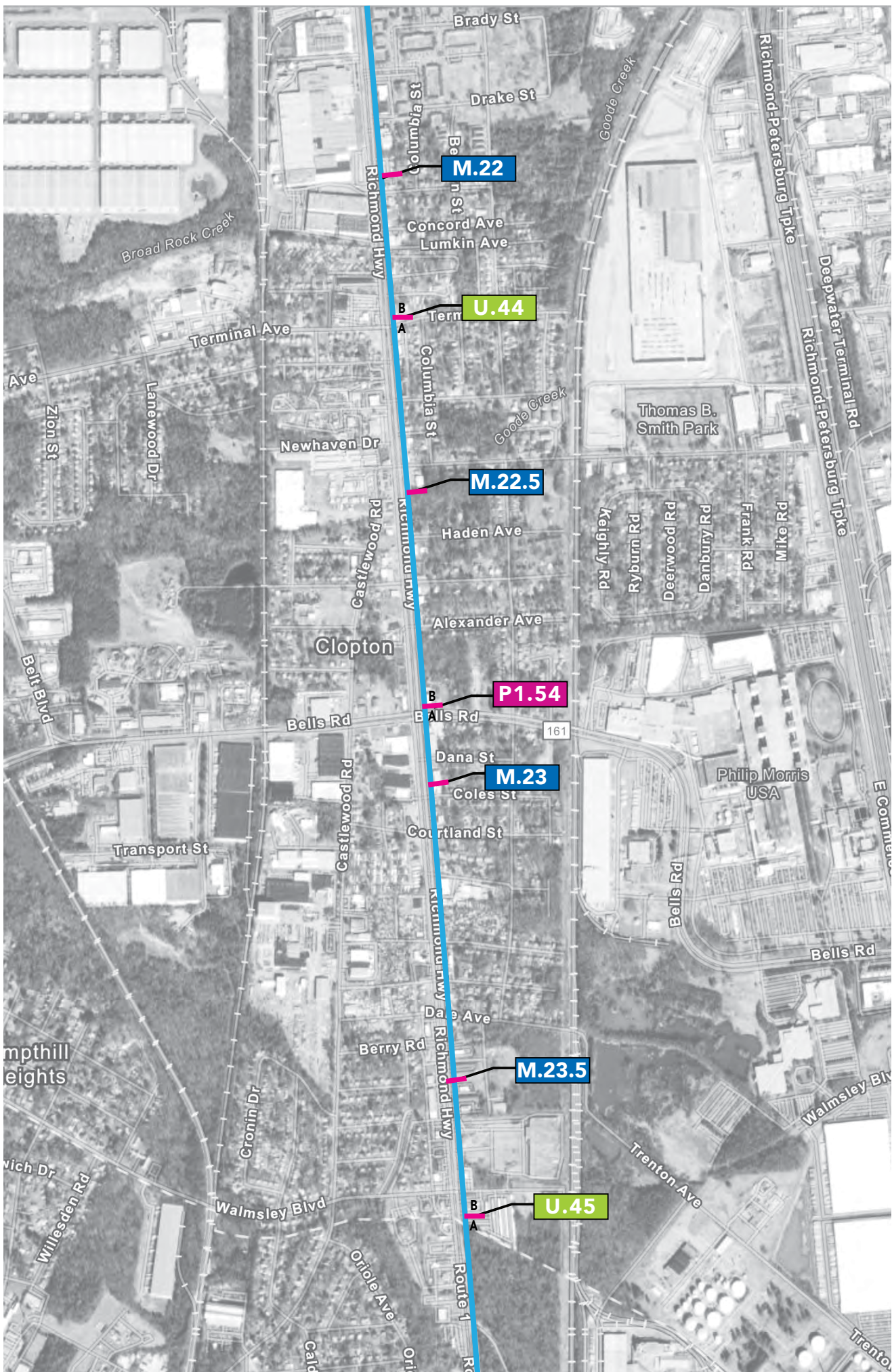

**SIGNTYPES KEY**

- ID Landmark Id.
- M Mile marker
- P Pedestrian Directional
- PL Plate
- T Trailhead Sign
- U Urban/ParkingMarker
- V Vehicular Directional
- W Directional
- Trail Access Point

We recommend the use of street pavers along Commerce Rd. to reinforce the route of the trail.

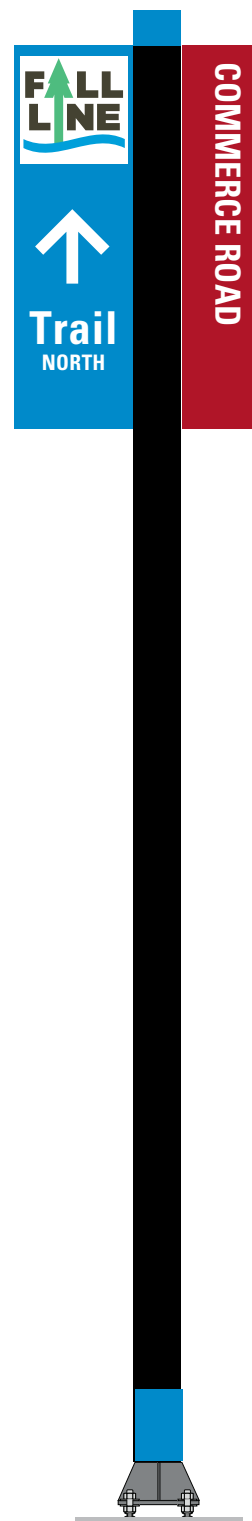

Sign Type U.42A  
Urban marker

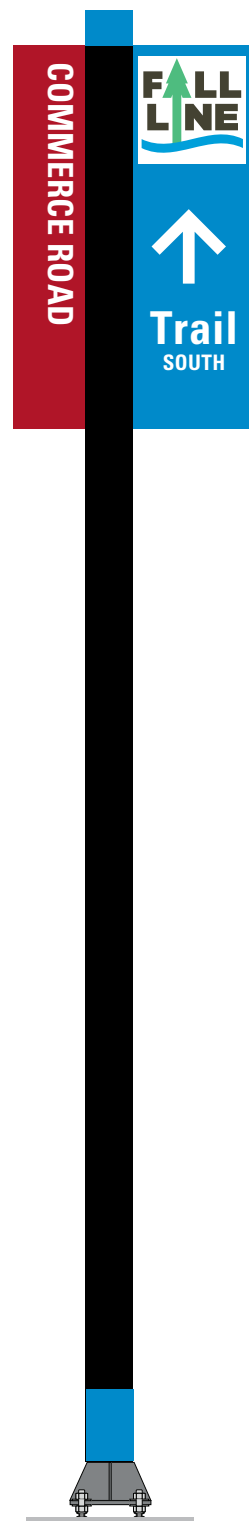

Sign Type U.42B  
Urban marker

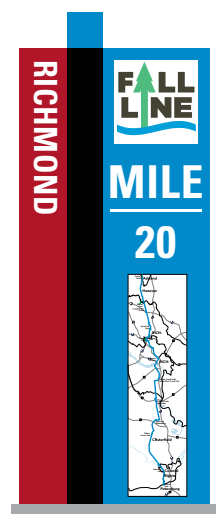

Sign Type M.20  
Mile Marker

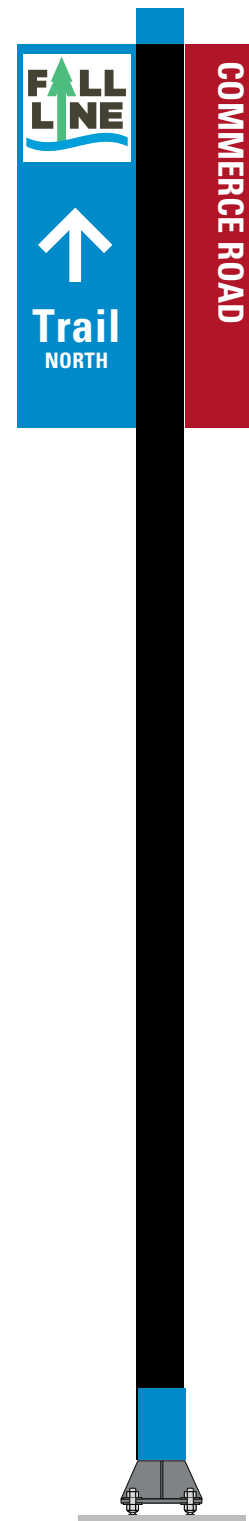

Sign Type U.43A  
Urban marker

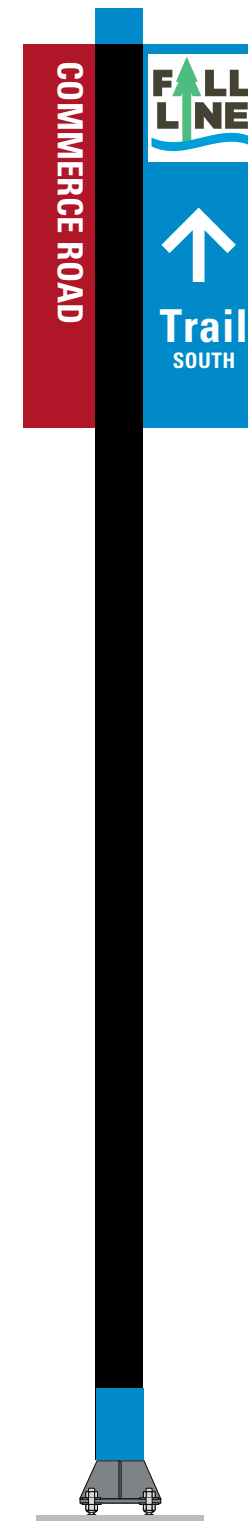

Sign Type U.43B  
Urban marker

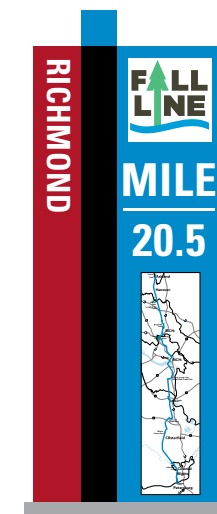

Sign Type M.20.5  
Mile Marker

PROGRAMMING

Sign Types  
Richmond

THIS DRAWING REPRESENTS DESIGN INTENT ONLY.

Date 4.22.24	Revisions 6.6.24	Scale 3/4"=1'
-----------------	---------------------	------------------

Client/Project  
CVTA, Virginia  
Wayfinding for Fall Line Trail

© 2024 AB Design, Inc.

**R.20**



We recommend the use of street pavers along Commerce Rd. to reinforce the route of the trail.

PROGRAMMING

Sign Types  
Richmond

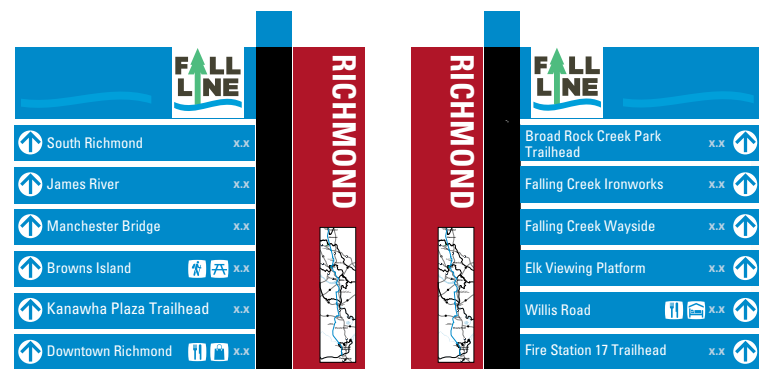

Sign Type P2.42A Pedestrian Directional

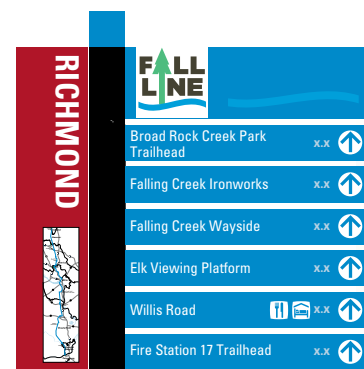

Sign Type P2.42B Pedestrian Directional

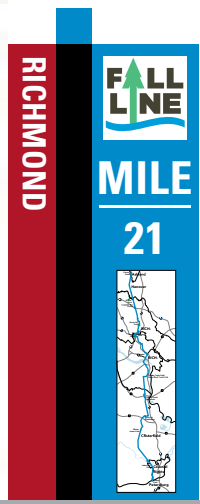

Sign Type M.21 Mile Marker



Sign Type T2.43A Pedestrian Trailhead/Regulatory Sign



Sign Type T2.43B Pedestrian Trailhead/Regulatory Sign

THIS DRAWING REPRESENTS DESIGN INTENT ONLY.

Date 12.4.23	Revisions 6.6.24	Scale 3/4" = 1'
-----------------	---------------------	--------------------

Client/Project  
CVTA, Virginia  
Wayfinding for Fall Line Trail

© 2024 AB Design, Inc.

We recommend the use of street pavers along Commerce Rd., Bellemeade Rd. and Richmond Highway to reinforce the route of the trail.

PROGRAMMING

Sign Types  
Richmond

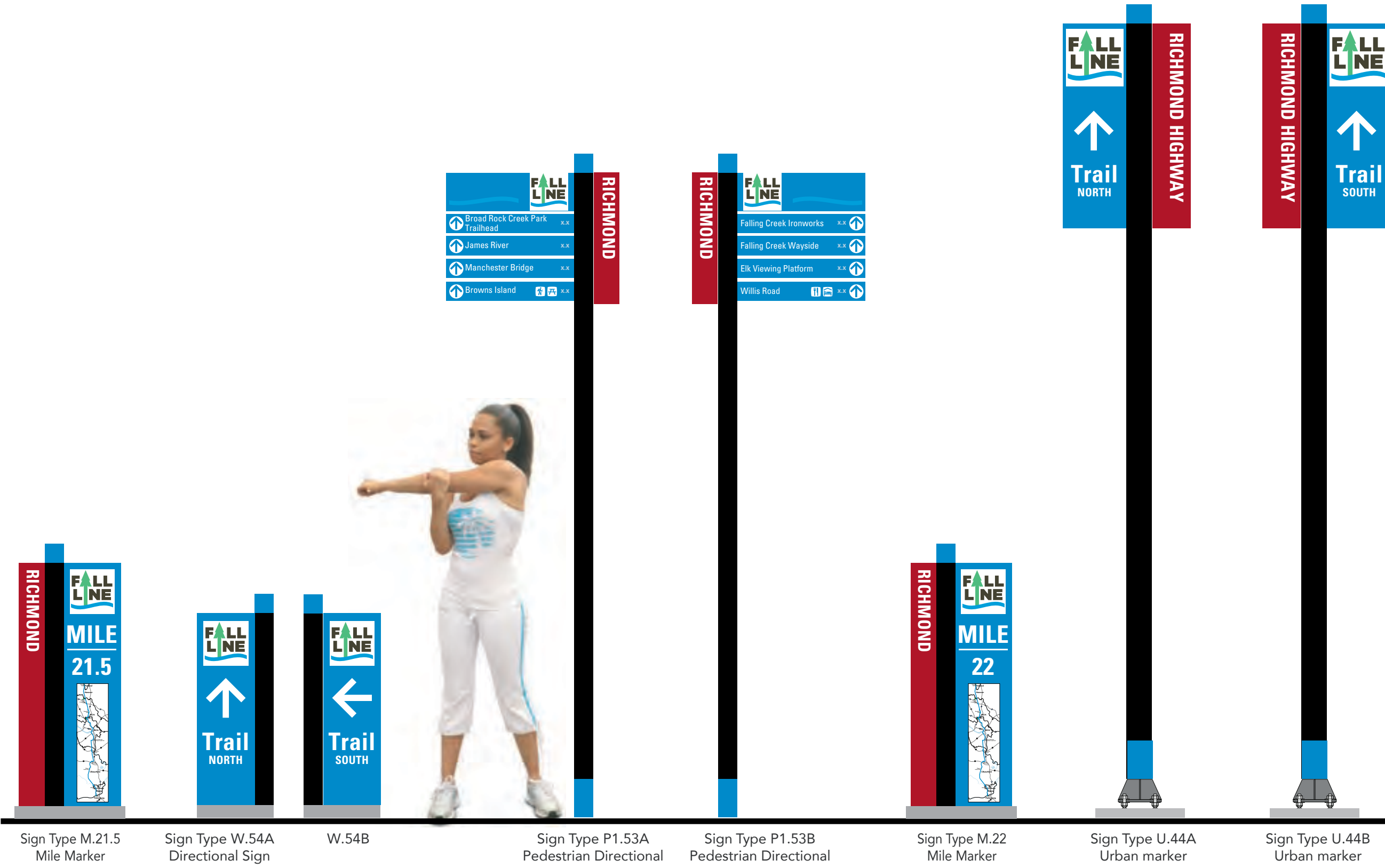

THIS DRAWING REPRESENTS DESIGN INTENT ONLY.

Date 4.22.24	Revisions 6.6.24	Scale 3/4" = 1'
-----------------	---------------------	--------------------

Client/Project  
CVTA, Virginia  
Wayfinding for Fall Line Trail

© 2024 AB Design, Inc.

We recommend the use of street pavers along Richmond Highway to reinforce the route of the trail.

PROGRAMMING

Sign Types  
Richmond

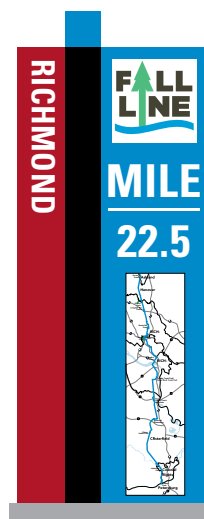
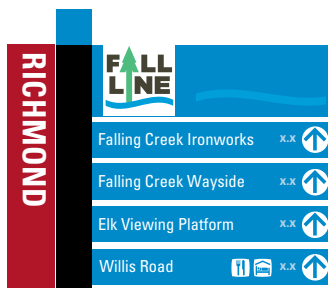

Sign Type M.22.5  
Mile Marker

Sign Type P1.54A  
Pedestrian Directional

Sign Type P1.54B  
Pedestrian Directional

Sign Type M.23  
Mile Marker

Sign Type M.23.5  
Mile Marker

Sign Type U.45A  
Urban marker

Sign Type U.45B  
Urban marker

THIS DRAWING REPRESENTS DESIGN INTENT ONLY.

Date 4.22.24	Revisions 6.6.24	Scale 3/4" = 1'
-----------------	---------------------	--------------------

Client/Project  
CVTA, Virginia  
Wayfinding for Fall Line Trail

© 2024 AB Design, Inc.

June 2024



# CVTA Wayfinding for Fall Line Trail

Programming  
Chesterfield County



1005 Stonemill Road  
Richmond, Virginia 23233  
Phone: 804-346-4771  
Fax: 804-325-1751  
[www.abdesignonline.com](http://www.abdesignonline.com)



**PROGRAMMING**  
Sign Location Plan  
Chesterfield

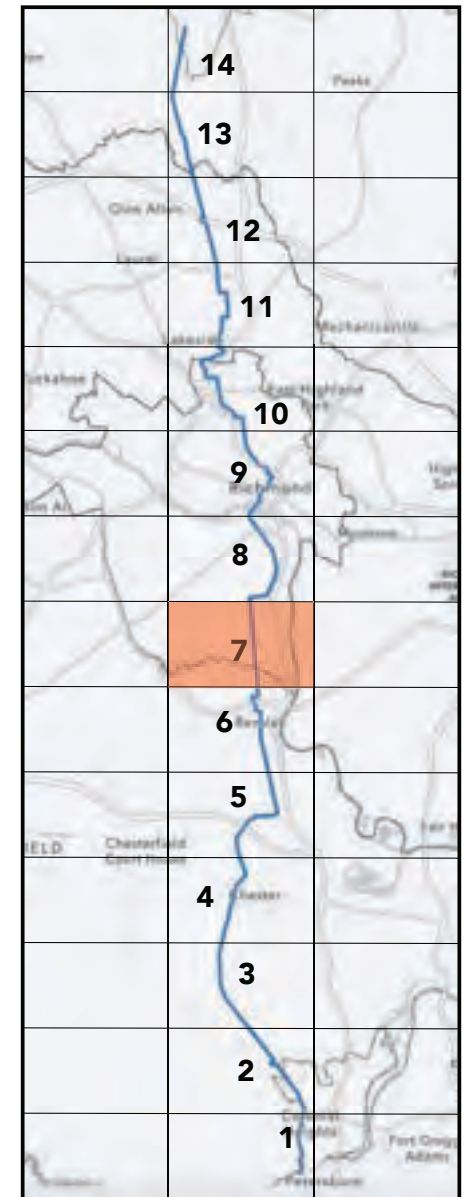

THIS DRAWING REPRESENTS DESIGN INTENT ONLY.

Date	Revisions	Scale
4.25.24	6.10.24	NTS
	6.26.24	

Client/Project  
CVTA, Virginia  
Wayfinding for Fall Line Trail

© 2024 AB Design, Inc.

**CH.1**



**SIGNTYPES KEY**

- ID Landmark Id.
- M Mile marker
- P Pedestrian Directional
- PL Plate
- T Trailhead Sign
- U Urban/ParkingMarker
- V Vehicular Directional
- W Directional
- Trail Access Point



**PROGRAMMING**  
Sign Location Plan  
Chesterfield

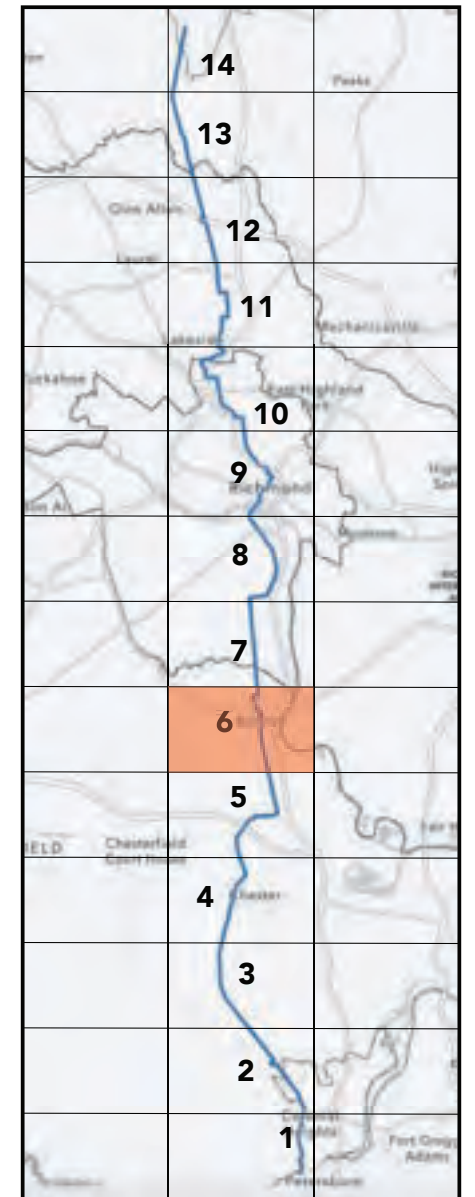

THIS DRAWING REPRESENTS DESIGN INTENT ONLY.

Date 4.25.24	Revisions 5.16.24 6.10.24 6.26.24	Scale NTS
-----------------	--	--------------

Client/Project  
CVTA, Virginia  
Wayfinding for Fall Line Trail

© 2024 AB Design, Inc.

**CH.2**

**SIGNTYPES KEY**

- ID Landmark Id.
- M Mile marker
- P Pedestrian Directional
- PL Plate
- T Trailhead Sign
- U Urban/ParkingMarker
- V Vehicular Directional
- W Directional
- Trail Access Point

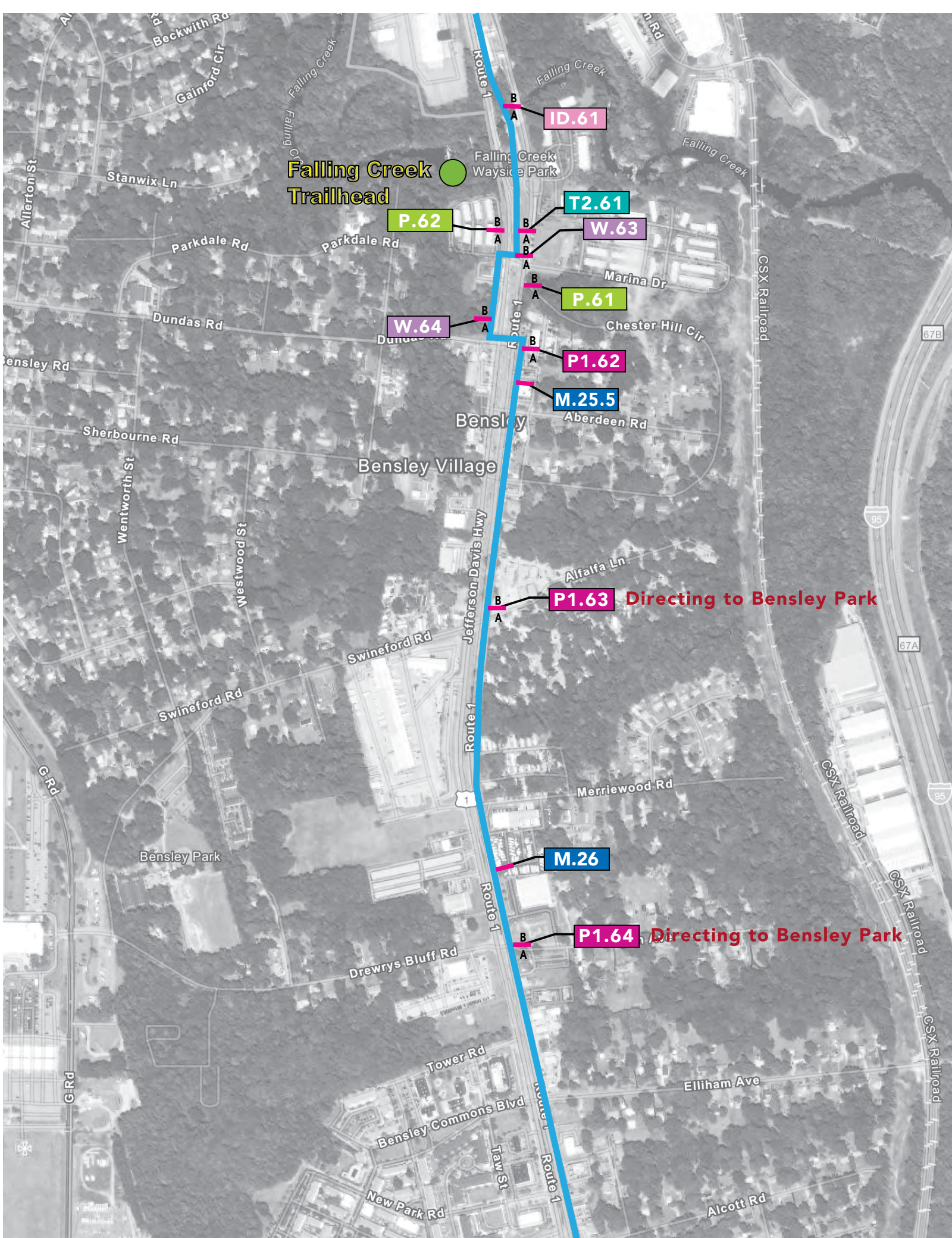

PROGRAMMING

Sign Types  
Chesterfield



Sign Type P2.61A Pedestrian Directional  
Sign Type P2.61B Pedestrian Directional

Sign Type M.24 Mile Marker

Sign Type W.61A Directional Sign

W.61B

Sign Type M.24.5 Mile Marker

Sign Type W.62A Directional Sign

W.621B

THIS DRAWING REPRESENTS DESIGN INTENT ONLY.

Date 4.25.24	Revisions 6.10.24 6.26.24	Scale 3/4" = 1'
-----------------	---------------------------------	--------------------

Client/Project  
CVTA, Virginia  
Wayfinding for Fall Line Trail

© 2024 AB Design, Inc.

PROGRAMMING

Sign Types  
Chesterfield



Sign Type P1.61A Pedestrian Directional Sign Type P1.61B Pedestrian Directional

Sign Type M.25 Mile Marker

Sign Type P2.62A Pedestrian Directional Sign Type P2.62B Pedestrian Directional

Sign Type ID.61A Landmark Identification

Sign Type ID.61B Landmark Identification

THIS DRAWING REPRESENTS DESIGN INTENT ONLY.

Date	Revisions	Scale
4.25.24	6.10.24 6.26.24	3/4" = 1'

Client/Project  
CVTA, Virginia  
Wayfinding for Fall Line Trail

© 2024 AB Design, Inc.



PROGRAMMING

Sign Types  
Chesterfield



Sign Type T2.61A  
Pedestrian TrailRad/  
Regulatory Sign

Sign Type T2.61B  
Pedestrian TrailRad/  
Regulatory Sign



Sign Type P.61A  
Urban marker

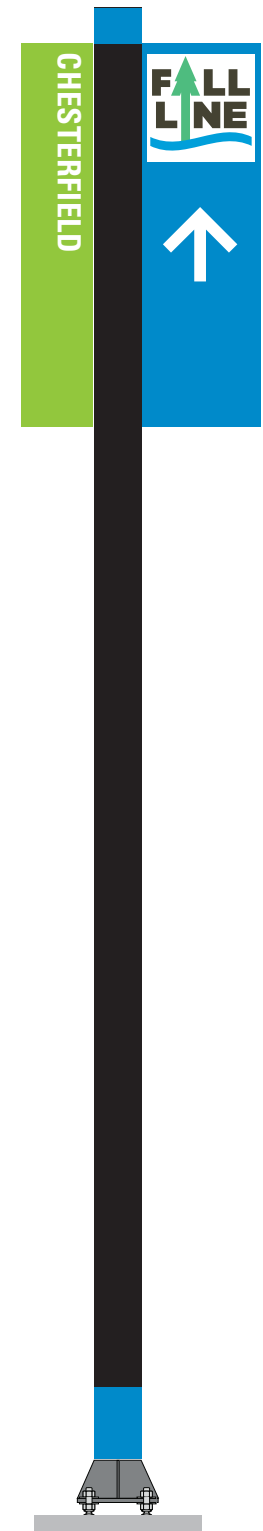

Sign Type P.61B  
Urban marker

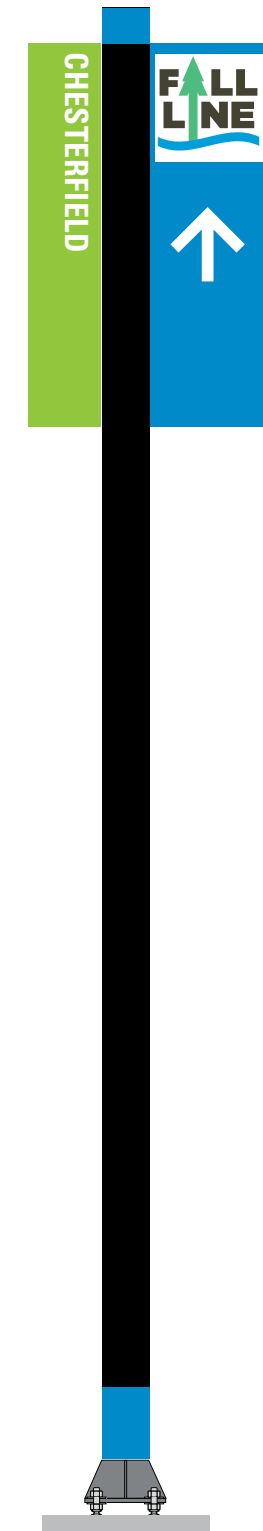

Sign Type P.62B  
Urban marker

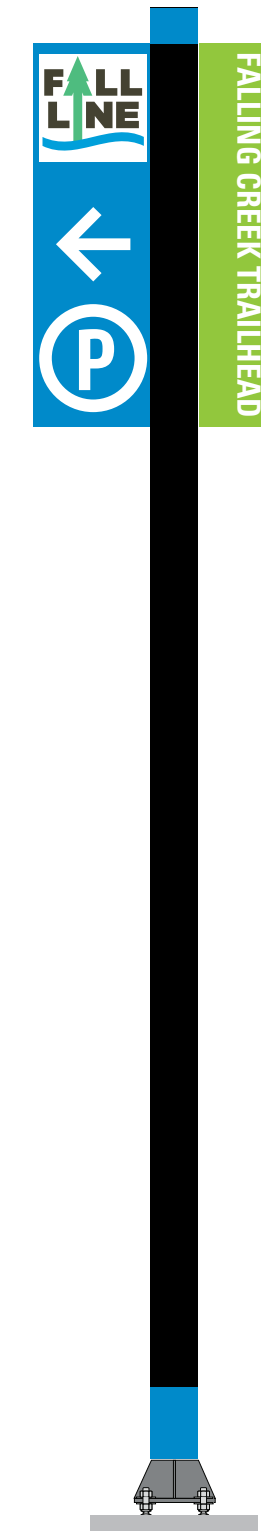

Sign Type P.62A  
Urban marker

THIS DRAWING REPRESENTS DESIGN INTENT ONLY.

Date	Revisions	Scale
4.25.24	5.16.24 6.10.24 6.26.24	3/4" = 1'

Client/Project  
CVTA, Virginia  
Wayfinding for Fall Line Trail

© 2024 AB Design, Inc.

PROGRAMMING

Sign Types  
Chesterfield

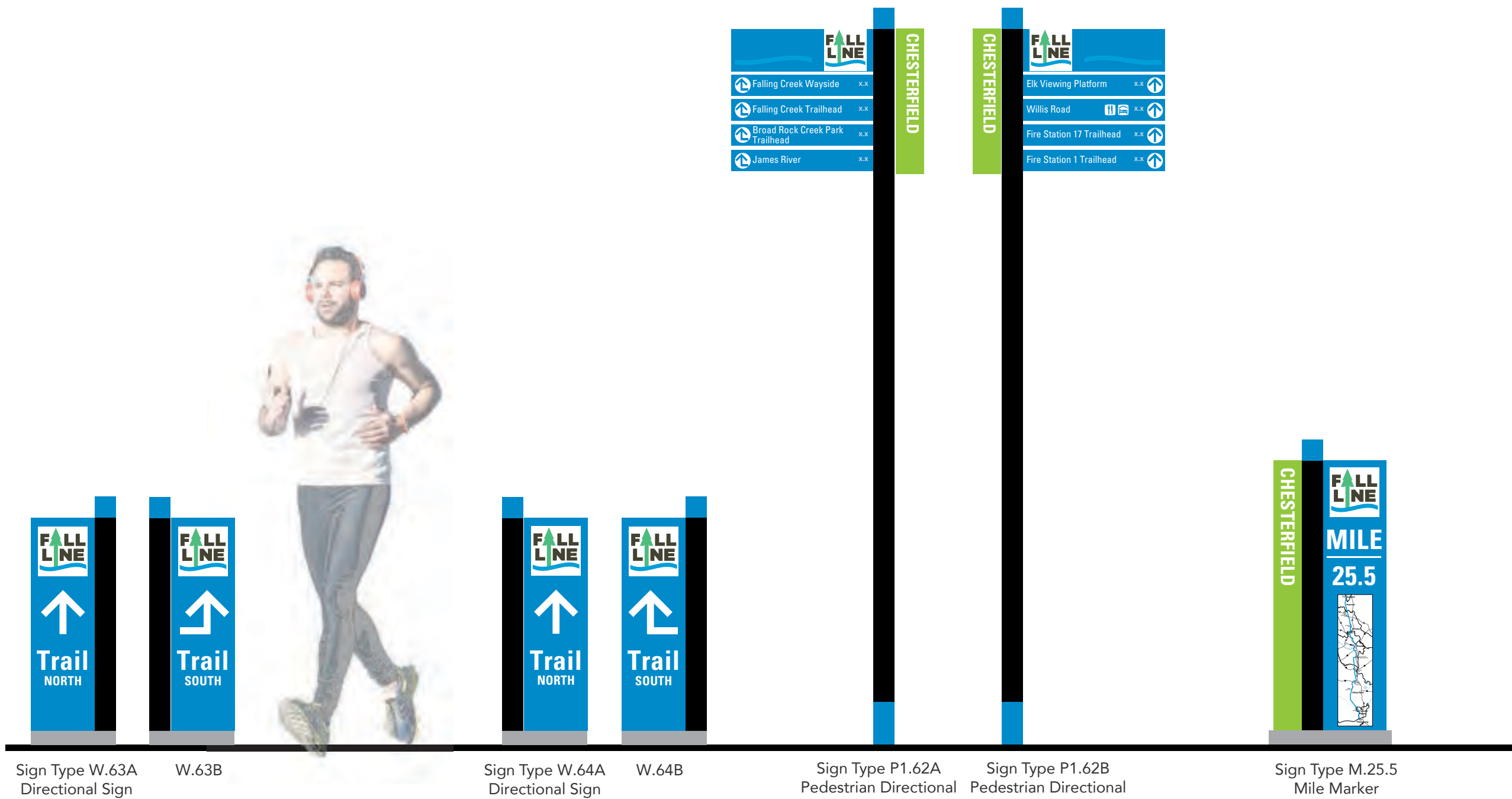

Sign Type W.63A  
Directional Sign

W.63B

Sign Type W.64A  
Directional Sign

W.64B

Sign Type P1.62A  
Pedestrian Directional

Sign Type P1.62B  
Pedestrian Directional

Sign Type M.25.5  
Mile Marker

THIS DRAWING REPRESENTS DESIGN INTENT ONLY.

Date 4.25.24	Revisions 6.10.24 6.26.24	Scale 3/4" = 1'
-----------------	---------------------------------	--------------------

Client/Project  
CVTA, Virginia  
Wayfinding for Fall Line Trail

© 2024 AB Design, Inc.

PROGRAMMING

Sign Types  
Chesterfield



Sign Type P1.63A Pedestrian Directional  
Sign Type P1.63B Pedestrian Directional

Sign Type M.26 Mile Marker

Sign Type P1.64A Pedestrian Directional  
Sign Type P1.64B Pedestrian Directional

THIS DRAWING REPRESENTS DESIGN INTENT ONLY.

Date	Revisions	Scale
4.25.24	5.16.24 6.10.24 6.26.24	3/4" = 1'

Client/Project  
CVTA, Virginia  
Wayfinding for Fall Line Trail



**PROGRAMMING**  
Sign Location Plan  
Chesterfield

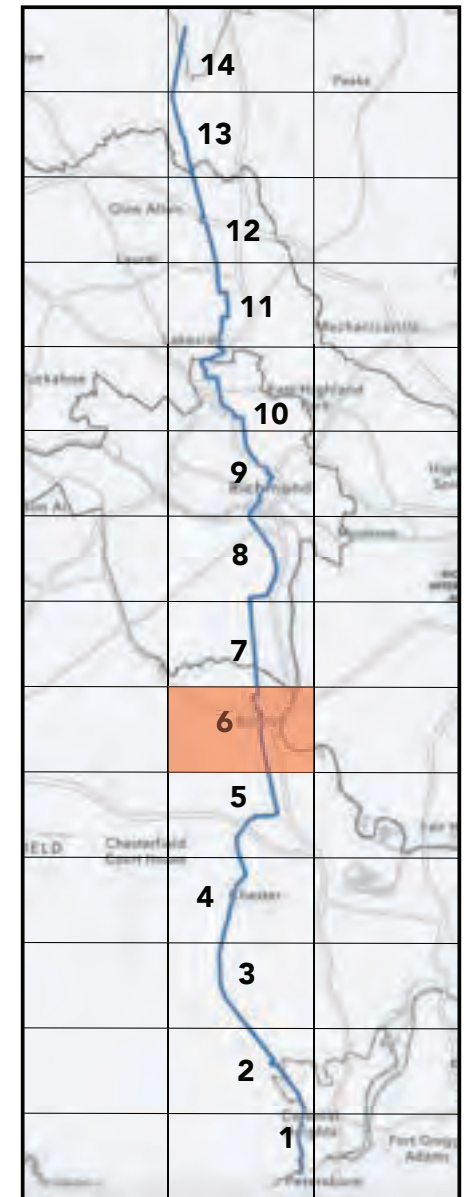

**SIGNTYPES KEY**

ID	Landmark Id.
M	Mile marker
P	Pedestrian Directional
PL	Plate
T	Trailhead Sign
U	Urban/ParkingMarker
V	Vehicular Directional
W	Directional
●	Trail Access Point

THIS DRAWING REPRESENTS DESIGN INTENT ONLY.

Date 4.29.24	Revisions 6.10.24 6.26.24	Scale NTS
-----------------	---------------------------------	--------------

Client/Project  
CVTA, Virginia  
Wayfinding for Fall Line Trail

© 2024 AB Design, Inc.

**CH.8**

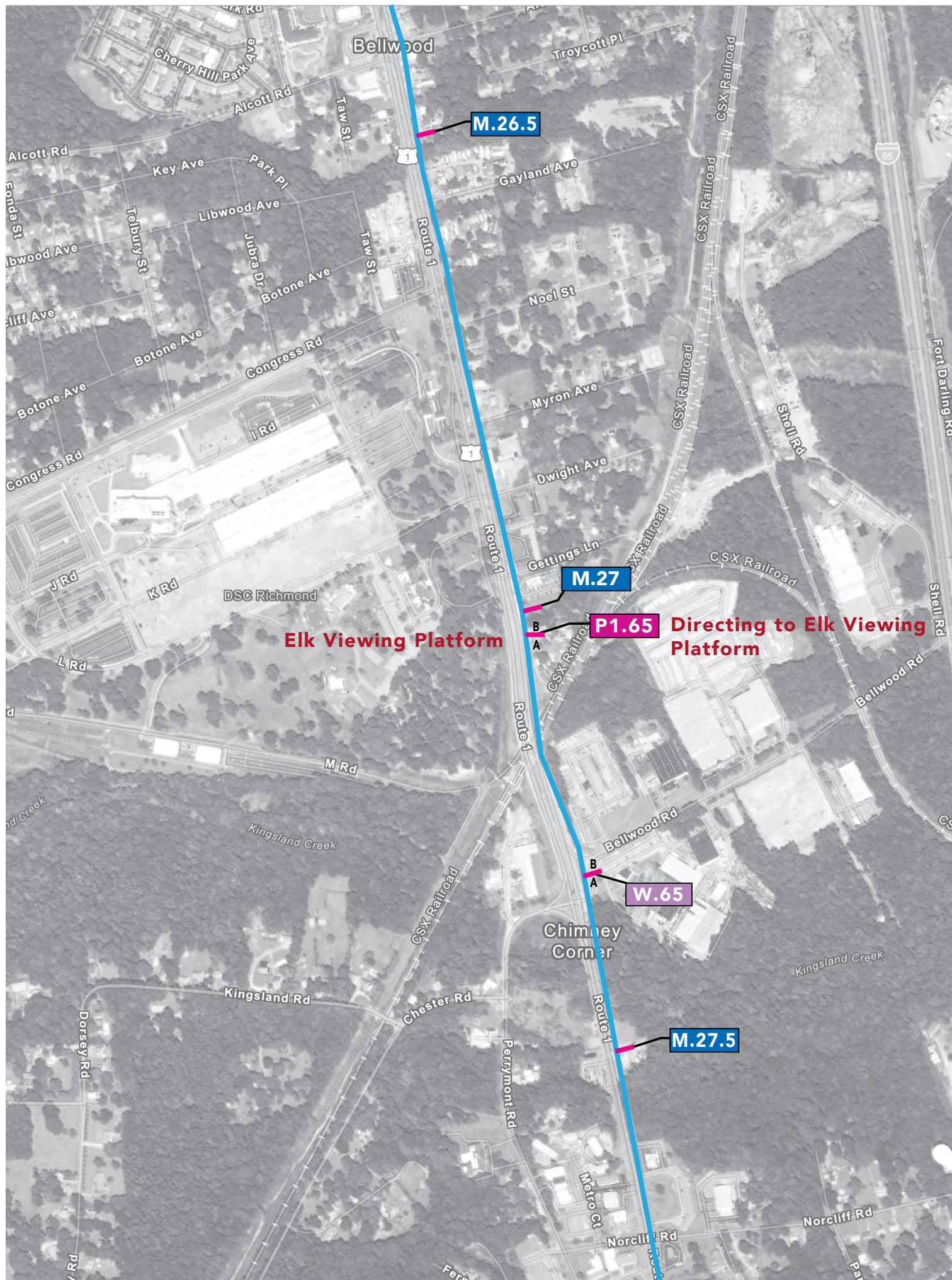



**PROGRAMMING**  
Sign Location Plan  
Chesterfield

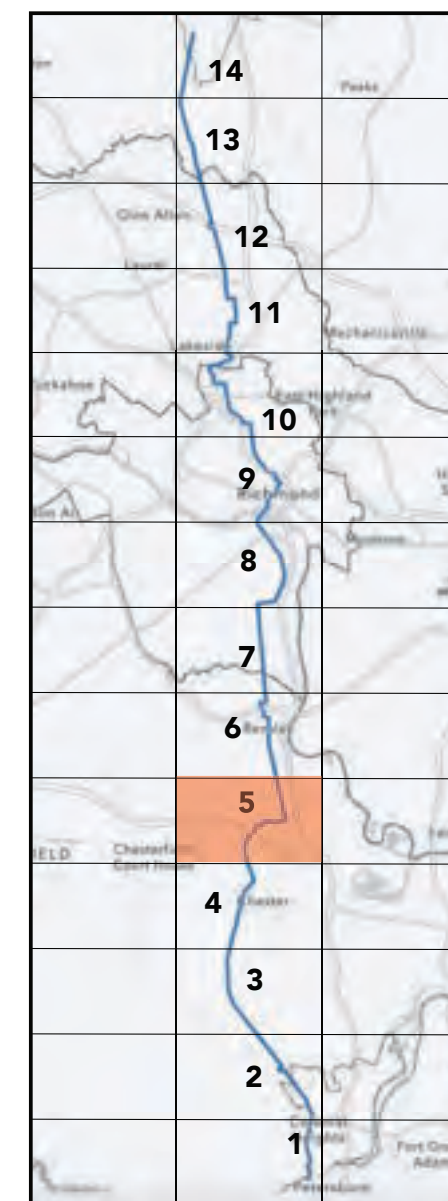

THIS DRAWING REPRESENTS DESIGN INTENT ONLY.

Date 4.29.24	Revisions 6.10.24 6.26.24	Scale NTS
-----------------	---------------------------------	--------------

Client/Project  
CVTA, Virginia  
Wayfinding for Fall Line Trail

© 2024 AB Design, Inc.

**CH.9**

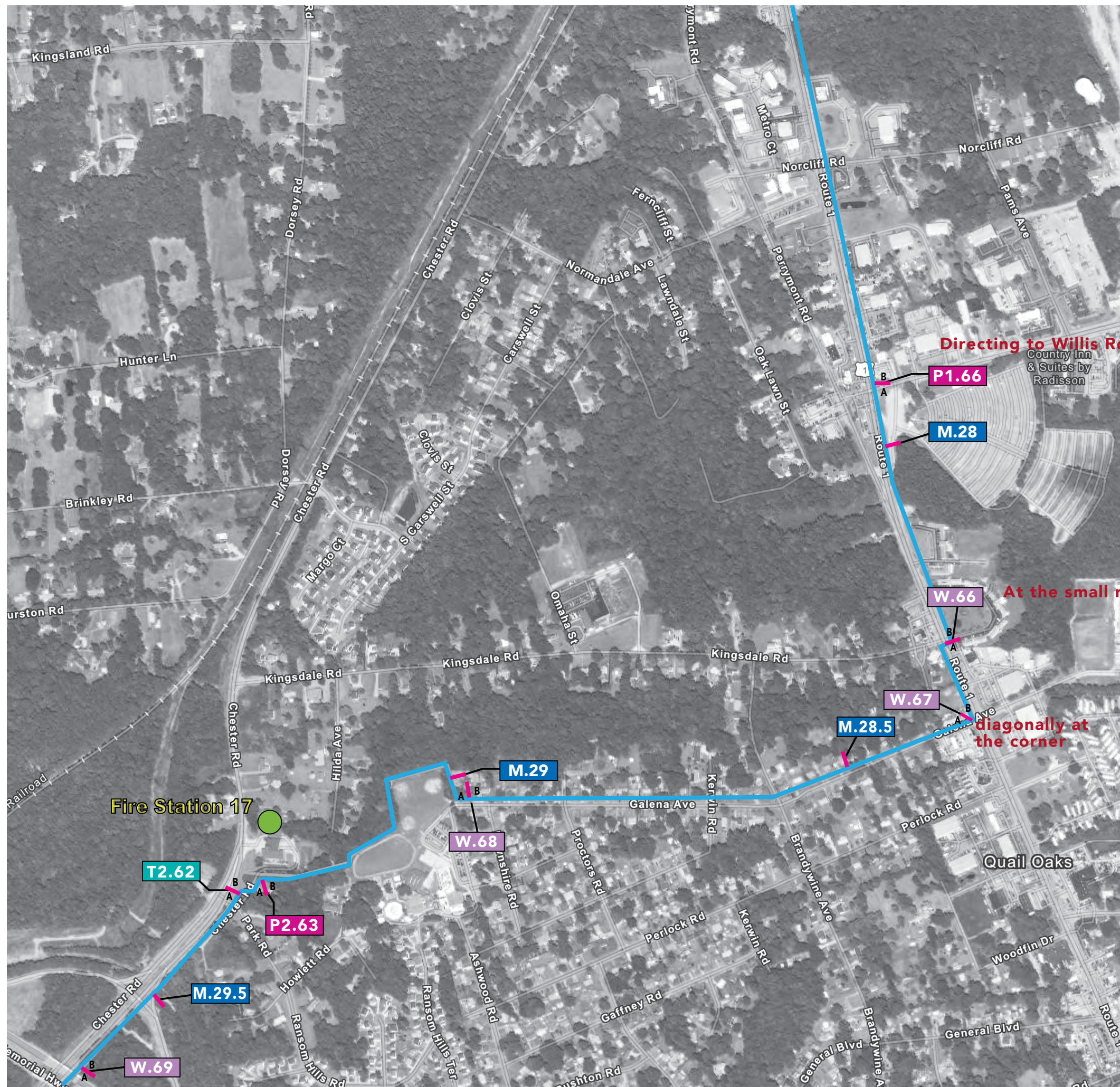

**SIGNTYPES KEY**

- ID Landmark Id.
- M Mile marker
- P Pedestrian Directional
- PL Plate
- T Trailhead Sign
- U Urban/ParkingMarker
- V Vehicular Directional
- W Directional
- Trail Access Point

PROGRAMMING

Sign Types  
Chesterfield

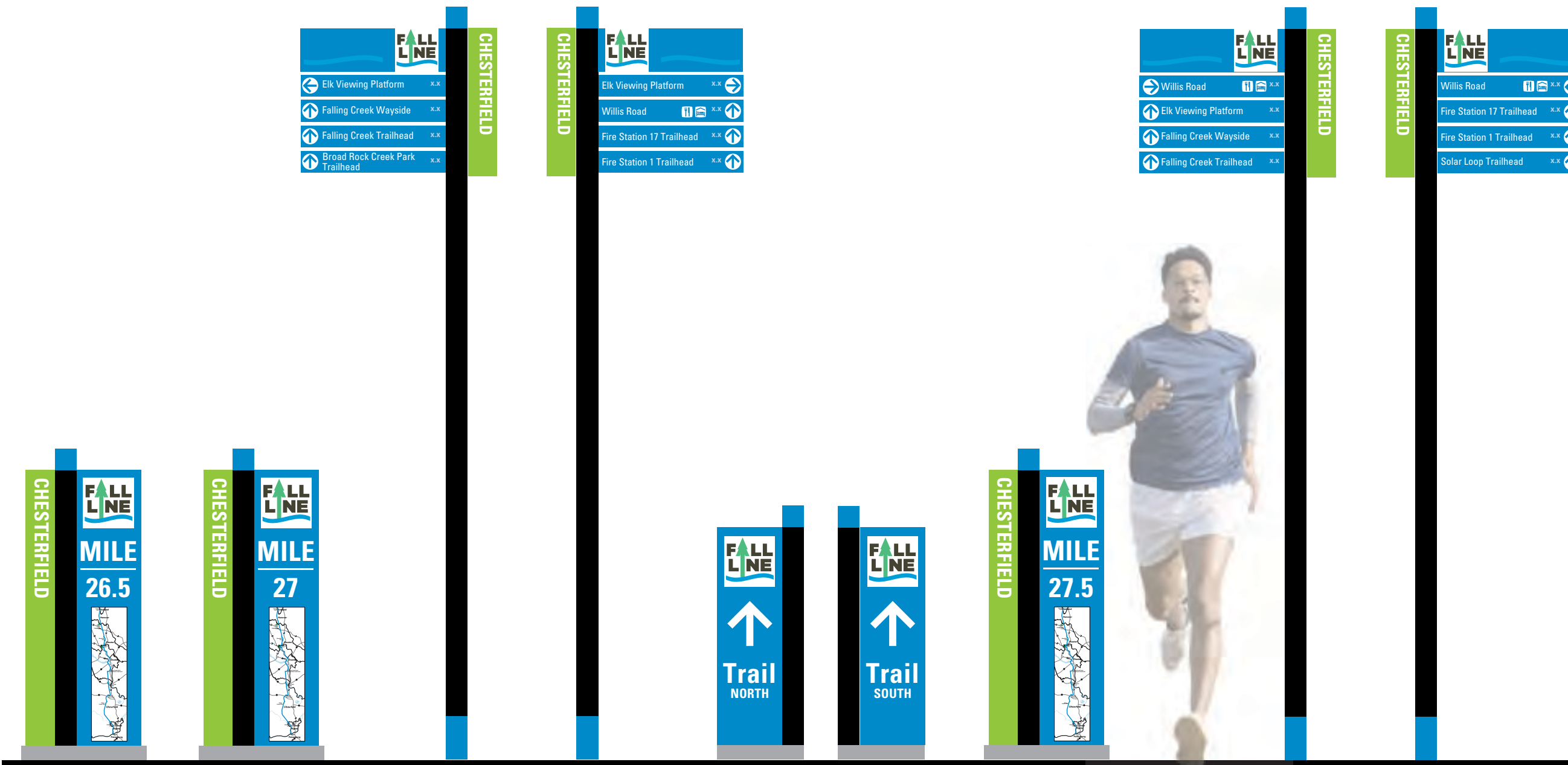

Sign Type M.26.5  
Mile Marker

Sign Type M.27  
Mile Marker

Sign Type P1.65A  
Pedestrian Directional

Sign Type P1.65B  
Pedestrian Directional

Sign Type W.65A  
W.65B  
Directional Sign

Sign Type M.27.5  
Mile Marker

Sign Type P1.66A  
Pedestrian Directional

Sign Type P1.66B  
Pedestrian Directional

THIS DRAWING REPRESENTS DESIGN INTENT ONLY.

Date	Revisions	Scale
4.29.24	6.10.24 6.26.24	3/4" = 1'

Client/Project  
CVTA, Virginia  
Wayfinding for Fall Line Trail

© 2024 AB Design, Inc.

PROGRAMMING

Sign Types  
Chesterfield

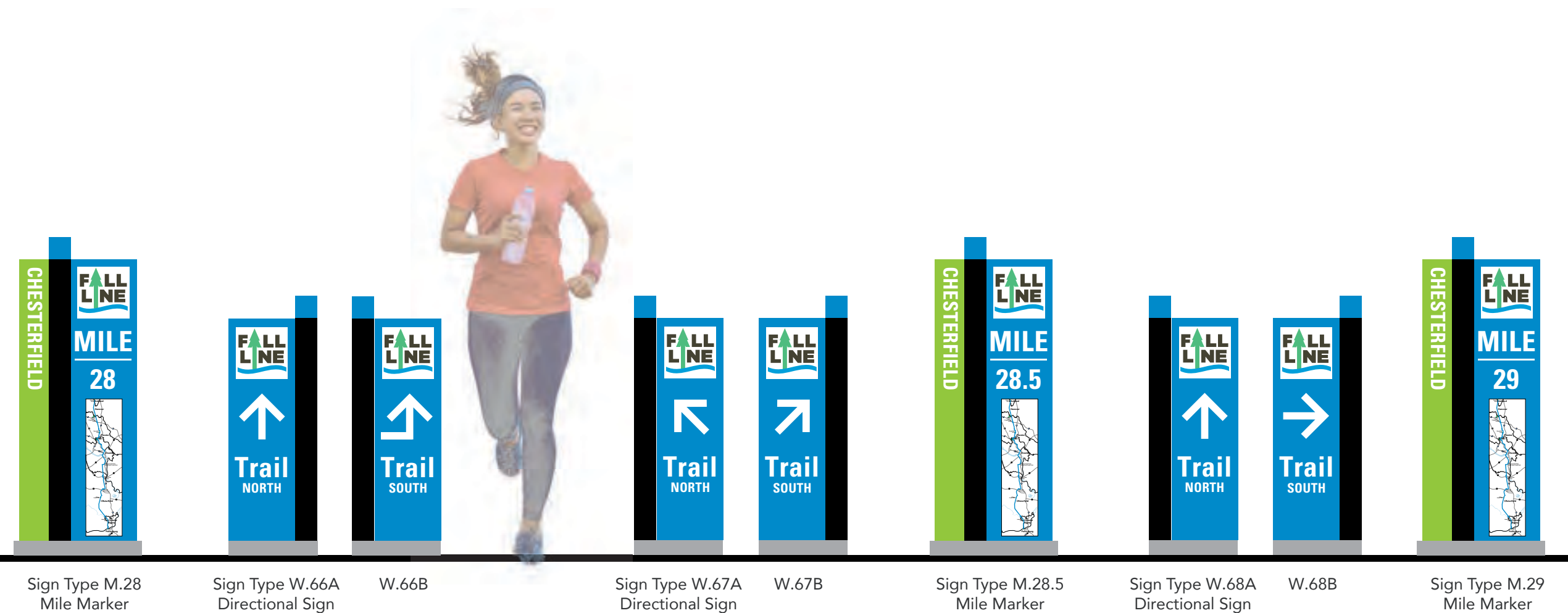

Sign Type M.28  
Mile Marker

Sign Type W.66A  
Directional Sign

W.66B

Sign Type W.67A  
Directional Sign

W.67B

Sign Type M.28.5  
Mile Marker

Sign Type W.68A  
Directional Sign

W.68B

Sign Type M.29  
Mile Marker

THIS DRAWING REPRESENTS DESIGN INTENT ONLY.

Date	Revisions	Scale
4.29.24	6.10.24 6.26.24	3/4" = 1'

Client/Project  
CVTA, Virginia  
Wayfinding for Fall Line Trail

© 2024 AB Design, Inc.

PROGRAMMING

Sign Types  
Chesterfield



Sign Type P2.63A Pedestrian Directional  
Sign Type P2.63B Pedestrian Directional

Sign Type T2.62A Pedestrian TrailRad/  
Regulatory Sign

Sign Type T2.62B Pedestrian TrailRad/  
Regulatory Sign

Sign Type M.29.5 Mile Marker

Sign Type W.69A Directional Sign

W.69B

THIS DRAWING REPRESENTS DESIGN INTENT ONLY.

Date 4.29.24	Revisions 6.10.24 6.26.24	Scale 3/4" = 1'
-----------------	---------------------------------	--------------------

Client/Project  
CVTA, Virginia  
Wayfinding for Fall Line Trail

© 2024 AB Design, Inc.





**PROGRAMMING**  
**Sign Location Plan**  
**Chesterfield**

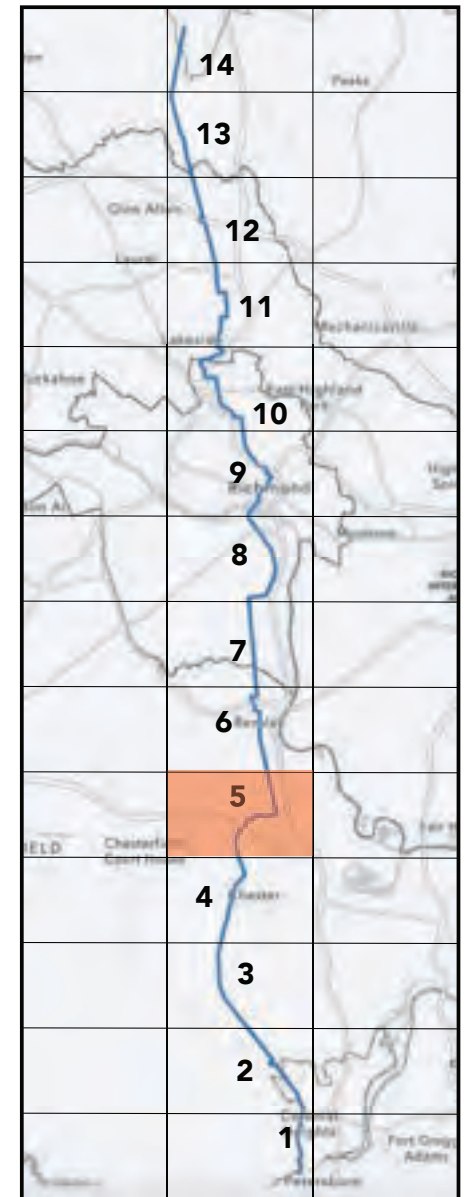

THIS DRAWING REPRESENTS DESIGN INTENT ONLY.

Date 4.29.24	Revisions 6.10.24 6.26.24	Scale NTS
-----------------	---------------------------------	--------------

Client/Project  
 CVTA, Virginia  
 Wayfinding for Fall Line Trail

© 2024 AB Design, Inc.

**CH.13**

**SIGNTYPES KEY**

- ID Landmark Id.
- M Mile marker
- P Pedestrian Directional
- PL Plate
- T Trailhead Sign
- U Urban/ParkingMarker
- V Vehicular Directional
- W Directional
- Trail Access Point





**PROGRAMMING**  
Sign Location Plan  
Chesterfield

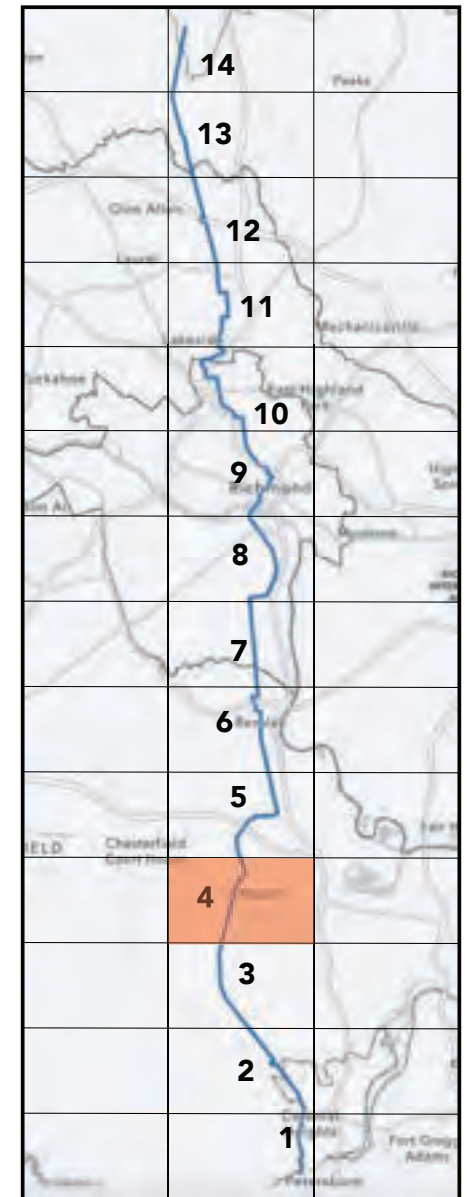

THIS DRAWING REPRESENTS DESIGN INTENT ONLY.

Date 4.29.24	Revisions 6.10.24 6.26.24	Scale NTS
-----------------	---------------------------------	--------------

Client/Project  
CVTA, Virginia  
Wayfinding for Fall Line Trail

© 2024 AB Design, Inc.

**CH.14**

**SIGNTYPES KEY**

- ID Landmark Id.
- M Mile marker
- P Pedestrian Directional
- PL Plate
- T Trailhead Sign
- U Urban/ParkingMarker
- V Vehicular Directional
- W Directional
- Trail Access Point

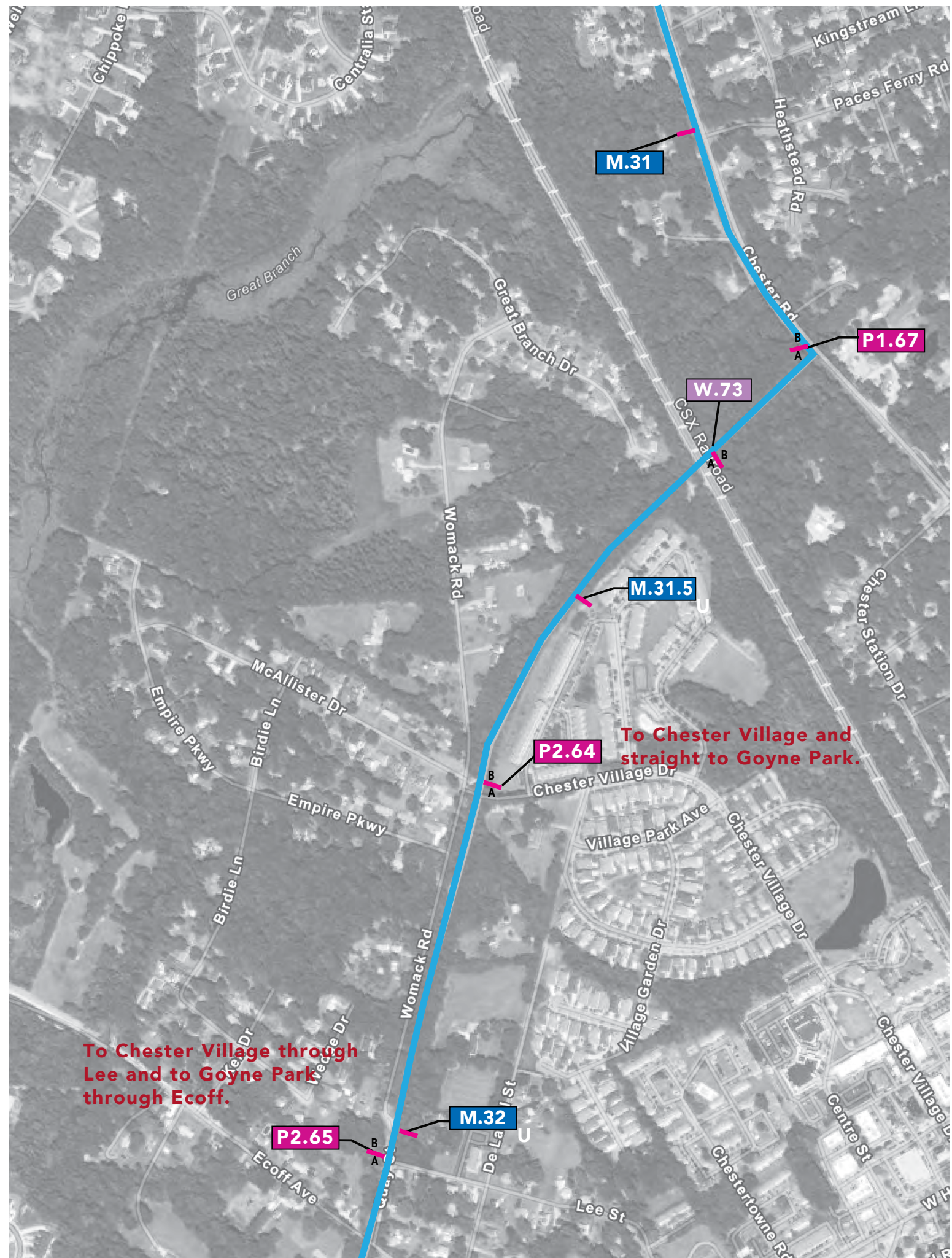

PROGRAMMING

Sign Types  
Chesterfield

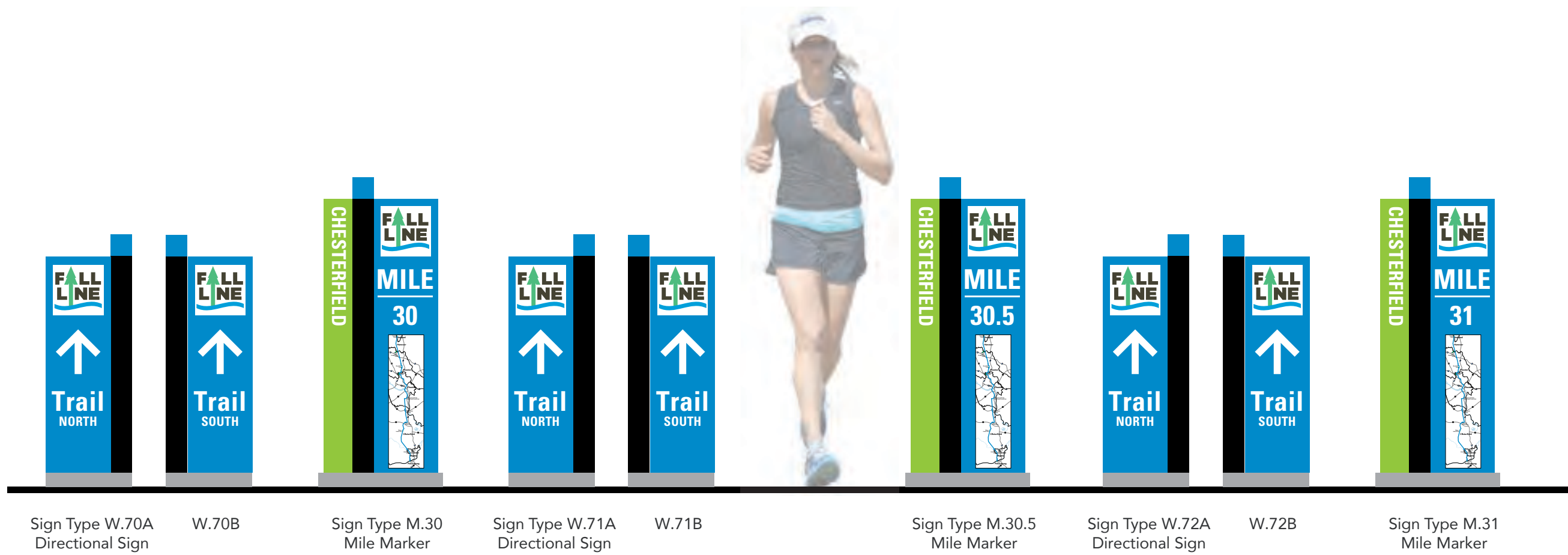

THIS DRAWING REPRESENTS DESIGN INTENT ONLY.

Date 4.29.24	Revisions 6.10.24 6.26.24	Scale 3/4"=1'
-----------------	---------------------------------	------------------

Client/Project  
CVTA, Virginia  
Wayfinding for Fall Line Trail

© 2024 AB Design, Inc.

PROGRAMMING

Sign Types  
Chesterfield

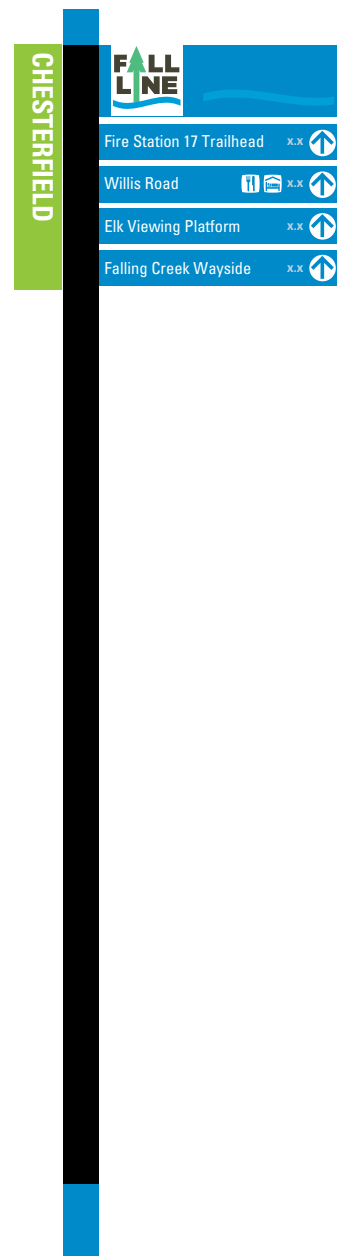

Sign Type P1.67A  
Pedestrian Directional

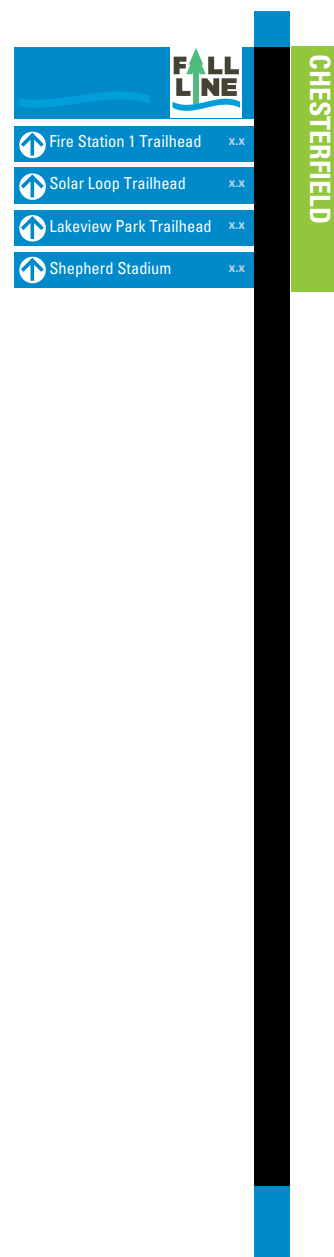

Sign Type P1.67B  
Pedestrian Directional



Sign Type W.73A  
Directional Sign

W.73B



Sign Type M.32  
Mile Marker

THIS DRAWING REPRESENTS DESIGN INTENT ONLY.

Date	Revisions	Scale
4.29.24	6.10.24 6.26.24	3/4" = 1'

Client/Project  
CVTA, Virginia  
Wayfinding for Fall Line Trail

© 2024 AB Design, Inc.

PROGRAMMING

Sign Types  
Chesterfield

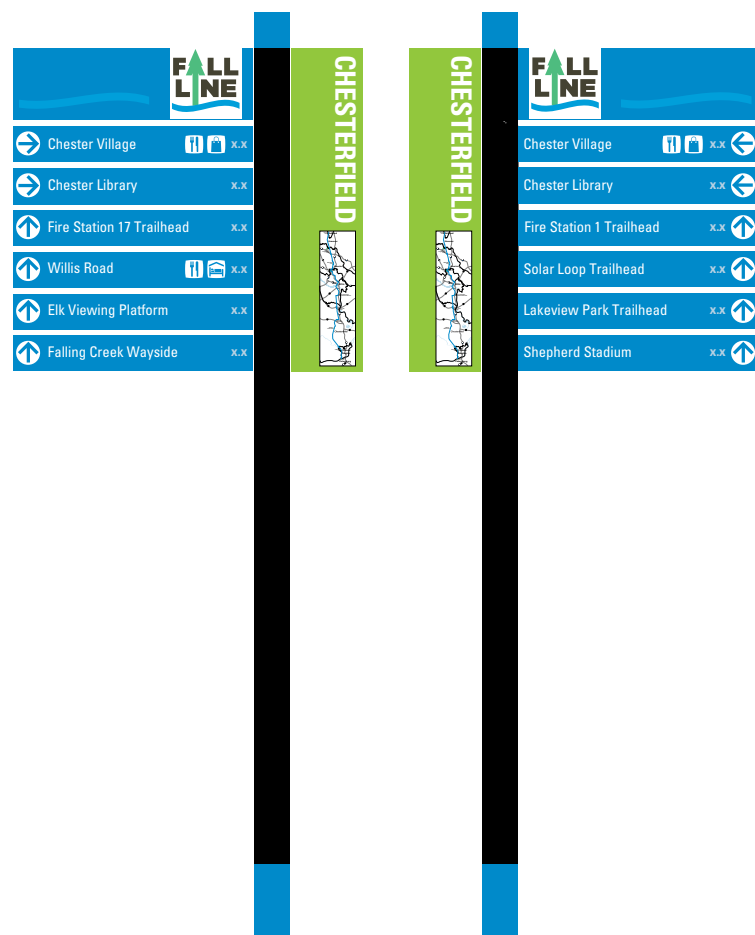

Sign Type P2.64A Pedestrian Directional  
Sign Type P2.64B Pedestrian Directional

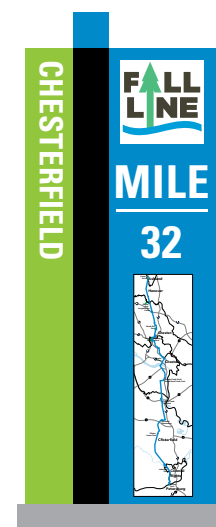

Sign Type M.32 Mile Marker



Sign Type P2.65A Pedestrian Directional

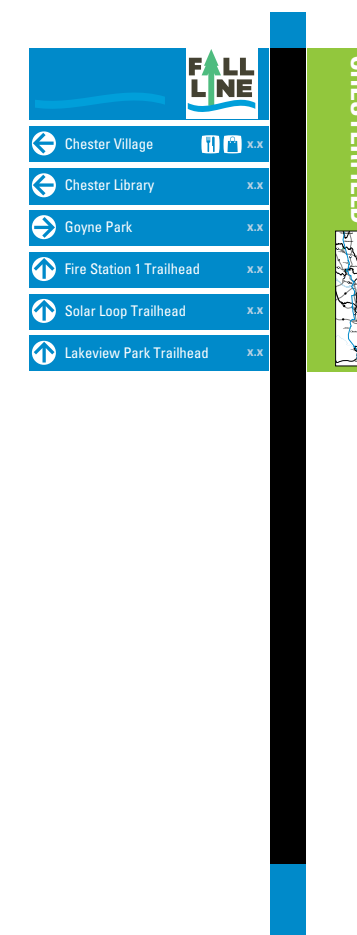

Sign Type P2.65B Pedestrian Directional

THIS DRAWING REPRESENTS DESIGN INTENT ONLY.

Date 4.29.24	Revisions 6.10.24 6.26.24	Scale 3/4" = 1'
-----------------	---------------------------------	--------------------

Client/Project  
CVTA, Virginia  
Wayfinding for Fall Line Trail

© 2024 AB Design, Inc.



**PROGRAMMING**  
Sign Location Plan  
Chesterfield

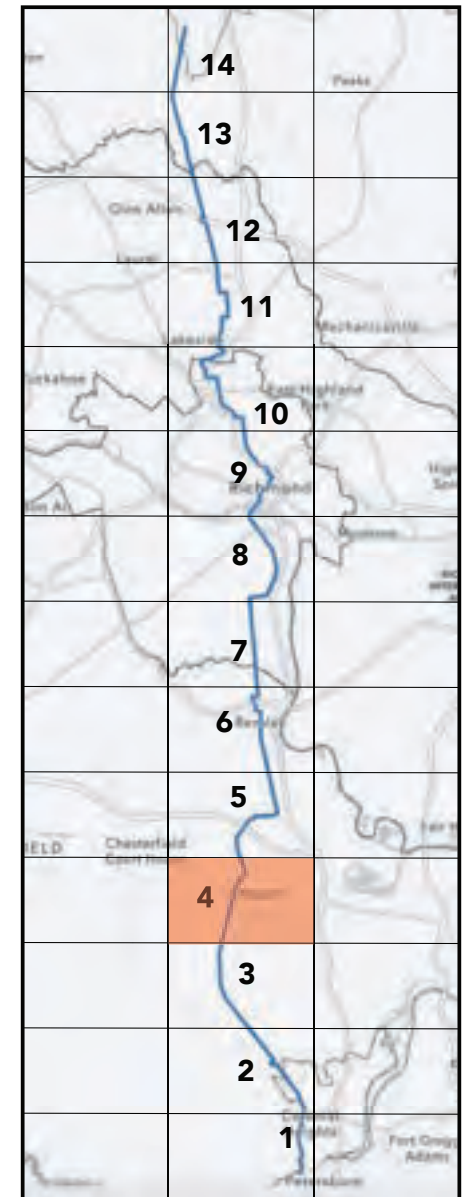

THIS DRAWING REPRESENTS DESIGN INTENT ONLY.

Date 4.29.24	Revisions 6.10.24 6.26.24	Scale NTS
-----------------	---------------------------------	--------------

Client/Project  
CVTA, Virginia  
Wayfinding for Fall Line Trail

© 2024 AB Design, Inc.

**CH.18**

**SIGNTYPES KEY**

ID	Landmark Id.
M	Mile marker
P	Pedestrian Directional
PL	Plate
T	Trailhead Sign
U	Urban/ParkingMarker
V	Vehicular Directional
W	Directional
	Trail Access Point



**PROGRAMMING**  
Sign Location Plan  
Chesterfield

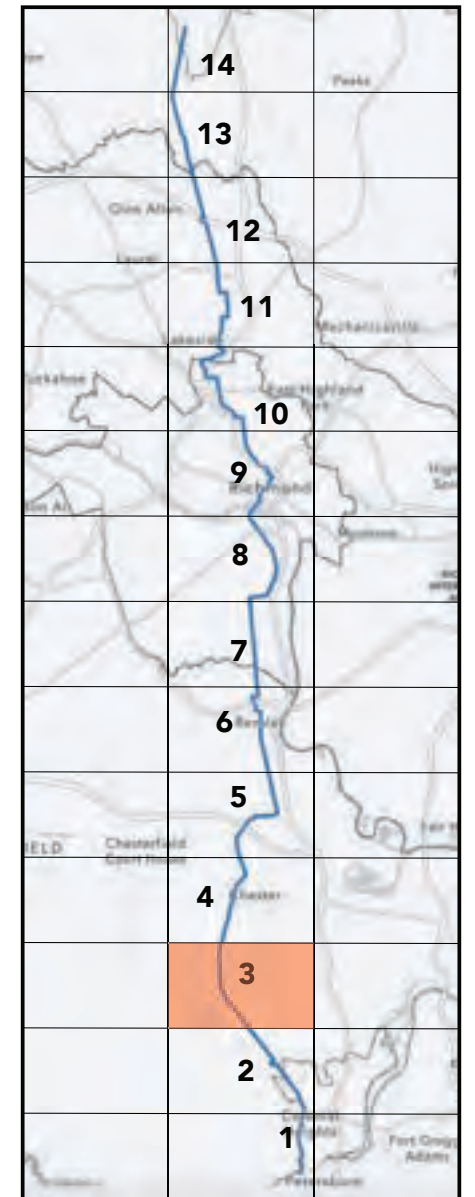

THIS DRAWING REPRESENTS DESIGN INTENT ONLY.

Date 4.29.24	Revisions 6.10.24 6.26.24	Scale NTS
-----------------	---------------------------------	--------------

Client/Project  
CVTA, Virginia  
Wayfinding for Fall Line Trail

**SIGNTYPES KEY**

<span style="background-color: #f08080; border: 1px solid black; padding: 2px;">ID</span>	Landmark Id.
<span style="background-color: #0070c0; border: 1px solid black; padding: 2px;">M</span>	Mile marker
<span style="background-color: #e91e63; border: 1px solid black; padding: 2px;">P</span>	Pedestrian Directional
<span style="background-color: #ff9933; border: 1px solid black; padding: 2px;">PL</span>	Plate
<span style="background-color: #00b09b; border: 1px solid black; padding: 2px;">T</span>	Trailhead Sign
<span style="background-color: #90ee90; border: 1px solid black; padding: 2px;">U</span>	Urban/ParkingMarker
<span style="background-color: #6a3d9a; border: 1px solid black; padding: 2px;">V</span>	Vehicular Directional
<span style="background-color: #9370db; border: 1px solid black; padding: 2px;">W</span>	Directional
<span style="background-color: #32cd32; border: 1px solid black; border-radius: 50%; padding: 2px; display: inline-block; width: 10px; height: 10px;"></span>	Trail Access Point

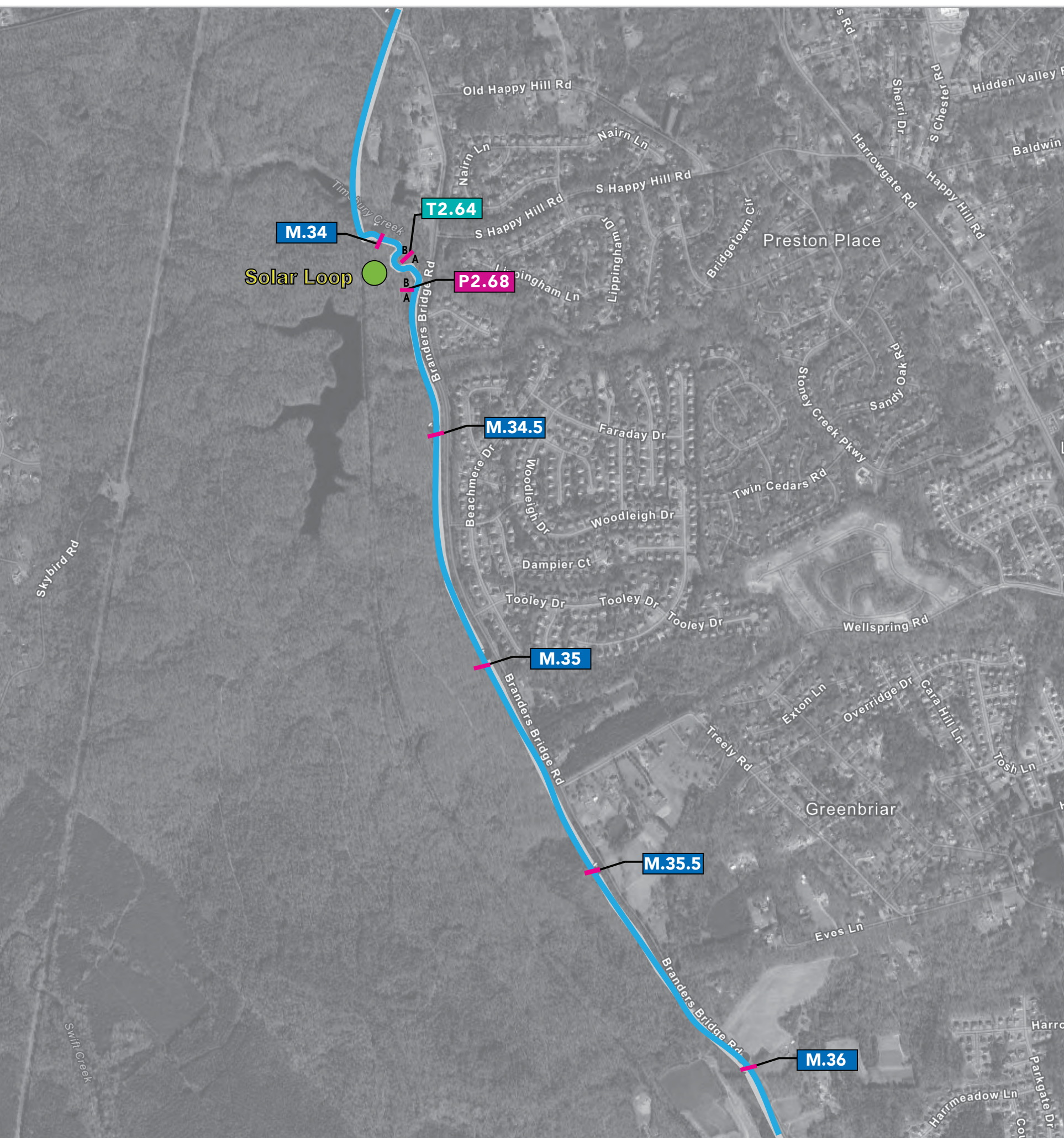

PROGRAMMING

Sign Types  
Chesterfield



Sign Type T2.63A  
Pedestrian TrailRad/  
Regulatory Sign

Sign Type T2.63B  
Pedestrian TrailRad/  
Regulatory Sign

Sign Type P2.66A  
Pedestrian Directional

Sign Type P2.66B  
Pedestrian Directional

Sign Type W.74A  
Directional Sign

W.74B

Sign Type M.32.5  
Mile Marker

THIS DRAWING REPRESENTS DESIGN INTENT ONLY.

Date	Revisions	Scale
4.29.24	6.10.24 6.26.24	3/4"=1'

Client/Project  
CVTA, Virginia  
Wayfinding for Fall Line Trail

© 2024 AB Design, Inc.



PROGRAMMING

Sign Types  
Chesterfield



Sign Type M.33  
Mile Marker

Sign Type M.33.5  
Mile Marker

Sign Type P2.67A  
Pedestrian Directional

Sign Type P2.67B  
Pedestrian Directional

Sign Type M.34  
Mile Marker

Sign Type T2.64A  
Pedestrian TrailRad/  
Regulatory Sign

Sign Type T2.64B  
Pedestrian TrailRad/  
Regulatory Sign

THIS DRAWING REPRESENTS DESIGN INTENT ONLY.

Date	Revisions	Scale
4.29.24	5.16.24 6.28.24 6.10.24	3/4" = 1'

Client/Project  
CVTA, Virginia  
Wayfinding for Fall Line Trail

© 2024 AB Design, Inc.

PROGRAMMING

Sign Types  
Chesterfield

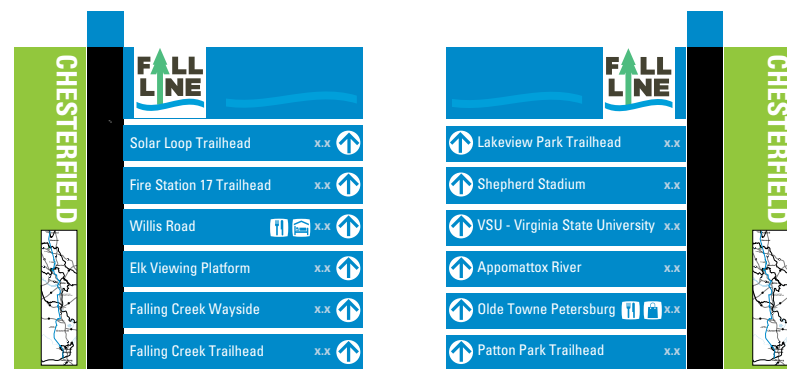

Sign Type P2.68A  
Pedestrian Directional

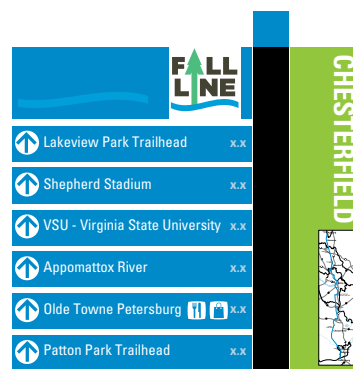

Sign Type P2.68B  
Pedestrian Directional



Sign Type M.34.5  
Mile Marker

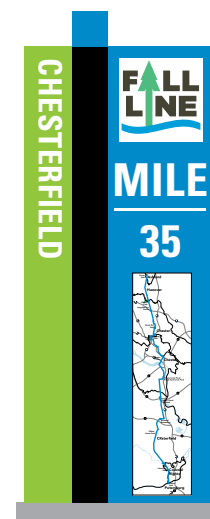

Sign Type M.35  
Mile Marker

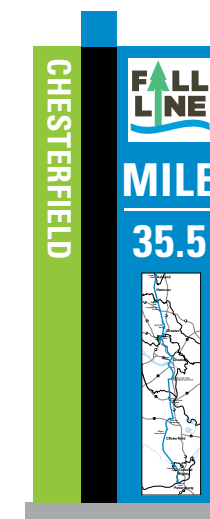

Sign Type M.35.5  
Mile Marker



Sign Type M.36  
Mile Marker

THIS DRAWING REPRESENTS DESIGN INTENT ONLY.

Date 4.29.24	Revisions 6.10.24 6.26.24	Scale 3/4" = 1'
-----------------	---------------------------------	--------------------

Client/Project  
CVTA, Virginia  
Wayfinding for Fall Line Trail

© 2024 AB Design, Inc.



**PROGRAMMING**  
 Sign Location Plan  
 Chesterfield

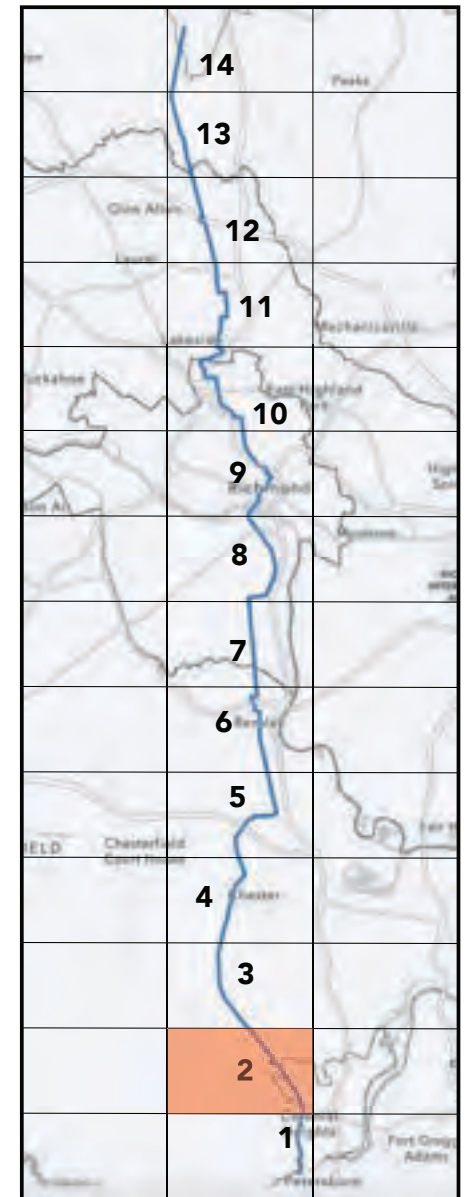

THIS DRAWING REPRESENTS DESIGN INTENT ONLY.

Date 4.29.24	Revisions 6.10.24 6.26.24	Scale NTS
-----------------	---------------------------------	--------------

Client/Project  
 CVTA, Virginia  
 Wayfinding for Fall Line Trail

© 2024 AB Design, Inc.

**CH.23**



**SIGNTYPES KEY**

- ID Landmark Id.
- M Mile marker
- P Pedestrian Directional
- PL Plate
- T Trailhead Sign
- U Urban/ParkingMarker
- V Vehicular Directional
- W Directional
- Trail Access Point

PROGRAMMING

Sign Types  
Chesterfield



Sign Type P2.69A  
Pedestrian Directional

Sign Type P2.69B  
Pedestrian Directional

Sign Type W.75A  
Directional Sign

W.75B

Sign Type M.36.5  
Mile Marker

Sign Type M.37  
Mile Marker

Sign Type M.37.5  
Mile Marker

THIS DRAWING REPRESENTS DESIGN INTENT ONLY.

Date 4.29.24	Revisions 6.10.24 6.26.24	Scale 3/4" = 1'
-----------------	---------------------------------	--------------------

Client/Project  
CVTA, Virginia  
Wayfinding for Fall Line Trail

© 2024 AB Design, Inc.

PROGRAMMING

Sign Types  
Chesterfield

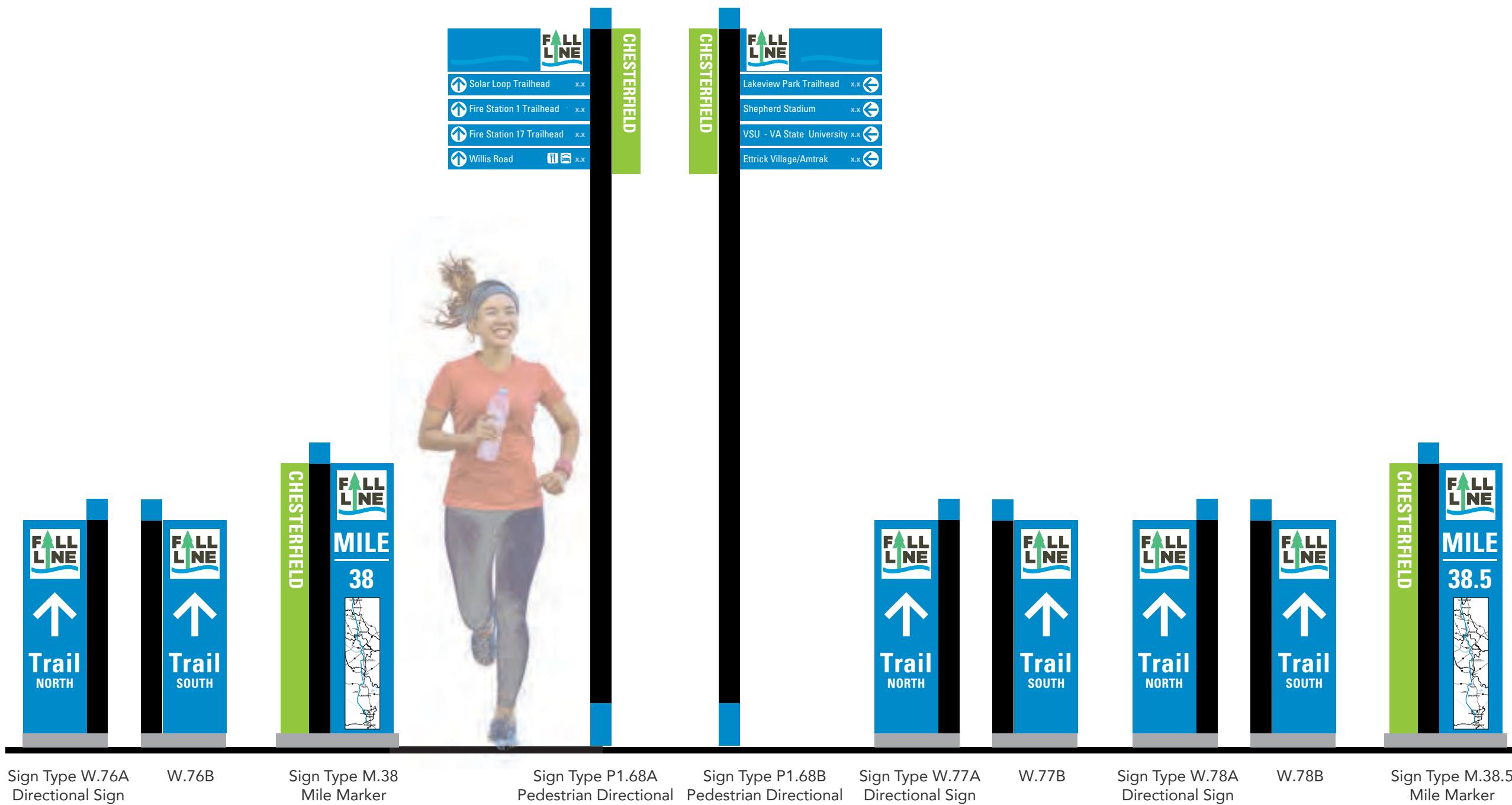

THIS DRAWING REPRESENTS DESIGN INTENT ONLY.

Date	Revisions	Scale
4.29.24	6.10.24 8.28.24	3/4" = 1'

Client/Project  
CVTA, Virginia  
Wayfinding for Fall Line Trail

© 2024 AB Design, Inc.

June 2024



# CVTA Wayfinding for Fall Line Trail

Programming  
Colonial Heights/  
Petersburg



1005 Stonemill Road  
Richmond, Virginia 23233  
Phone: 804-346-4771  
Fax: 804-325-1751  
[www.abdesignonline.com](http://www.abdesignonline.com)



**PROGRAMMING**  
Sign Location Plan  
Colonial Heights

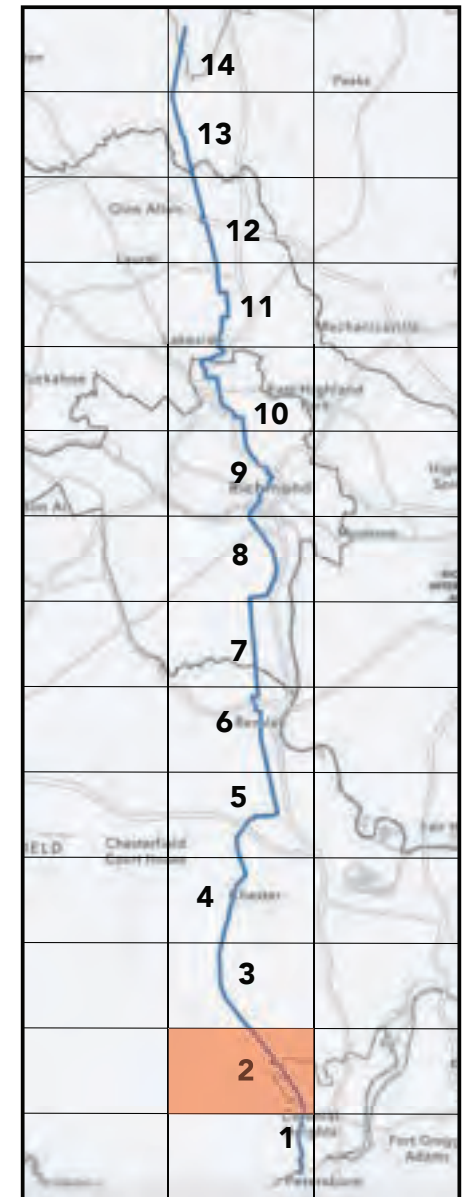

THIS DRAWING REPRESENTS DESIGN INTENT ONLY.

Date 4.30.24	Revisions 6.10.24 6.26.24	Scale NTS
-----------------	---------------------------------	--------------

Client/Project  
CVTA, Virginia  
Wayfinding for Fall Line Trail

© 2024 AB Design, Inc.

**C0.1**



**SIGNTYPES KEY**

- ID Landmark Id.
- M Mile marker
- P Pedestrian Directional
- PL Plate
- T Trailhead Sign
- U Urban/ParkingMarker
- V Vehicular Directional
- W Directional
- Trail Access Point



**PROGRAMMING**  
Sign Location Plan  
Colonial Heights

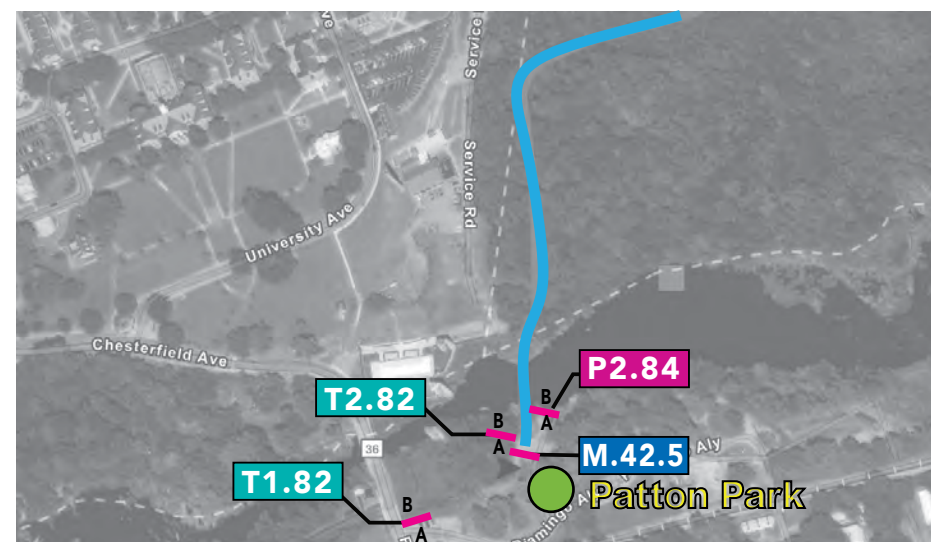

Petersburg

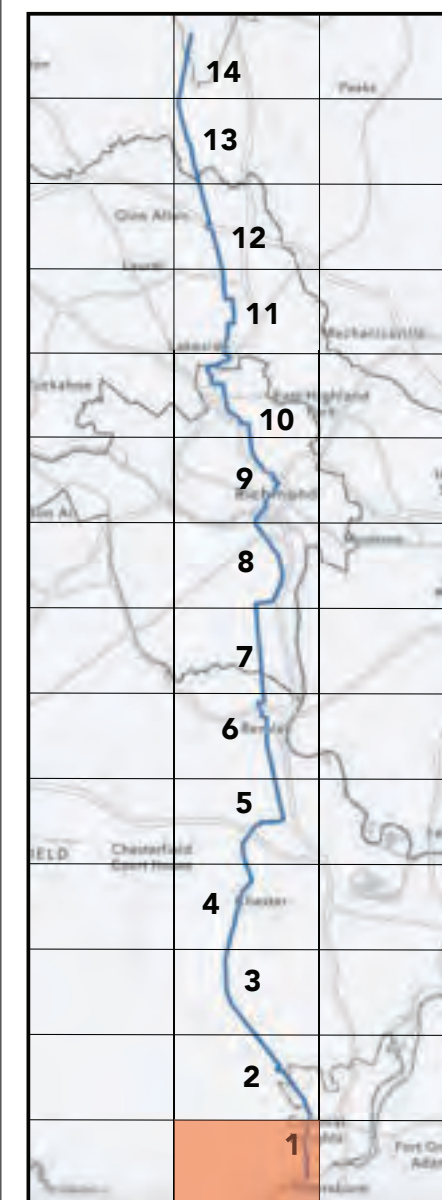

THIS DRAWING REPRESENTS DESIGN INTENT ONLY.

Date 4.30.24	Revisions 6.10.24 6.26.24	Scale NTS
-----------------	---------------------------------	--------------

Client/Project  
CVTA, Virginia  
Wayfinding for Fall Line Trail

© 2024 AB Design, Inc.

**CO.2**

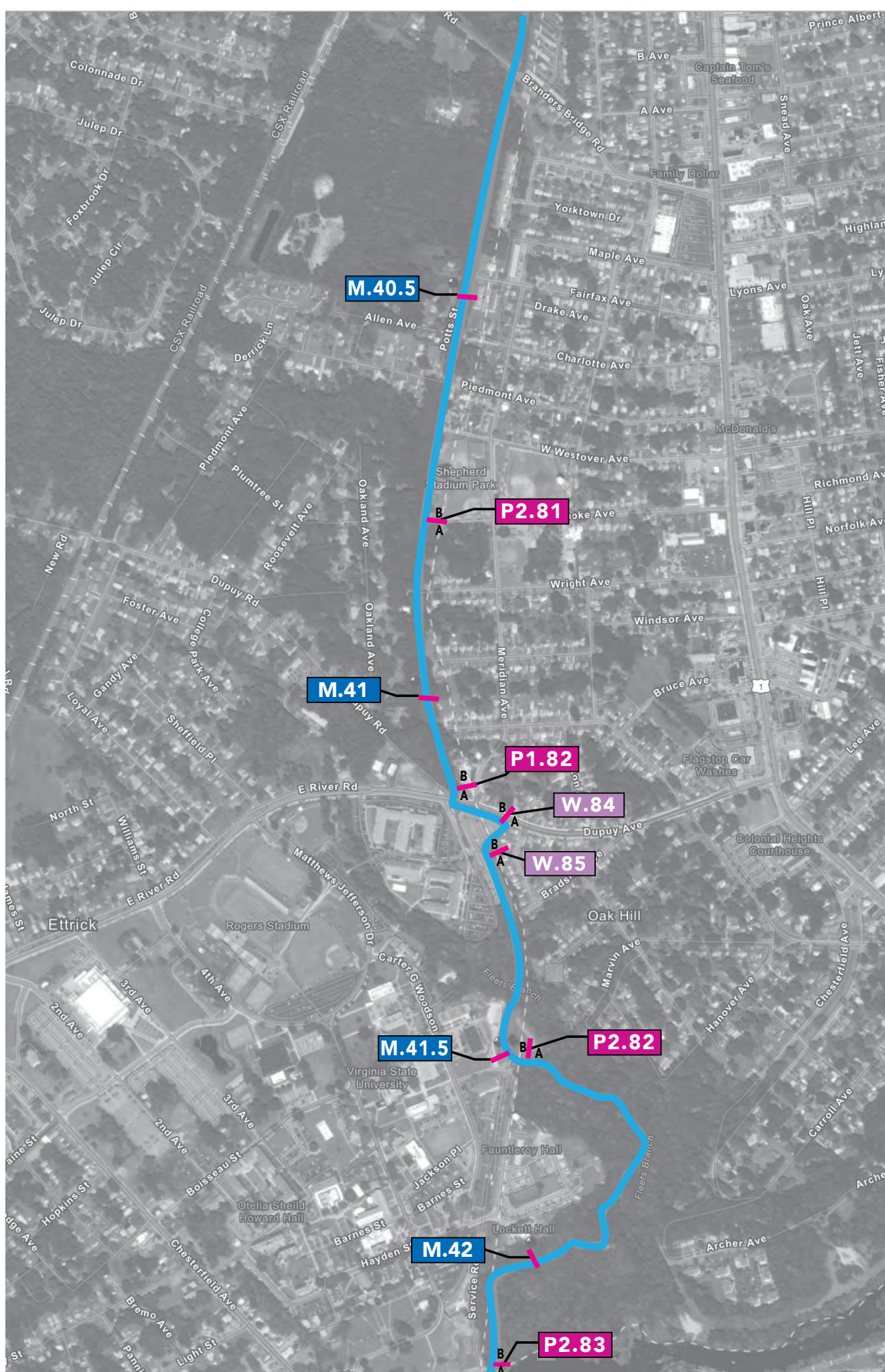

**SIGNTYPES KEY**

- ID Landmark Id.
- M Mile marker
- P Pedestrian Directional
- PL Plate
- T Trailhead Sign
- U Urban/ParkingMarker
- V Vehicular Directional
- W Directional
- Trail Access Point



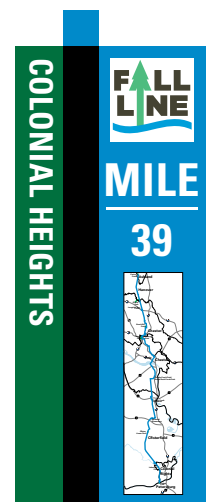

Sign Type M.39  
Mile Marker



Sign Type T2.81A  
Pedestrian TrailRad/  
Regulatory Sign



Sign Type T2.81B  
Pedestrian TrailRad/  
Regulatory Sign



Sign Type T1.81A  
Vehicular  
TrailRad Sign



Sign Type T1.81B  
Vehicular  
TrailRad Sign

THIS DRAWING REPRESENTS DESIGN INTENT ONLY.

Date	Revisions	Scale
4.30.24	6.10.24 6.26.24	3/4"=1'

Client/Project  
CVTA, Virginia  
Wayfinding for Fall Line Trail

© 2024 AB Design, Inc.

PROGRAMMING  
Sign Types  
Colonial Heights



Sign Type W.81A  
Directional Sign



W.81B

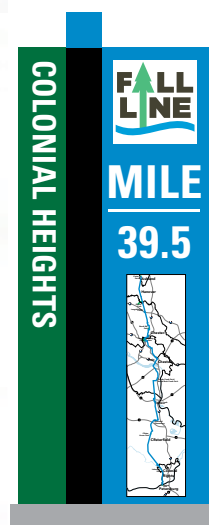

Sign Type M.39.5  
Mile Marker



Sign Type W.82A  
Directional Sign



W.82B



Sign Type W.83A  
Directional Sign



W.83B

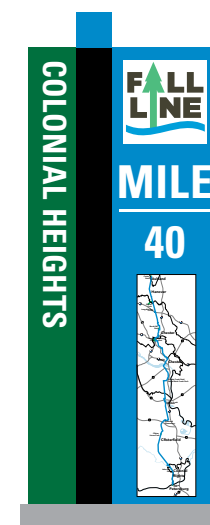

Sign Type M.40  
Mile Marker

THIS DRAWING REPRESENTS DESIGN INTENT ONLY.

Date	Revisions	Scale
4.30.24	6.10.24 6.26.24	3/4" = 1'

Client/Project  
CVTA, Virginia  
Wayfinding for Fall Line Trail

© 2024 AB Design, Inc.

Some of these signs are on the border between Colonial Heights and Chesterfield or are technically in Chesterfield. The Colonial Heights side banner is used for these signs to provide continuity and avoid confusion for the trail user.

**PROGRAMMING**  
Sign Types  
Colonial Heights

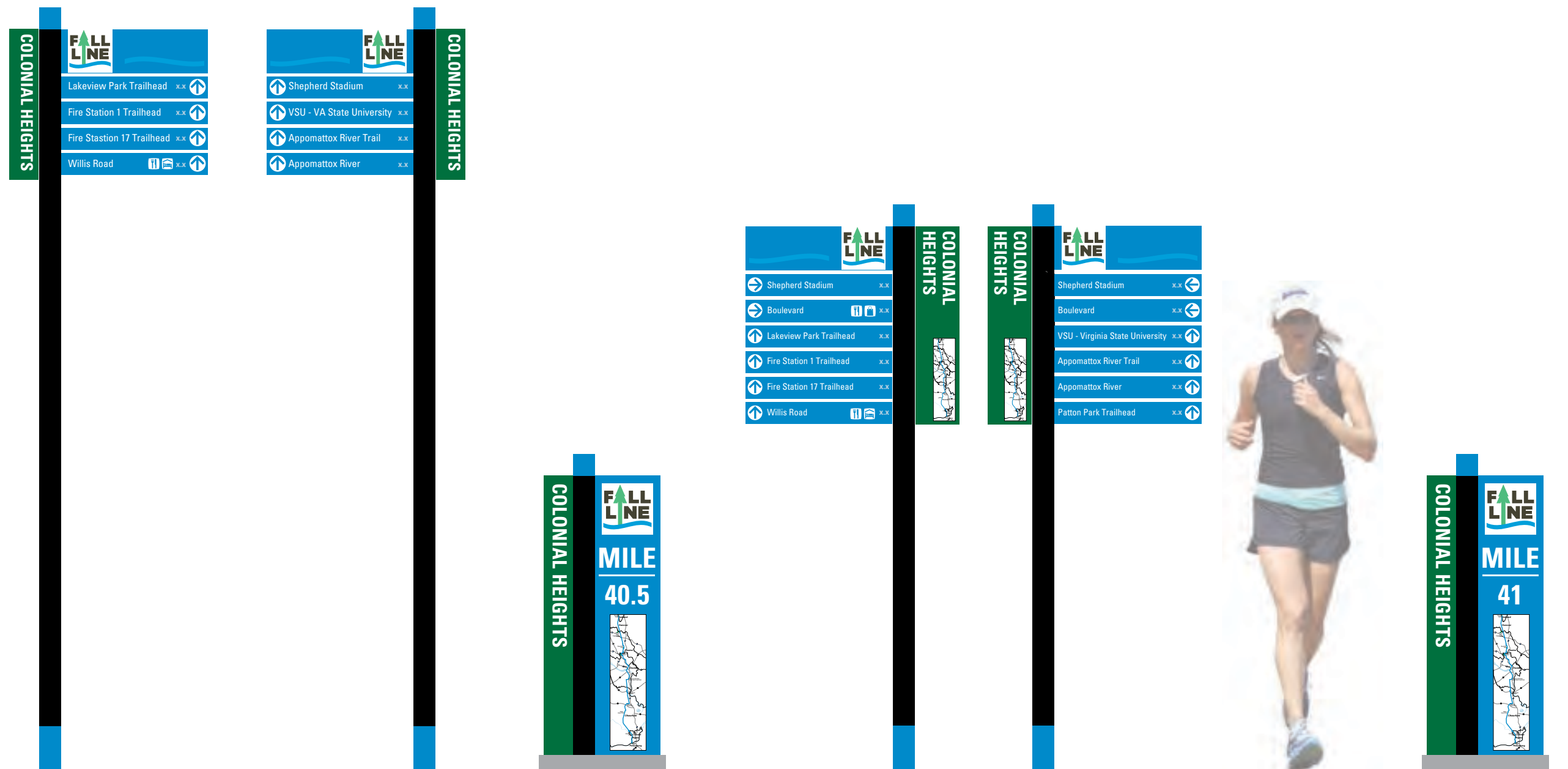

Sign Type P1.81A  
Pedestrian Directional

Sign Type P1.81B  
Pedestrian Directional

Sign Type M.40.5  
Mile Marker

Sign Type P2.81A  
Pedestrian Directional

Sign Type P2.81B  
Pedestrian Directional

Sign Type M.41  
Mile Marker

THIS DRAWING REPRESENTS DESIGN INTENT ONLY.

Date 4.30.24	Revisions 6.10.24 6.26.24	Scale 3/4" = 1'
-----------------	---------------------------------	--------------------

Client/Project  
CVTA, Virginia  
Wayfinding for Fall Line Trail

© 2024 AB Design, Inc.

**CO.5**

PROGRAMMING

Sign Types  
Colonial Heights

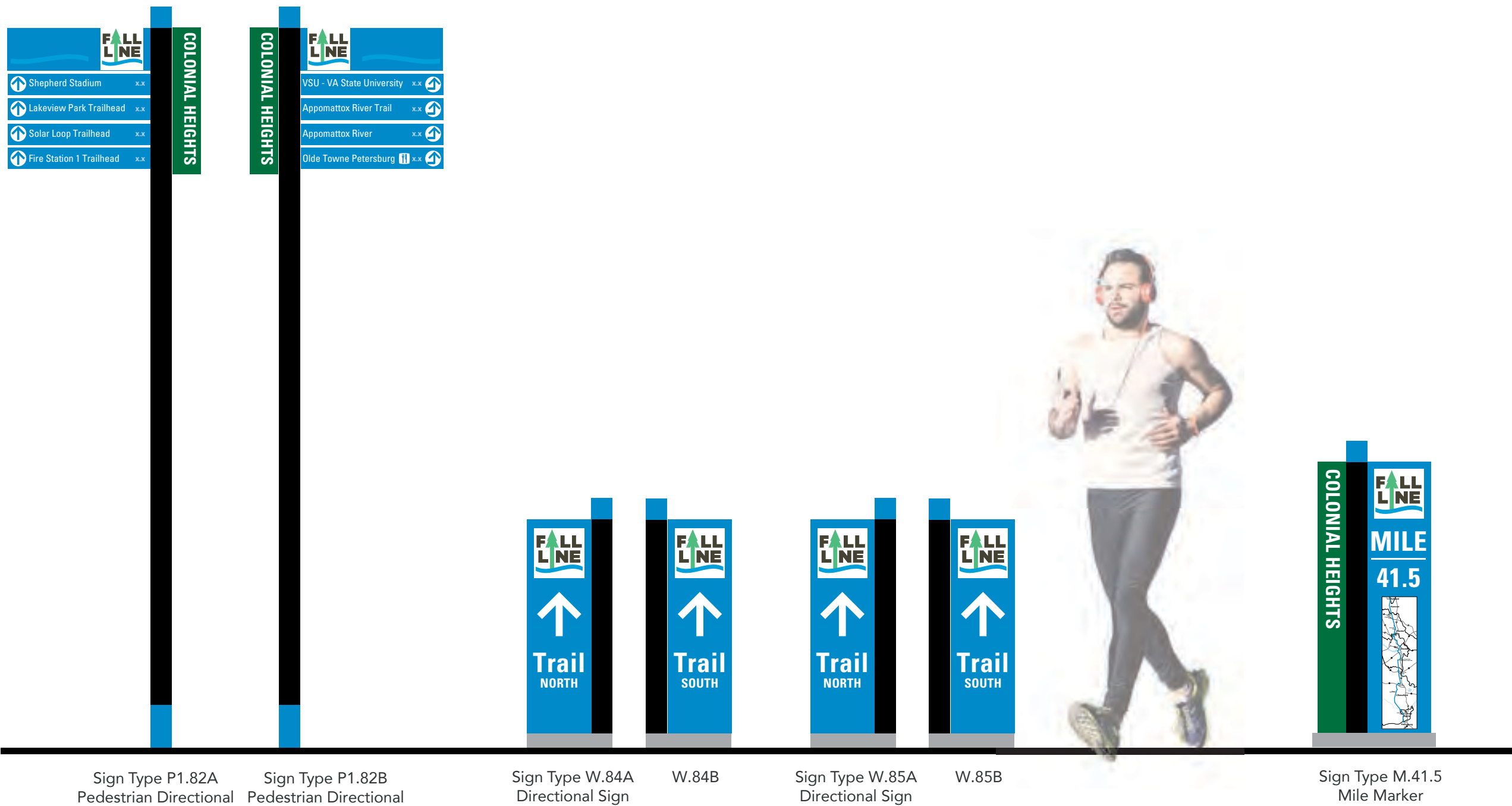

THIS DRAWING REPRESENTS DESIGN INTENT ONLY.

Date 4.30.24	Revisions 6.10.24 6.26.24	Scale 3/4" = 1'
-----------------	---------------------------------	--------------------

Client/Project  
CVTA, Virginia  
Wayfinding for Fall Line Trail

© 2024 AB Design, Inc.

**CO.6**

PROGRAMMING  
Sign Types  
Colonial Heights

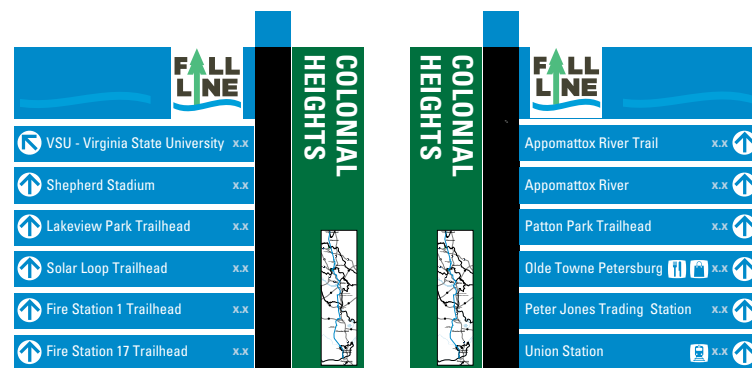

Sign Type P2.82A Pedestrian Directional Sign Type P2.82B Pedestrian Directional

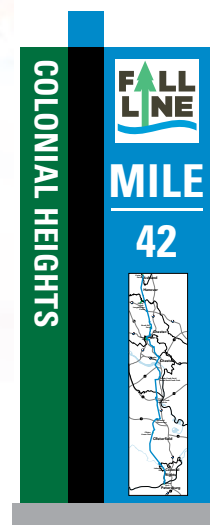

Sign Type M.42 Mile Marker

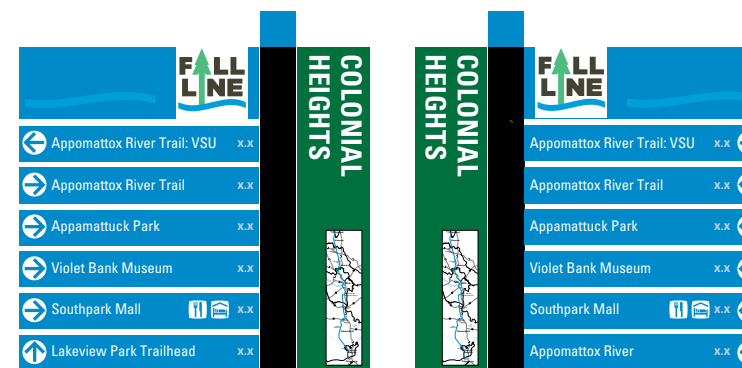

Sign Type P2.83A Pedestrian Directional Sign Type P2.83B Pedestrian Directional



THIS DRAWING REPRESENTS DESIGN INTENT ONLY.

Date 4.30.24	Revisions 6.10.24 6.26.24	Scale 3/4" = 1'
-----------------	---------------------------------	--------------------

Client/Project  
CVTA, Virginia  
Wayfinding for Fall Line Trail

© 2024 AB Design, Inc.

**CO.7**

PROGRAMMING  
Sign Types  
Colonial Heights



Sign Type P2.84A Pedestrian Directional Sign Type P2.84B Pedestrian Directional

Sign Type T2.82A Pedestrian TrailRad/Regulatory Sign

Sign Type T2.82B Pedestrian TrailRad/Regulatory Sign

Sign Type M.42.5 Mile Marker

THIS DRAWING REPRESENTS DESIGN INTENT ONLY.

Date 5.2.24	Revisions 6.10.24 6.26.24	Scale 3/4" = 1'
----------------	---------------------------------	--------------------

Client/Project  
CVTA, Virginia  
Wayfinding for Fall Line Trail

© 2024 AB Design, Inc.



Sign Type T1.27A  
Vehicular  
Trailhead Sign

Sign Type T1.27A  
Vehicular  
Trailhead Sign

THIS DRAWING REPRESENTS DESIGN INTENT ONLY.

Date 5.2.24	Revisions 6.10.24 6.26.24	Scale 3/4" = 1'
----------------	---------------------------------	--------------------

Client/Project  
CVTA, Virginia  
Wayfinding for Fall Line Trail

June 2024



# CVTA Wayfinding for Fall Line Trail



10005 Stonemill Road  
Richmond, Virginia 23233  
Phone: 804-346-4771  
Fax: 804-325-1751  
[www.abdesignonline.com](http://www.abdesignonline.com)





---

# Graphic Standards

---

# TABLE OF CONTENTS

---

## Graphic Standards

- Typefaces..... 3
- Logos, Icons, Arrows .....4
- Color Palette.....5
- Sign Family .....6-9

## Sign-type Drawings & Details

- T1 - Vehicular Trailhead/Parking Sign..... 9
- V1 - Vehicular Directional ..... 10
- U/P - Urban Marker/ Parking Marker..... 11
- ID - Landmark Identification..... 12
- B - Banner.....13
- T2 - Pedestrian Trailhead/Regulatory Sign.....14
- P1 - Pedestrian Directional On Street.....15
- P2 - Pedestrian Directiona Off Street..... 16
- M - Mile Marker..... 17
- W - Directional Sign..... 18
- VI - Vinyl Decal / Metallic Plate.....19
- G1 - Ground Decal.....20
- G2 - Ground Stencil.....21
- Detail Cantilevered Signs.....22
- Detail for Cantilevered Signs With Inserts 1.....23
- Detail for Cantilevered Signs With Inserts 2.....24
- Detail for Breakaway.....25
- Detail for Pedestrian Sign’s Base.....26



## GRAPHIC STANDARDS

### Typefaces

#### Typefaces

Gotham Condensed Medium  
Gotham Condensed Bold

#### Notes

Substitute typefaces are not acceptable.

Univers Bold Condensed 67 is the primary weight. For some signs, Univers Condensed 57 is used to emphasize lines of type.

No other weights or versions of the fonts are acceptable, nor is it to be electronically distorted vertically or horizontally. Some kerning and tracking may need to be adjusted in certain instances to achieve optical evenness; tracking should generally be set at 50 (twenty) for vehicular signs unless noted otherwise. It may be adjusted to 0 when necessary to fit lines of type. Any further adjustment should be brought to the attention of the designer to determine if abbreviations or multiple lines are appropriate.

THIS DRAWING REPRESENTS DESIGN INTENT ONLY.

Date	Revisions	Scale
7.8.23		NTS

Client/Project  
CVTA, Virginia  
Wayfinding for Fall Line Trail

© 2024 AB Design, Inc.

## FONTS:

ABCDEFGHIJKLMNOPQRSTUVWXYZ

1234567890 abcdefghijklmnopqrstuvwxyz

Univers Condensed 57

**ABCDEFGHIJKLMNOPQRSTUVWXYZ**

**1234567890 abcdefghijklmnopqrstuvwxyz**

Univers Bold Condensed 67

LOGOS, ICONS & ARROWS

LOGOS



ACTIVITY & DESTINATION ICONS

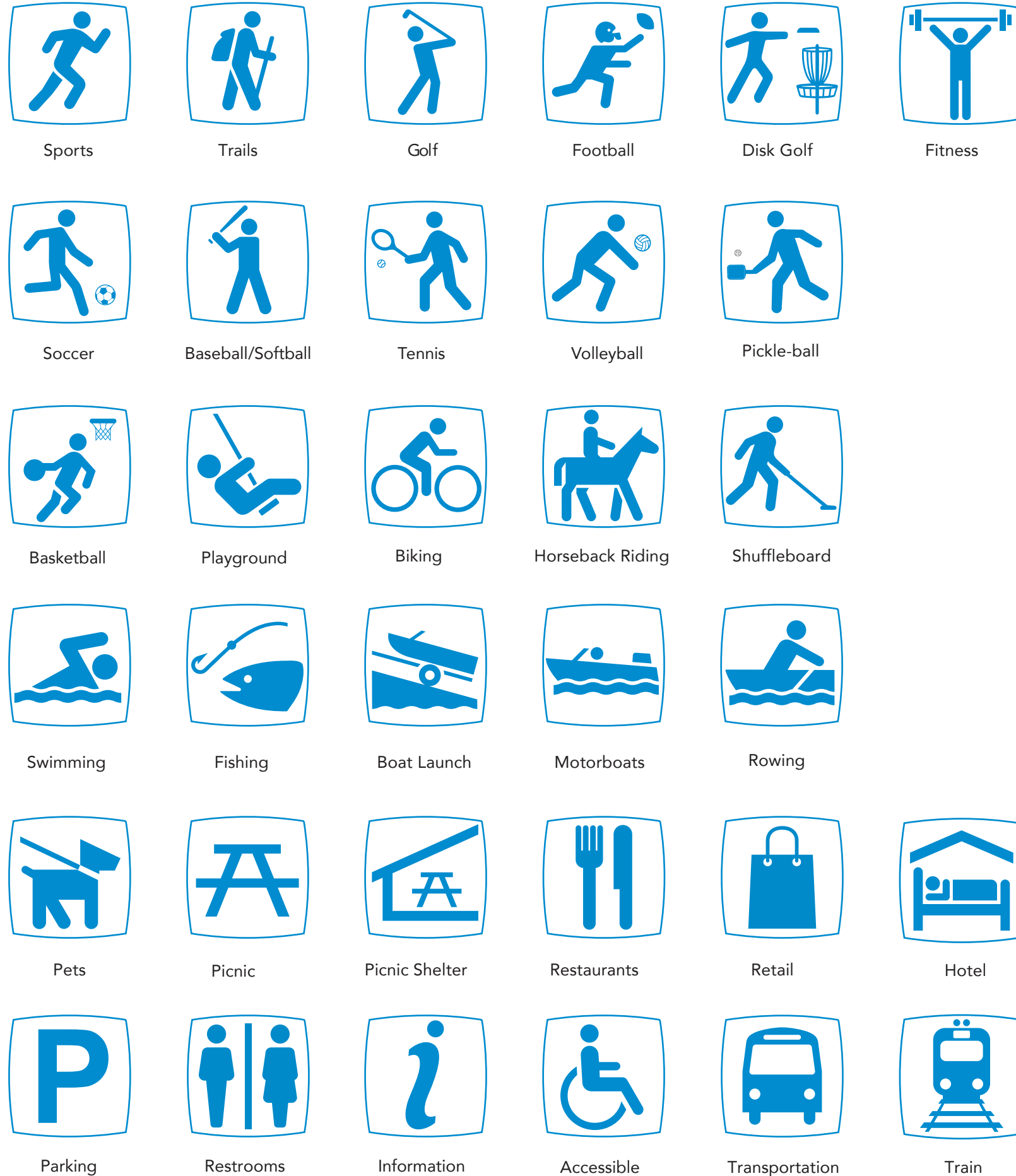

ARROWS

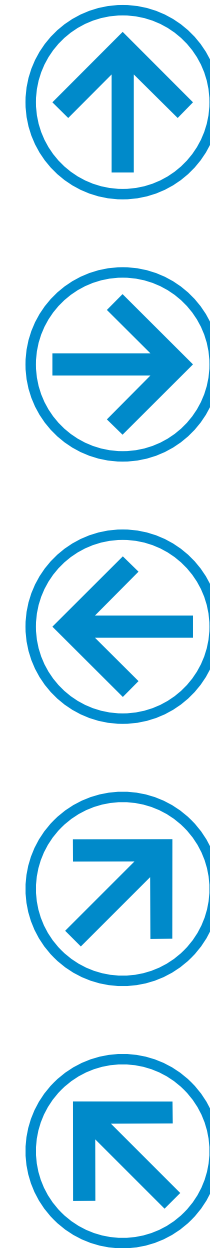

GRAPHIC STANDARDS

Logos, Icons & Arrows

Logos, icons and arrows will be provided as digital files by AB Design.

Production artwork files to be available as vectorized files which are scalable vector formats. They can be opened in most industry standard design and publishing software.

Reconstructed art or digitized versions from printed copies shall not be used. Only original electronic files generated by AB Design may be used for application onto signage. Substitute arrows or symbols are not acceptable.

THIS DRAWING REPRESENTS DESIGN INTENT ONLY.

Date	Revisions	Scale
7.8.23	5.29.24	NTS

Client/Project  
CVTA, Virginia  
Wayfinding for Fall Line Trail

# COLOR PALETTE:



**C1**

Dark Blue  
Pantone  
P109-7C

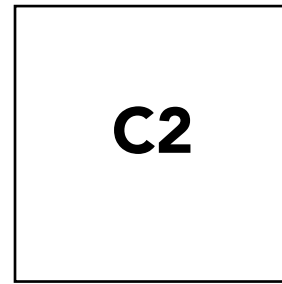

**C2**

White



**C3**

Black

# COLOR: SECTIONS



Ashland  
Pantone  
P124-7C



Hanover  
C-100  
M-99  
Y27  
K31



Henrico  
Pantone  
P104-16C



Richmond  
Pantone  
P53-16C



Chesterfield  
Pantone  
P157-8C



Colonial Heights  
Pantone  
P140-16C



Petersburg  
Pantone  
347U

## GRAPHIC STANDARDS Color Palette

It is the Fabricator's responsibility to match all colors, finishes and materials specified in this document.

The visual accuracy of the colors and finishes represented in this document may not be consistent with manufacturer's swatches and samples due to limitations of color printing technology.

The Fabricator is required to match against actual color swatches and provide material samples for approval prior to production.

If a substitute or deviation is recommended by the Fabricator, the recommendation shall be proposed in writing with a demonstration of equal or better value for consideration.

THIS DRAWING REPRESENTS DESIGN INTENT ONLY.

Date	Revisions	Scale
8.31.23	10.23.23	NTS

Client/Project  
CVTA, Virginia  
Wayfinding for Fall Line Trail

© 2024 AB Design, Inc.



# GRAPHIC STANDARDS Sign Family

These drawings represent design intent only, not for construction. The fabricator is responsible for all final engineering and should submit shop drawings for approval, before proceeding with fabrication.

Any variations to design, materials, or fabrication methods must be approved by the Client and the Designer.

The final product quality of fit and finish must meet or exceed the requirements of these design intent documents

Colors shown are for reference only and color samples should be presented for approval prior to fabrication.

The fabricator should verify actual site conditions and perform detailed site surveys before the fabrication and installation.

These drawings show messages for general reference only. Refer to message schedules for all required messages.

THIS DRAWING REPRESENTS DESIGN INTENT ONLY.

Date	Revisions	Scale
8.31.23	11.6.23 1.5.24	3.22.24 3/4" = 1'

Client/Project  
CVTA, Virginia  
Wayfinding for Fall Line Trail

© 2024 AB Design, Inc.



Sign Type T1  
Vehicular  
Trailhead Sign



Sign Type V1  
Vehicular Directional

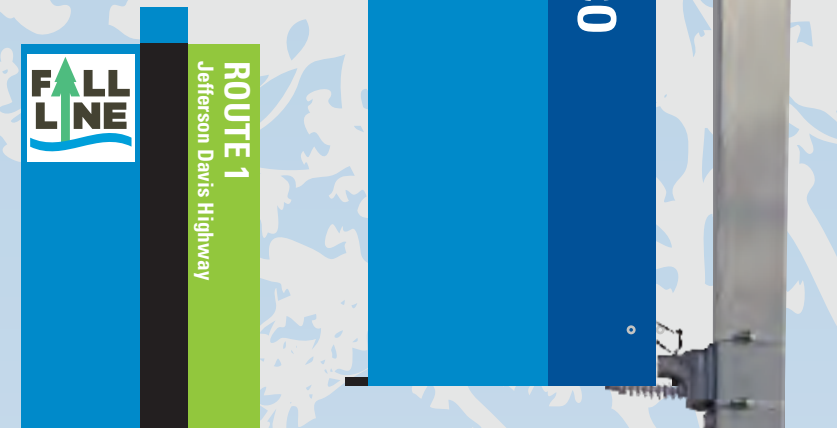

Sign Type U/P  
Urban marker/  
Parking Marker



Sign Type B  
Banner



# GRAPHIC STANDARDS

## Sign Family

These drawings represent design intent only, not for construction. The fabricator is responsible for all final engineering and should submit shop drawings for approval, before proceeding with fabrication.

Any variations to design, materials, or fabrication methods must be approved by the Client and the Designer.

The final product quality of fit and finish must meet or exceed the requirements of these design intent documents

Colors shown are for reference only and color samples should be presented for approval prior to fabrication.

The fabricator should verify actual site conditions and perform detailed site surveys before the fabrication and installation.

These drawings show messages for general reference only. Refer to message schedules for all required messages.

THIS DRAWING REPRESENTS DESIGN INTENT ONLY.

Date	Revisions		Scale
8.31.23	11.6.23	3.22.24	3/4" = 1'
	1.5.24	53.23.24	

Client/Project  
CVTA, Virginia  
Wayfinding for Fall Line Trail



Sign Type T2  
Pedestrian Trailhead/  
Regulatory Sign

Sign Type P1  
Pedestrian Directional  
On Street

Sign Type P2  
Pedestrian Directional  
Off Street

Sign Type ID  
Landmark Identification

Sign Type M  
Mile Marker

Sign Type M1  
Mile Marker  
OPTION



# GRAPHIC STANDARDS

## Sign Family

These drawings represent design intent only, not for construction. The fabricator is responsible for all final engineering and should submit shop drawings for approval, before proceeding with fabrication.

Any variations to design, materials, or fabrication methods must be approved by the Client and the Designer.

The final product quality of fit and finish must meet or exceed the requirements of these design intent documents

Colors shown are for reference only and color samples should be presented for approval prior to fabrication.

The fabricator should verify actual site conditions and perform detailed site surveys before the fabrication and installation.

These drawings show messages for general reference only. Refer to message schedules for all required messages.

THIS DRAWING REPRESENTS DESIGN INTENT ONLY.

Date	Revisions		Scale
8.31.23	11.6.23	3.22.24	3/4" = 1'
	1.5.24		

Client/Project  
CVTA, Virginia  
Wayfinding for Fall Line Trail

© 2024 AB Design, Inc.



Sign Types W  
Directional Sign

Sign Types VI  
Vinyl Decal or Wrap

Sign Type PL1  
Square Plate

Sign Type PL2  
Rectangular Plate  
Post Cap

Sign Type G1  
Vinyl Ground Decal

Sign Type G2  
Ground Stencil on Pavement





---

# Sign Drawings

---



## SIGN DETAILS - SIGN T1

### Vehicular Trailhead/ Parking Sign

Signs to have vehicular and night visibility. Trees that obscure sign face to be trimmed.

Sign to be single or double sided.

1. 1/8" Thick aluminum face and side skins chemically welded to frame conceptual design with seamless edges. All edges and corners to be ground smooth, straight, and square with no gaps or voids. NON OBTRUSIVE HARDWARE

2. Colors and graphics to be digitally printed onto 3M™ High Intensity Prismatic Reflective Sheeting 3930DS (White). Apply 3M™ Electrocut™ Film Series 1170 (Clear) to seal reflective sheeting.

3. 1/8" Thick aluminum face and side skins chemically welded to frame conceptual design with seamless edges. All edges and corners to be ground smooth, straight, and square with no gaps or voids. NON OBTRUSIVE HARDWARE

4. 5" x 5" painted steel post with breakaway attachment.

5. Post capped with welded steel plate.

6. 3000 PSI concrete footer. The size and depth of the concrete footer shall be determined by the fabricator. The footers must be certified by engineers registered in the state Virginia.

Fabricator: Check flood levels in the area and elevate the sign as needed with a longer post.

Paint Colors:

C1. Pantone P109-7C Blue

C2. White

C3. Polyurethane Clear Coat Satin

Paint-Black

Fonts:

Univers Condensed 57

Univers Bold Condensed 67

THIS DRAWING REPRESENTS DESIGN INTENT ONLY.

Date	Revisions	Scale
8.31.23		3/4" = 1'

Client/Project  
CVTA, Virginia  
Wayfinding for Fall Line Trail

© 2024 AB Design, Inc.

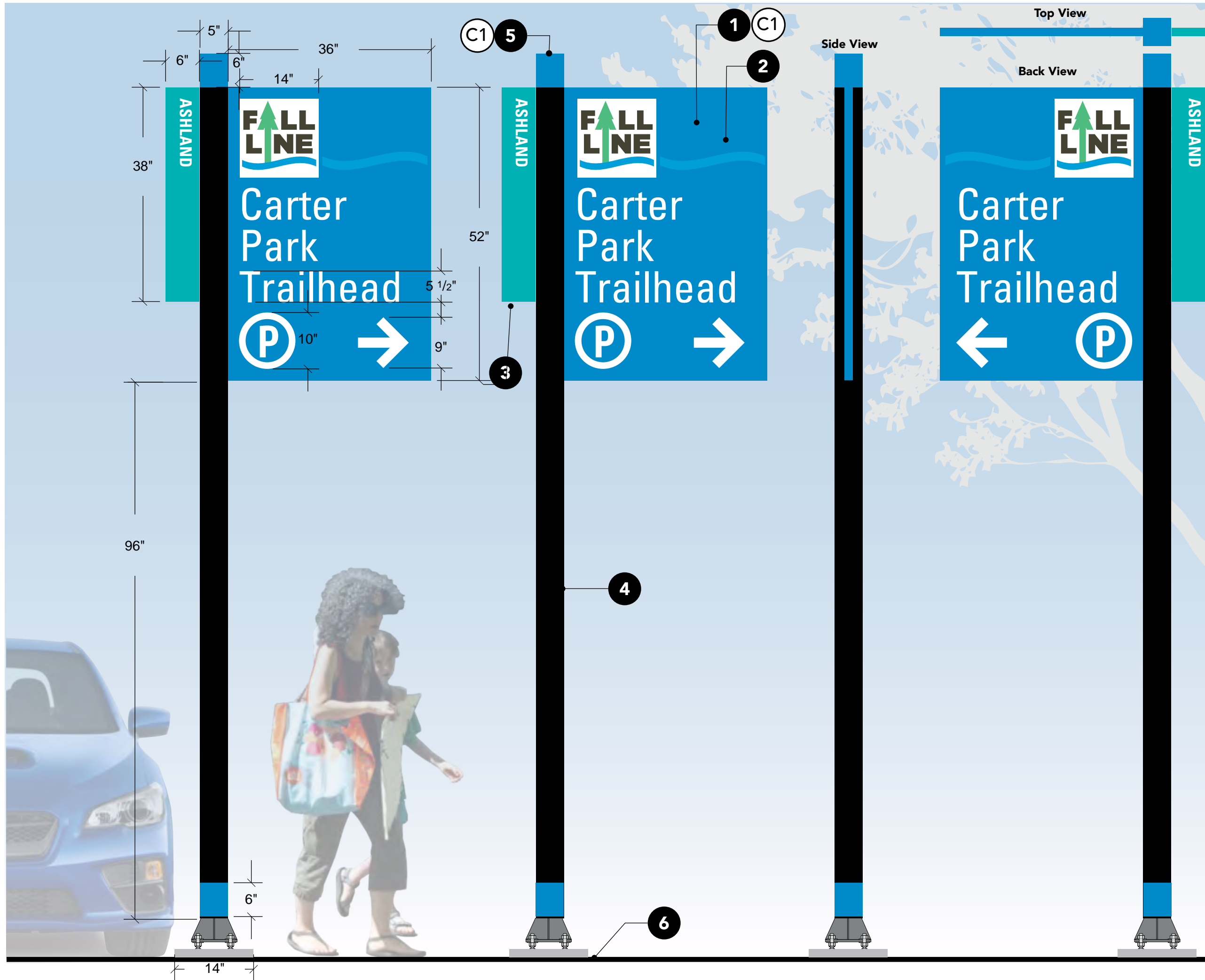



## SIGN DETAILS - SIGN V1

### Vehicular Directional

Signs to have vehicular and night visibility. Trees that obscure sign face to be trimmed.

Sign to be single or double sided.

1. 1/8" Thick aluminum face and side skins chemically welded to frame conceptual design with seamless edges. All edges and corners to be ground smooth, straight, and square with no gaps or voids. NON OBTRUSIVE HARDWARE

2. Colors and graphics to be digitally printed onto 3M™ High Intensity Prismatic Reflective Sheeting 3930DS (White). Apply 3M™ Electrocut™ Film Series 1170 (Clear) to seal reflective sheeting.

3. 1/8" Thick aluminum face and side skins chemically welded to frame conceptual design with seamless edges. All edges and corners to be ground smooth, straight, and square with no gaps or voids. NON OBTRUSIVE HARDWARE

4. 5"x 5" painted steel post with breakaway attachment.

5. Post capped with welded steel plate.

6. 3000 PSI concrete footer. The size and depth of the concrete footer shall be determined by the fabricator. The footers must be certified by engineers registered in the state Virginia.

Fabricator: Check flood levels in the area and elevate the sign as needed with a longer post.

Paint Colors:

C1. Pantone P109-7C Blue

C2. White

C3. Polyurethane Clear Coat Satin

Paint-Black

Fonts:

Univers Condensed 57

Univers Bold Condensed 67

THIS DRAWING REPRESENTS DESIGN INTENT ONLY.

Date	Revisions	Scale
8.31.23	5.23.24	3/4" = 1'

Client/Project  
CVTA, Virginia  
Wayfinding for Fall Line Trail

© 2024 AB Design, Inc.

10

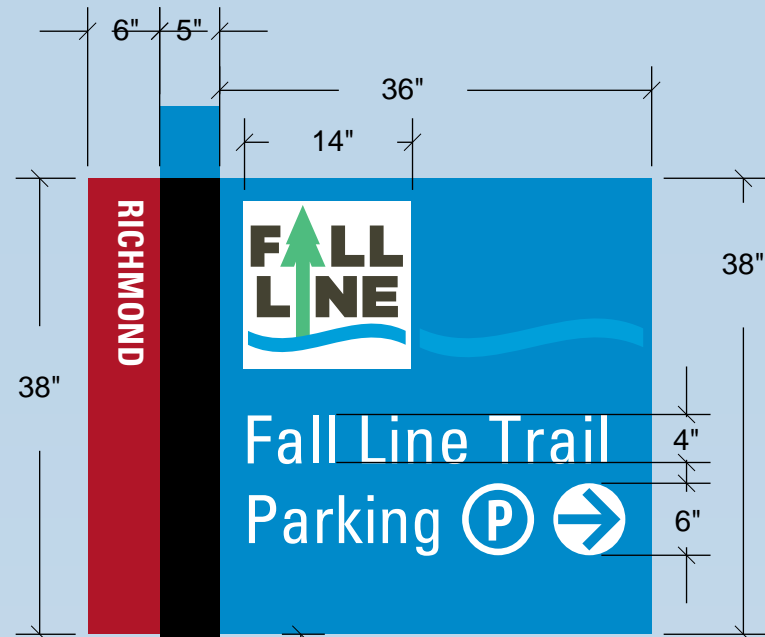

Side View

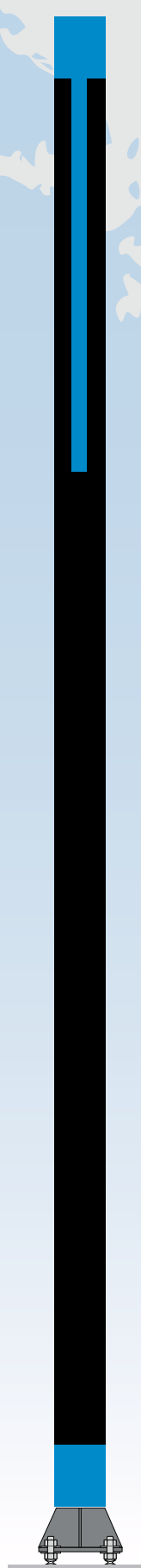

Top View

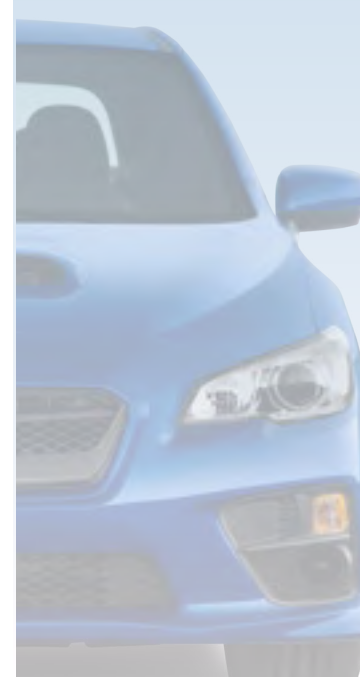
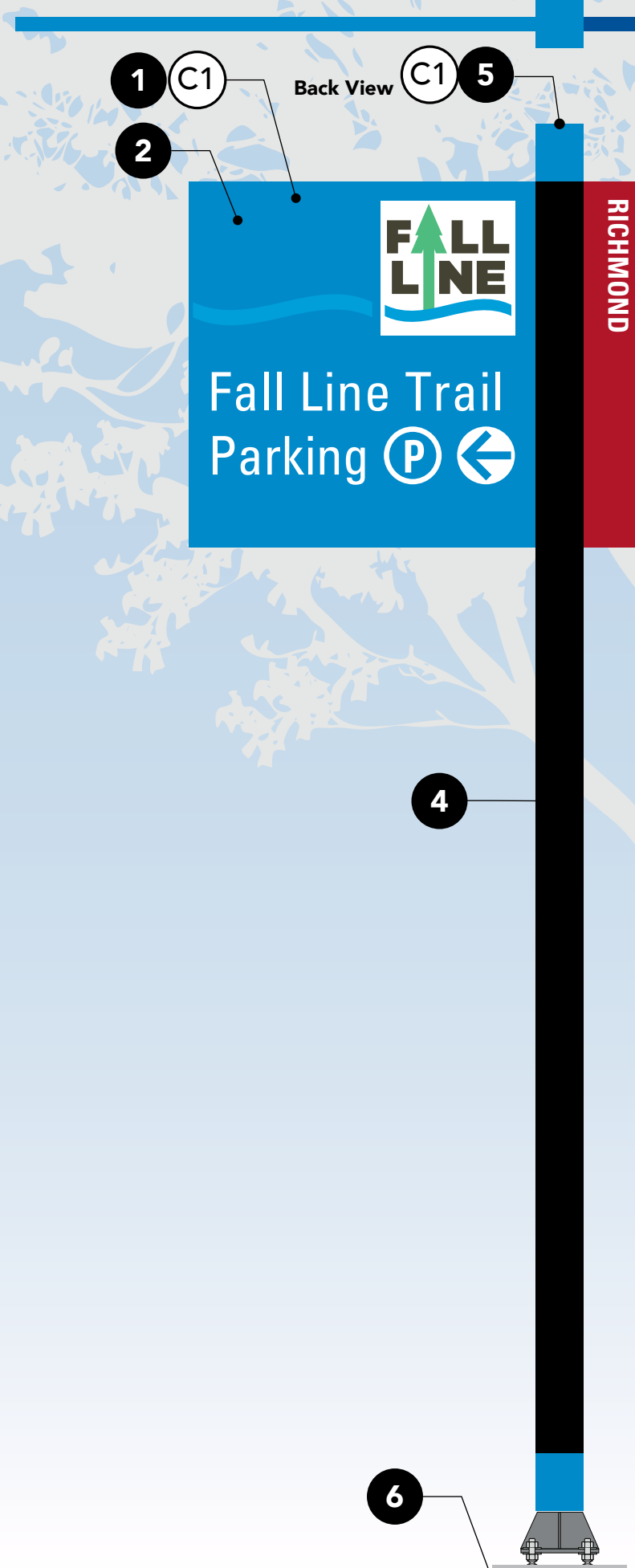

## SIGN DETAILS - SIGN U/P

### Urban Marker/ Parking Marker

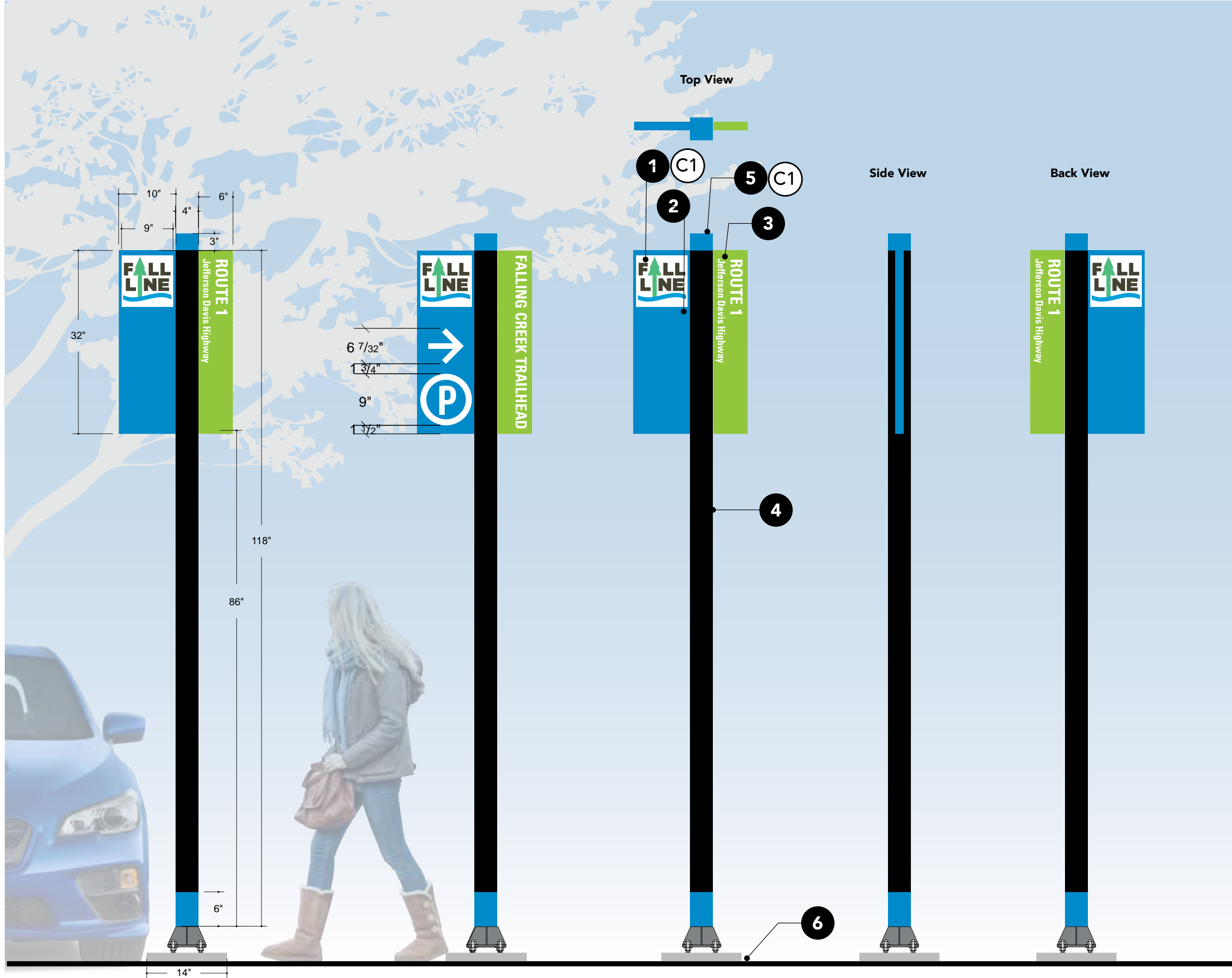

Signs to have vehicular and night visibility. Trees that obscure sign face to be trimmed.

Sign to be single or double sided.

1. 1/8" Thick aluminum face and side skins chemically welded to frame conceptual design with seamless edges. All edges and corners to be ground smooth, straight, and square with no gaps or voids. **NON OBTRUSIVE HARDWARE**

2. Colors and graphics to be digitally printed onto 3M™ High Intensity Prismatic Reflective Sheeting 3930DS (White). Apply 3M™ Electrocut™ Film Series 1170 (Clear) to seal reflective sheeting.

3. 1/8" Thick aluminum face and side skins chemically welded to frame conceptual design with seamless edges. All edges and corners to be ground smooth, straight, and square with no gaps or voids. **NON OBTRUSIVE HARDWARE**

4. 4"x 4" painted steel post with breakaway attachment.

5. Post capped with welded steel plate.

6. 3000 PSI concrete footer. The size and depth of the concrete footer shall be determined by the fabricator. The footers must be certified by engineers registered in the state Virginia.

Fabricator: Check flood levels in the area and elevate the sign as needed with a longer post.

Paint Colors:

C1. Pantone P109-7C Blue

C2. White

C3. Polyurethane Clear Coat Satin

Paint-Black

Fonts:

Univers Condensed 57

Univers Bold Condensed 67

THIS DRAWING REPRESENTS DESIGN INTENT ONLY.

Date	Revisions	Scale
8.31.23	5.23.24	3/4" = 1'

Client/Project  
CVTA, Virginia  
Wayfinding for Fall Line Trail

## SIGN DETAILS - SIGN ID

### Landmark Identification



Signs to have vehicular and night visibility. Trees that obscure sign face to be trimmed.

Sign to be single or double sided.

- 1/8" Thick aluminum face and side skins chemically welded to frame conceptual design with seamless edges. All edges and corners to be ground smooth, straight, and square with no gaps or voids. **NON OBTRUSIVE HARDWARE**
- Colors and graphics to be digitally printed onto 3M™ High Intensity Prismatic Reflective Sheeting 3930DS (White). Apply 3M™ Electrocut™ Film Series 1170 (Clear) to seal reflective sheeting.
- 1/8" Thick aluminum face and side skins chemically welded to frame conceptual design with seamless edges. All edges and corners to be ground smooth, straight, and square with no gaps or voids. **NON OBTRUSIVE HARDWARE**
- 3"x 3" painted steel post.
- Post capped with welded steel plate.
- 3000 PSI concrete footer. The size and depth of the concrete footer shall be determined by the fabricator. The footers must be certified by engineers registered in the state Virginia.

Fabricator: Check flood levels in the area and elevate the sign as needed with a longer post.

Paint Colors:  
 C1. Pantone P109-7C Blue  
 C2. White  
 C3. Polyurethane Clear Coat Satin  
 Paint-Black  
 Fonts:  
 Univers Condensed 57  
 Univers Bold Condensed 67

THIS DRAWING REPRESENTS DESIGN INTENT ONLY.

Date	Revisions	Scale
8.31.23	5.23.24	3/4" = 1'

Client/Project  
 CVTA, Virginia  
 Wayfinding for Fall Line Trail

## SIGN DETAILS - SIGN B Banner

Back View

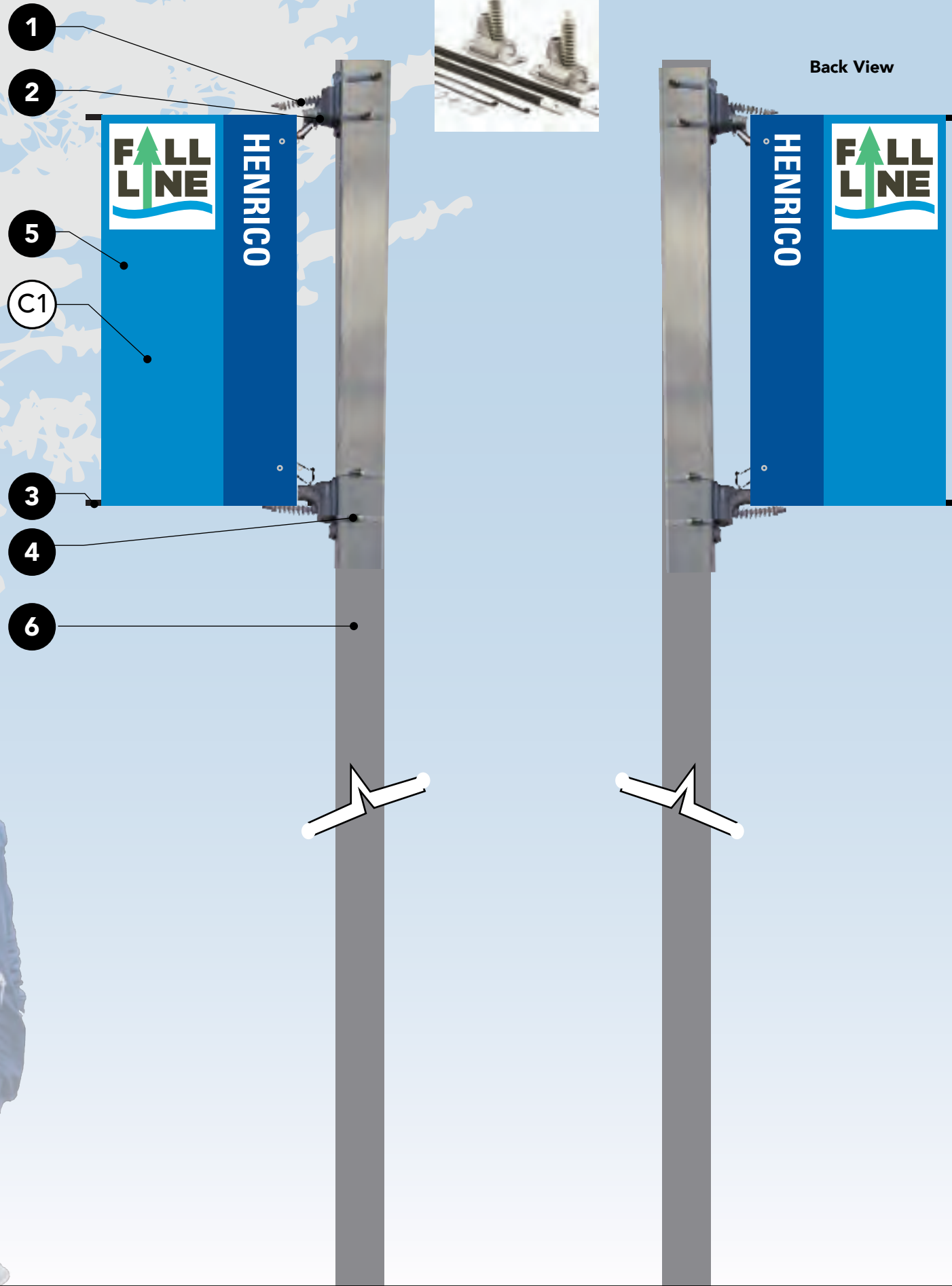
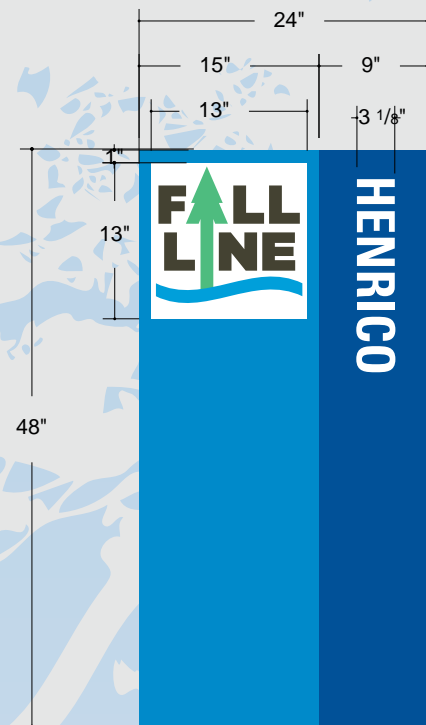

- Signs to have pedestrian & night visibility. Trees that obscure sign face to be trimmed.  
Sign to be double sided.
1. Banner cast aluminum heavy duty spring brackets.
  2. Fiberglass banner arms with tempered aluminum sleeve that adds 20% strength to rods. Arms to be resistant to cracks and corrosion
  3. 3/4 in. diameter poles with metal sleeves in the ends.
  4. Stainless steel bands with buckle.  
NOTE: this type of hardware is available at <https://britteninc.com/>  
<https://bannersaver.com/>
  5. Commercial-grade, heavy weight 18 oz, vinyl banner with pole pockets at the top and bottom. Vinyl to be mildew and water resistant, fade resistant with double needle-lock stitching and with 15 year warranty. Vinyl, printed front and back. Printing to be high resolution.
  6. Existing electrical post.

Paint Colors:

- C1. Pantone P109-7C Blue
- C2. White
- C3. Polyurethane Clear Coat Satin
- Paint-Black

Fonts:

- Univers Condensed 57
- Univers Bold Condensed 67

THIS DRAWING REPRESENTS DESIGN INTENT ONLY.

Date	Revisions	Scale
8.31.23		3/4" = 1'

Client/Project  
CVTA, Virginia  
Wayfinding for Fall Line Trail



## SIGN DETAILS - SIGN T2

### Pedestrian Trailhead / Regulatory Sign

Signs to have pedestrian and night visibility. Trees that obscure sign face to be trimmed.

Sign to be single or double sided.

1. 1/8" Thick aluminum face and side skins chemically welded to frame conceptual design with seamless edges. All edges and corners to be ground smooth, straight, and square with no gaps or voids. **NON OBTRUSIVE HARDWARE**

2. Colors and graphics to be digitally printed onto 3M™ High Intensity Prismatic Reflective Sheeting 3930DS (White). Apply 3M™ Electrocut™ Film Series 1170 (Clear) to seal reflective sheeting.

3. 1/8" Thick aluminum face and side skins chemically welded to frame conceptual design with seamless edges. All edges and corners to be ground smooth, straight, and square with no gaps or voids. **NON OBTRUSIVE HARDWARE**

4. 3" x 3" painted steel post.

5. Post capped with welded steel plate.

6. 3000 PSI concrete footer. The size and depth of the concrete footer shall be determined by the fabricator. The footers must be certified by engineers registered in the state Virginia.

\*Fabricator: Check flood levels in the area and elevate the sign as needed with a longer post.

Paint Colors:

C1. Pantone P109-7C Blue

C2. White

C3. Polyurethane Clear Coat Satin

Paint-Black

Fonts:

Univers Condensed 57

Univers Bold Condensed 67

THIS DRAWING REPRESENTS DESIGN INTENT ONLY.

Date	Revisions	Scale
8.31.23	11.6.23	3/4" = 1'
	5.23.24	

Client/Project  
CVTA, Virginia  
Wayfinding for Fall Line Trail

© 2024 AB Design, Inc.

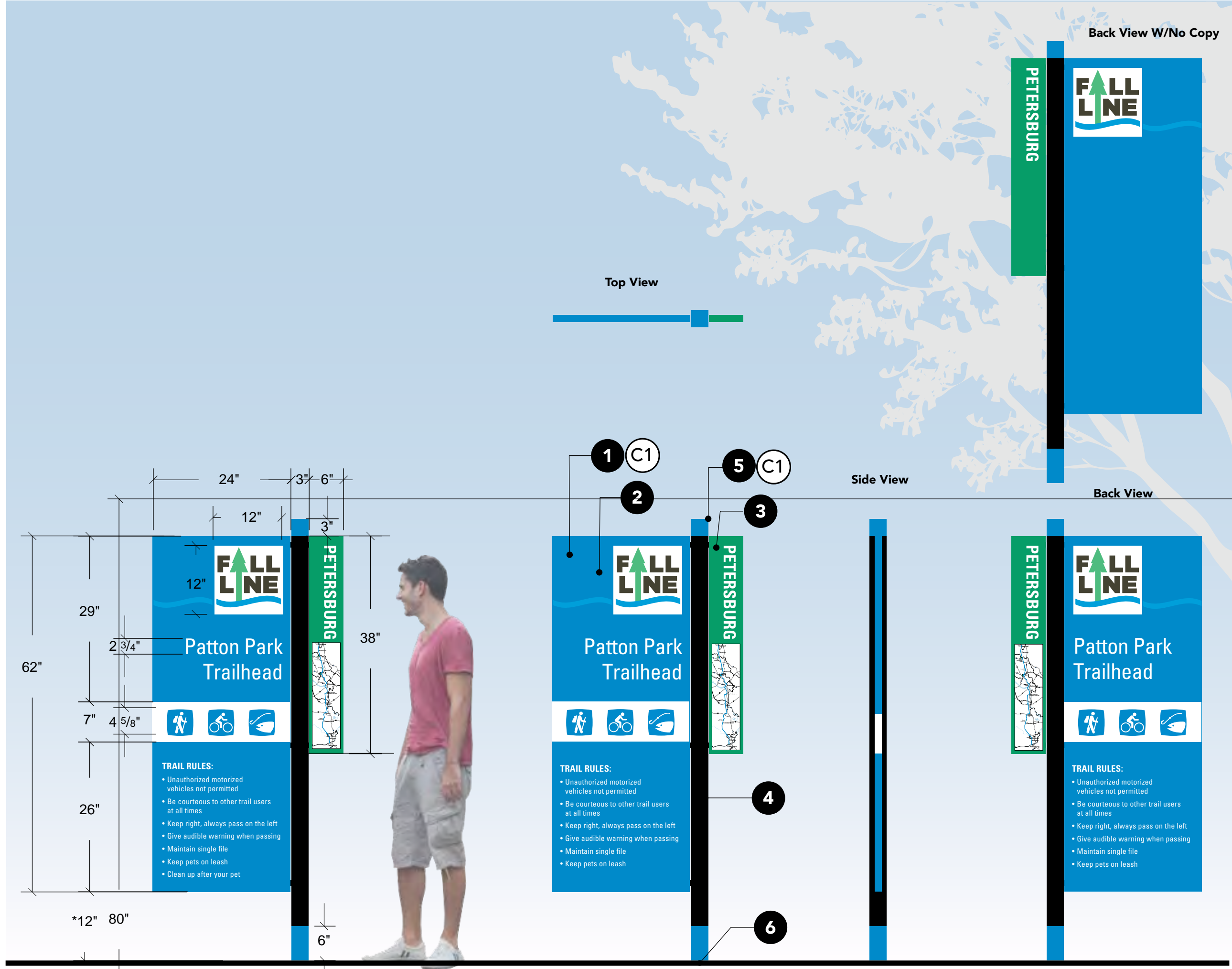

## SIGN DETAILS - SIGN P1

### Pedestrian Directional On Street

Signs to have pedestrian and night visibility. Trees that obscure sign face to be trimmed.

Sign to be single or double sided.

1. 1/4" Thick aluminum sign panel. All edges and corners to be ground smooth, straight, and square with no gaps or voids. **NON OBTUSIVE HARDWARE.**

2. Colors and graphics to be digitally printed onto 3M™ High Intensity Prismatic Reflective Sheeting 3930DS (White). Apply 3M™ Electrocut™ Film Series 1170 (Clear) to seal reflective sheeting.

3. Custom machined washer holds panels and hubs in place.

4. 3"x 3" painted steel post.

5. Post capped with welded steel plate.

6. 3000 PSI concrete footer. The size and depth of the concrete footer shall be determined by the fabricator. The footers must be certified by engineers registered in the state Virginia.

Fabricator: Check flood levels in the area and elevate the sign as needed with a longer post.

Paint Colors:

C1. Pantone P109-7C Blue

C2. White

C3. Polyurethane Clear Coat Satin

Paint-Black

Fonts:

Univers Condensed 57

Univers Bold Condensed 67

THIS DRAWING REPRESENTS DESIGN INTENT ONLY.

Date	Revisions	Scale
8.31.23	11.6.23	3/4" = 1'
	5.23.24	

Client/Project  
CVTA, Virginia  
Wayfinding for Fall Line Trail

© 2024 AB Design, Inc.

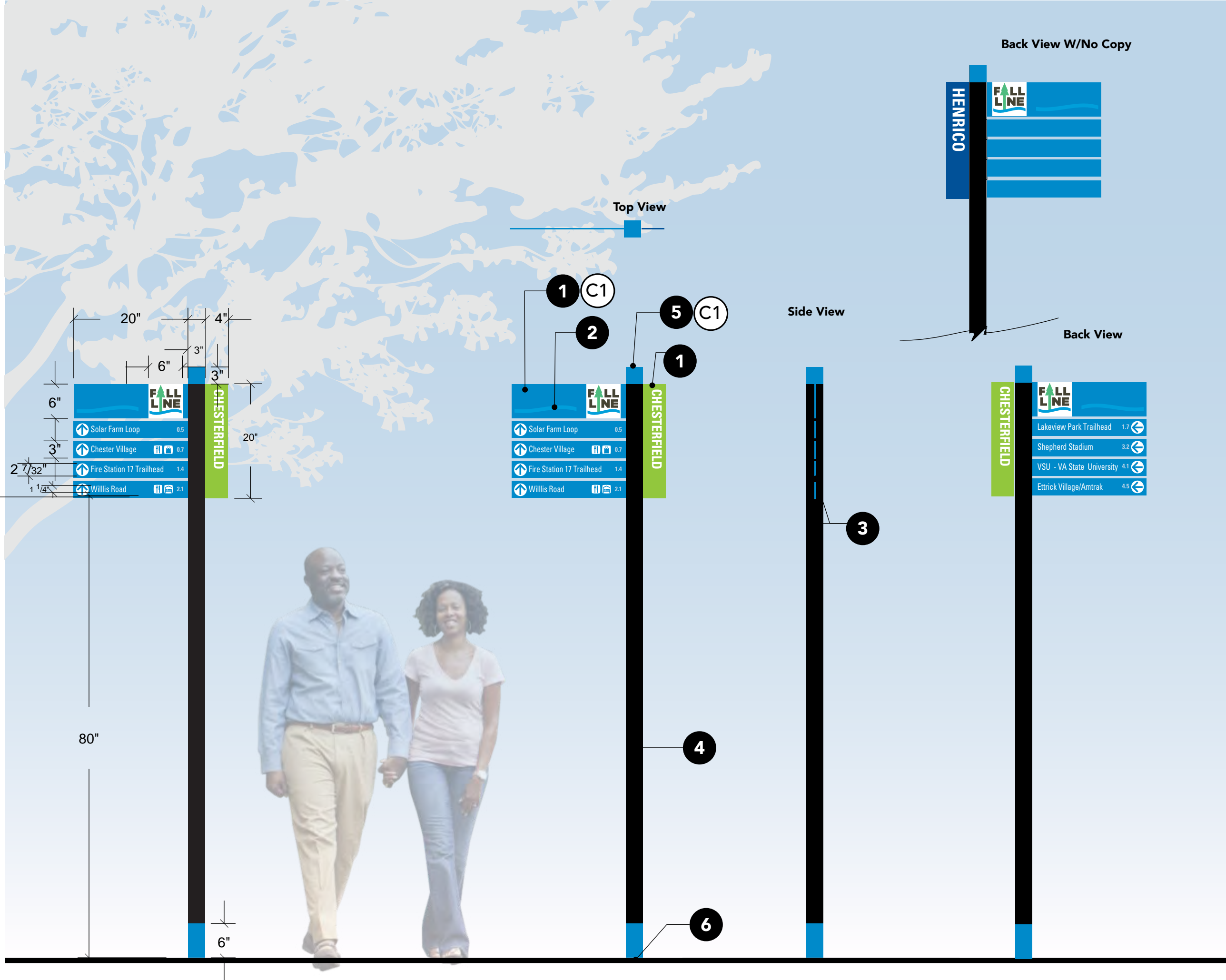





## SIGN DETAILS - SIGN P2

### Pedestrian Directional Off Street

- Sign to be single or double sided.
- 1/4" Thick aluminum sign panel. All edges and corners to be ground smooth, straight, and square with no gaps or voids. **NON OBTRUSIVE HARDWARE.**
  - Colors and graphics to be digitally printed onto 3M™ High Intensity Prismatic Reflective Sheeting 3930DS (White). Apply 3M™ Electrocut™ Film Series 1170 (Clear) to seal reflective sheeting.
  - Custom machined washer holds panels and hubs in place.
  - 3"x 3" painted steel post.
  - Post capped with welded steel plate.
  - 3000 PSI concrete footer. The size and depth of the concrete footer shall be determined by the fabricator. The footers must be certified by engineers registered in the state Virginia.

Fabricator: Check flood levels in the area and elevate the sign as needed with a longer post.

Paint Colors:  
 C1. Pantone P109-7C Blue  
 C2. White  
 C3. Polyurethane Clear Coat Satin  
 Paint-Black  
 Fonts:  
 Univers Condensed 57  
 Univers Bold Condensed 67

THIS DRAWING REPRESENTS DESIGN INTENT ONLY.

Date	Revisions	Scale
8.31.23	11.6.23 1.5.24	3/4" = 1'

Client/Project  
 CVTA, Virginia  
 Wayfinding for Fall Line Trail

© 2024 AB Design, Inc.

Back View W/No Copy

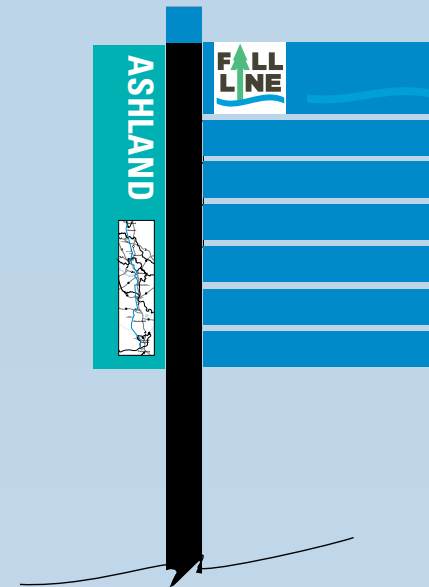

Top View



Side View

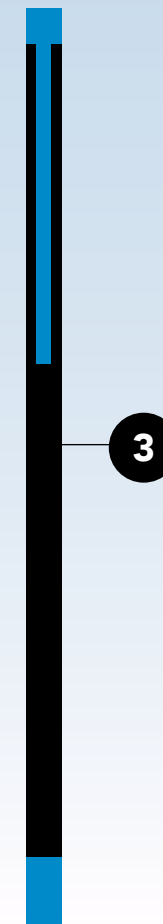

Back View

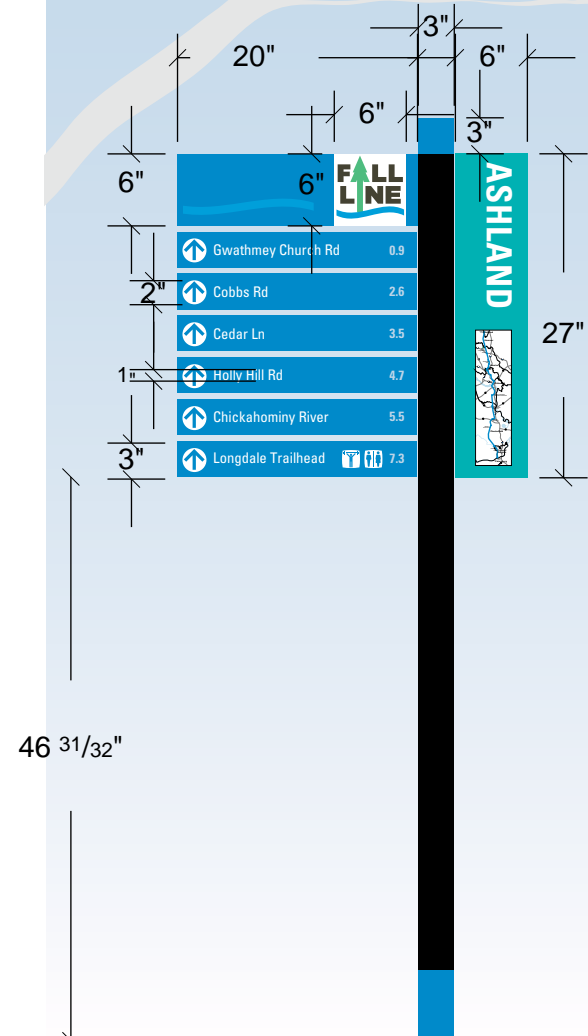
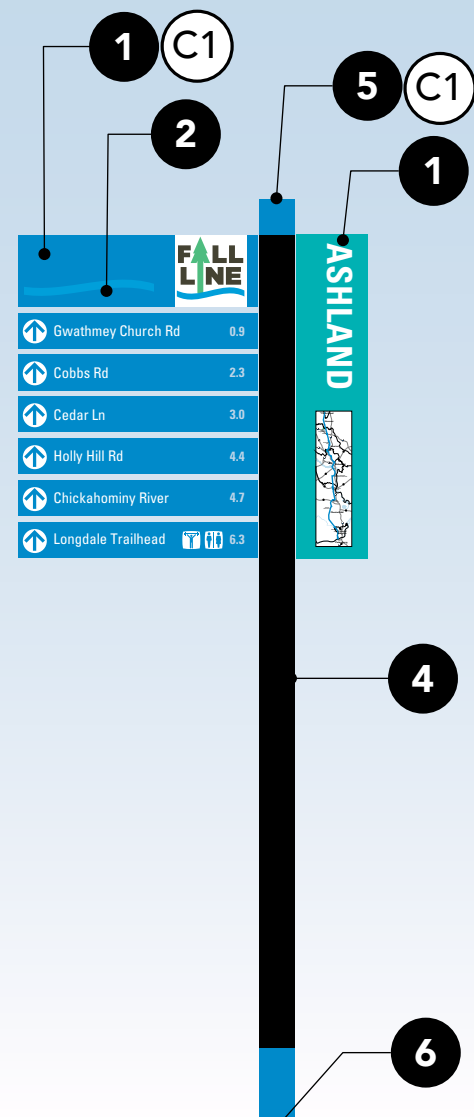
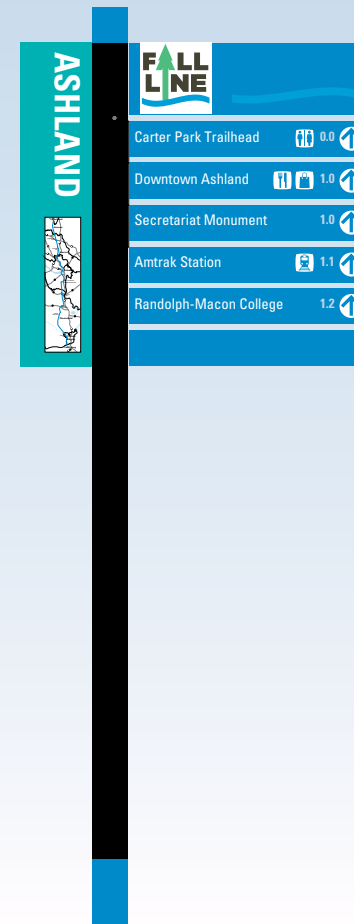

## SIGN DETAILS - SIGN M1 & M2

### Mile Marker

Signs to have pedestrian, vehicular and night visibility. Trees that obscure sign face to be trimmed.

Sign to be double sided.

1. 1/8" Thick aluminum face and side skins chemically welded to frame conceptual design with seamless edges. All edges and corners to be ground smooth, straight, and square with no gaps or voids. NON OBTRUSIVE HARDWARE.

2. Colors and graphics to be digitally printed onto 3M™ High Intensity Prismatic Reflective Sheeting 3930DS (White). Apply 3M™ Electrocut™ Film Series 1170 (Clear) to seal reflective sheeting.

3. 1/8" Thick aluminum face and side skins chemically welded to frame conceptual design with seamless edges. All edges and corners to be ground smooth, straight, and square with no gaps or voids. NON OBTRUSIVE HARDWARE.

4. 3"x 3" painted steel post.

5. Post capped with welded steel plate.

6. 3000 PSI concrete footer. The size and depth of the concrete footer shall be determined by the fabricator. The footers must be certified by engineers registered in the state Virginia.

Fabricator: Check flood levels in the area and elevate the sign as needed with a higher base.

Paint Colors:

C1. Pantone P109-7C Blue

C2. White

C3. Polyurethane Clear Coat Satin

Paint-Black

Fonts:

Univers Condensed 57

Univers Bold Condensed 67

THIS DRAWING REPRESENTS DESIGN INTENT ONLY.

Date	Revisions	Scale
8.31.23	11.6.23	3/4" = 1'

Client/Project  
CVTA, Virginia  
Wayfinding for Fall Line Trail

© 2024 AB Design, Inc.

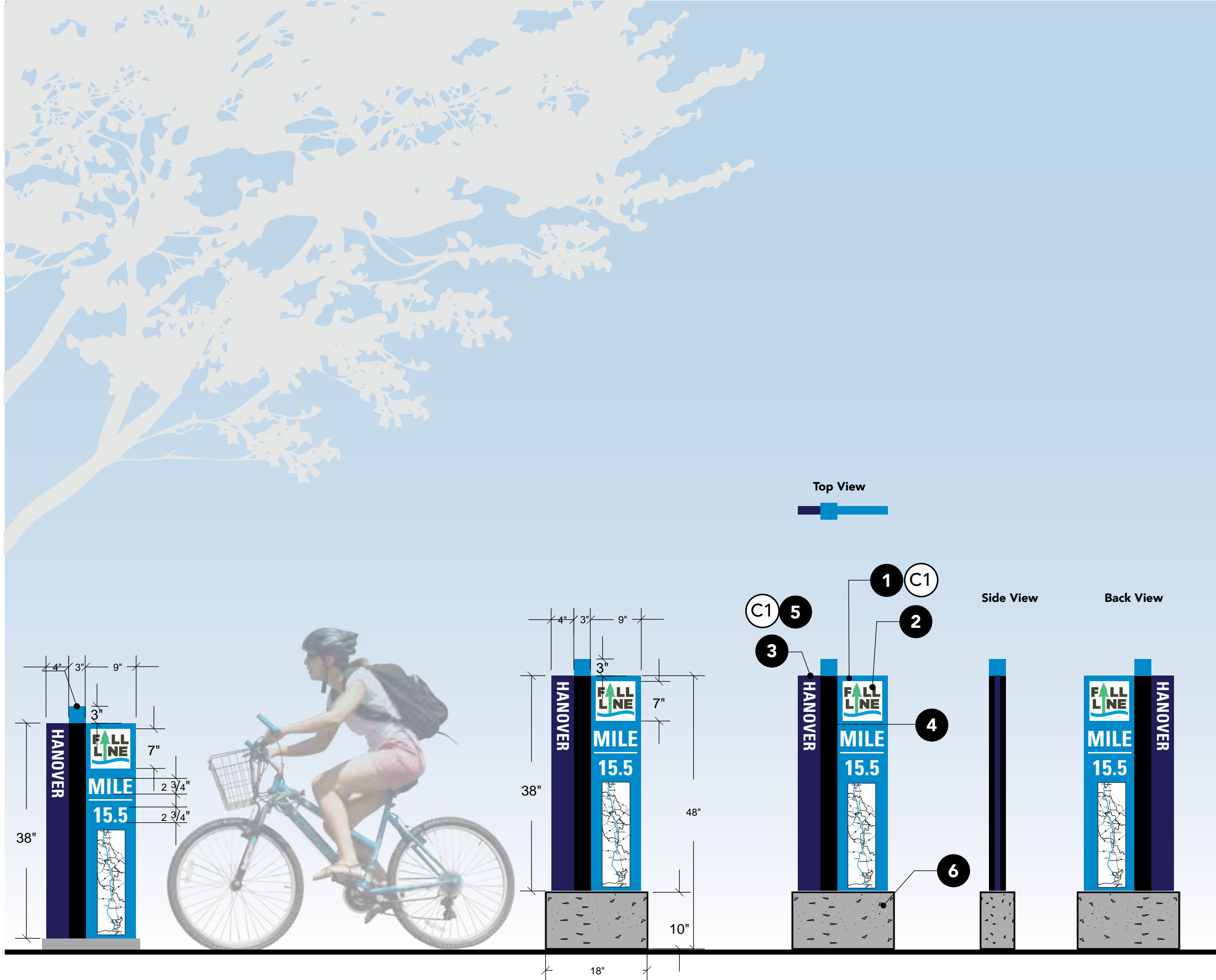

## SIGN DETAILS - SIGN W

### Warning Signs

Signs to have pedestrian and night visibility. Trees that obscure sign face to be trimmed.

Sign to be double sided.

1. 1/8" Thick aluminum face and side skins chemically welded to frame conceptual design with seamless edges. All edges and corners to be ground smooth, straight, and square with no gaps or voids. NON OBTRUSIVE HARDWARE

2. Colors and graphics to be digitally printed onto 3M™ High Intensity Prismatic Reflective Sheeting 3930DS (White). Apply 3M™ Electrocut™ Film Series 1170 (Clear) to seal reflective sheeting.

3. Post capped with welded steel plate.

4. 3" x 3" painted steel post.

5. 3000 PSI concrete footer. The size and depth of the concrete footer shall be determined by the fabricator. The footers must be certified by engineers registered in the state Virginia.

Fabricator: Check flood levels in the area and elevate the sign as needed with a longer post.

Paint Colors:

C1. Pantone P109-7C Blue

C2. White

C3. Polyurethane Clear Coat Satin Paint-Black

Fonts:

Univers Condensed 57

Univers Bold Condensed 67

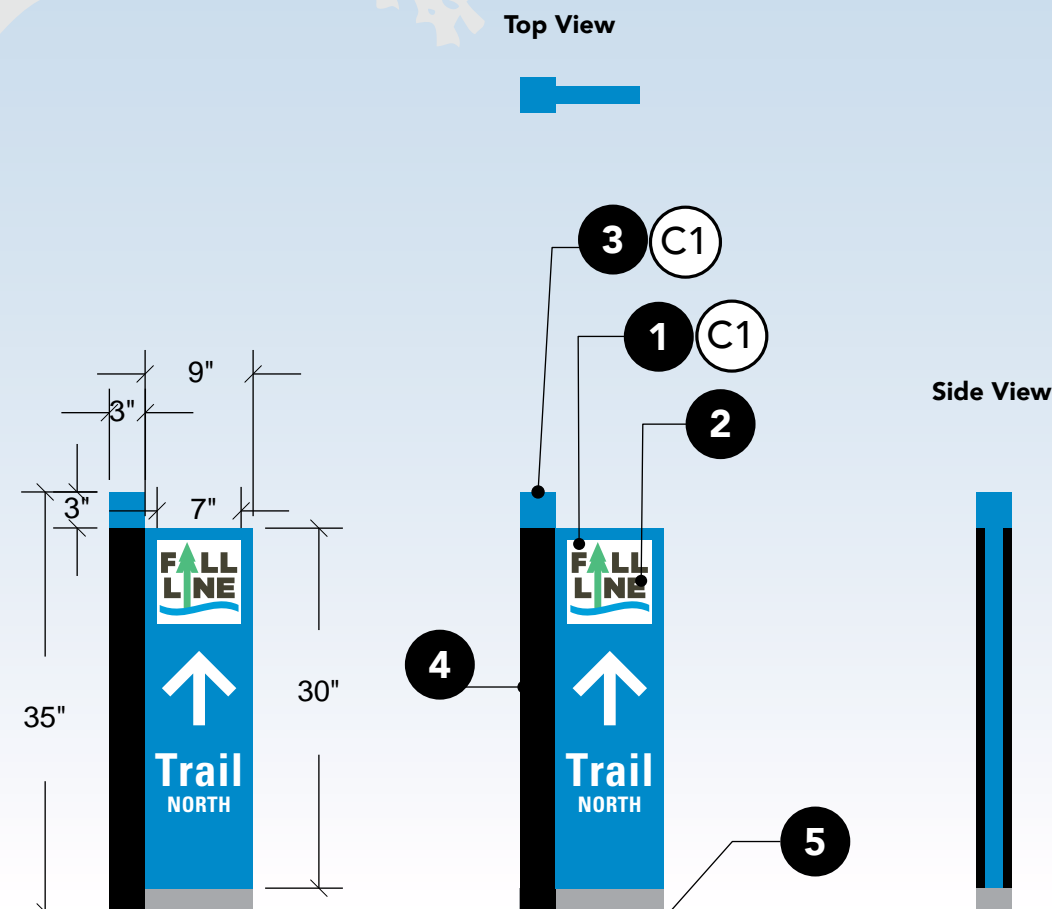

THIS DRAWING REPRESENTS DESIGN INTENT ONLY.

Date	Revisions	Scale
8.31.23		3/4" = 1'

Client/Project  
CVTA, Virginia  
Wayfinding for Fall Line Trail



### SIGN DETAILS - SIGN VI

Vinyl Decal

### SIGN PL1&2 Metallic Plates

To be applied to existing light poles or any other existing vertical element that will allow for it. Sizes for the PL1 and VI square can be 6"x6", 7"x7", 9"x9" and 12"x12". Sizes for the PL2 and VI rectangular can be 3"x4 1/2", 4"x6" and 6"x9".

Material for VI to be exterior grade digitally printed vinyl.

Material for PL1 & PL2 to be .080 Aluminum pre-sheathed in white vinyl; routed corners/shapes, with rounded edges.

PL2 to have vinyl applied to both sides, or Direct Print with UV Clear Coat.

Sign post cap (Round, Square or U-Channel)  
Available locally through Traffic Safety Supply Co. 503.235.8531 - 800.547.8518  
<https://www.tssco.com/contact/>



Round Pipe Cap  
2-3/8" Cap  
3.25" receiver



Square Post Cap  
2" Cap  
3.25" receiver  
Flat #16504402



U-Channel Post Cap  
180 Degree Cap  
3.25" receiver  
Flat #16504615



4" Wood Post Cap  
4"X4" Cap  
3.25" receiver  
Flat #16503800

THIS DRAWING REPRESENTS DESIGN INTENT ONLY.

Date	Revisions	Scale
8.31.23	9.15.23 11.6.23	3/4" = 1'

Client/Project  
CVTA, Virginia  
Wayfinding for Fall Line Trail

PL1  
Square plate  
.080 aluminum w/ applied vinyl;  
or digital print on vinyl



VI  
Vertical vinyl decal  
Digital print on vinyl



VI  
Post wrap vinyl  
Square or rectangular;  
digital print on vinyl;  
measure and cut to size  
before applying



PL2  
Rectangular Plate  
Sign Post Cap -  
.080 aluminum;  
on post

#### Color Options





## SIGN DETAILS - SIGN G

Identification:  
Ground Decals

Sign G: to be applied to the ground as vinyl or a solid material embedded on the surface of the trail. Sizes and materials to vary by location. 16"x16" and 24"x24".

Material to be ORACAL® 751, 2-mil apt Minimum Life Expectancy of 8 years with a non skid over laminate to be ORAGUARD® 255AS 6.5 mil, Matte transparent with a raised, skid-resistant, textured surface or similar.

Sign S: to be stenciled or painted directly into a surface. Sizes and materials to vary by location.

Other alternatives to include: metal medallions, thermoplastic, stamped concrete, and tile mosaics.

THIS DRAWING REPRESENTS DESIGN INTENT ONLY.

Date	Revisions	Scale
8.31.23	9.15.23 11.6.23	NTS

Client/Project  
CVTA, Virginia  
Wayfinding for Fall Line Trail

© 2024 AB Design, Inc.



Sign Type G2  
Ground Stencil on Pavement

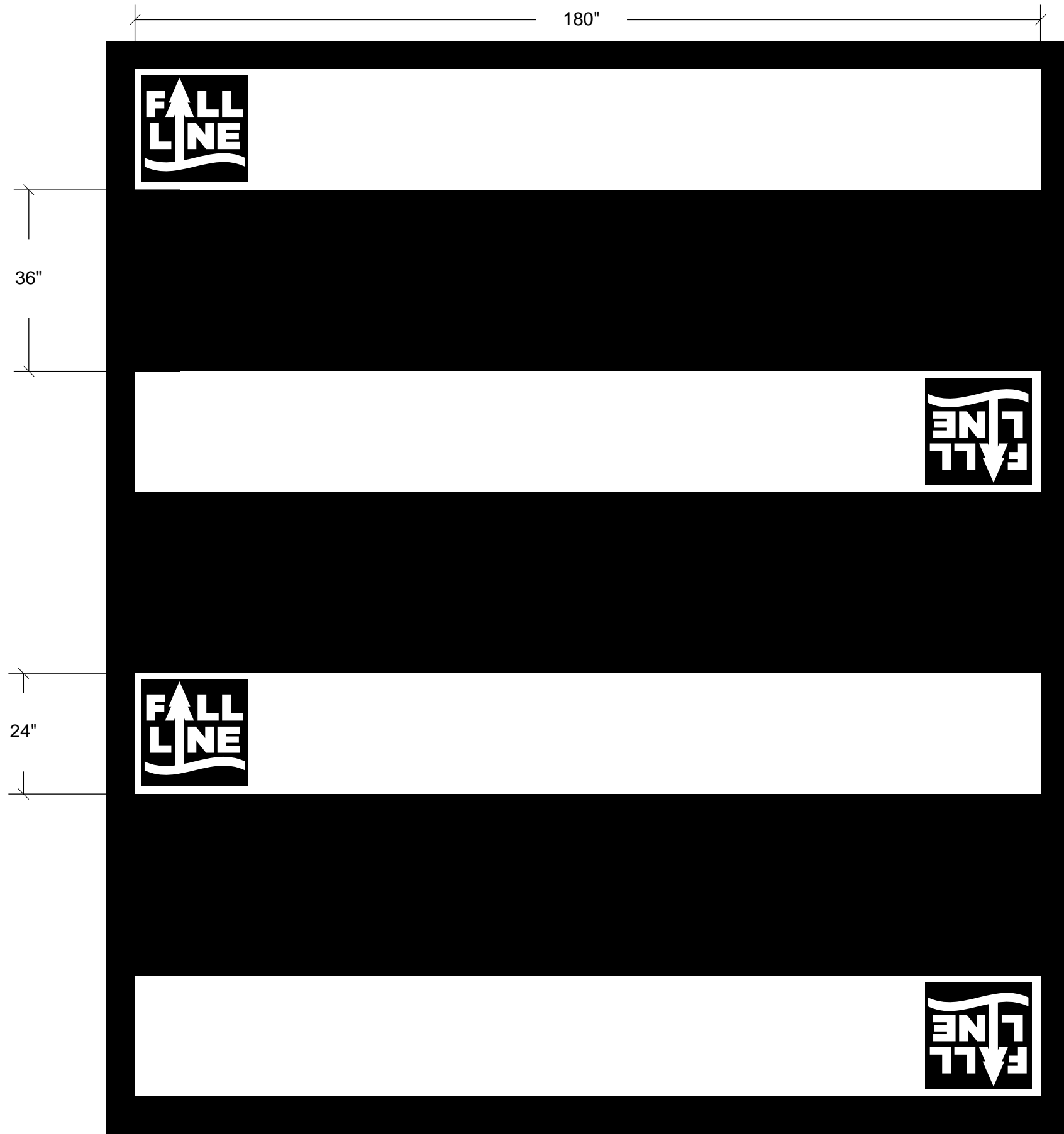

Branded Crosswalk



SIGN DETAILS - **SIGN G2**  
Ground Stencil on Pavement

Stencil on pavement to be used at the beginning of the trail after a road crossing as well as on branded crossings.

THIS DRAWING REPRESENTS DESIGN INTENT ONLY.

Date	Revisions	Scale
1.5.24		3/4"=1'

Client/Project  
CVTA, Virginia  
Wayfinding for Fall Line Trail

© 2024 AB Design, Inc.

## SIGN DETAILS - Typical Detail for Cantilevered Signs

Sign to be double sided.

1. Fabricated 1/8" Thick aluminum face and side skins chemically welded to frame conceptual design with seamless edges. All edges and corners to be ground smooth, straight, and square with no gaps or voids. **NON OBTRUSIVE HARDWARE**

2. 4" x 4" painted steel post.

3. Post capped with welded steel plate.

4. 1" x 1" x 11 Gauge steel tube welded to post.

5. 1" x 1" x 1/8" thick wall aluminum tube frame, welded construction.

6. Sign box attached to steel arms with 10-24 S.S. countersunk screws.

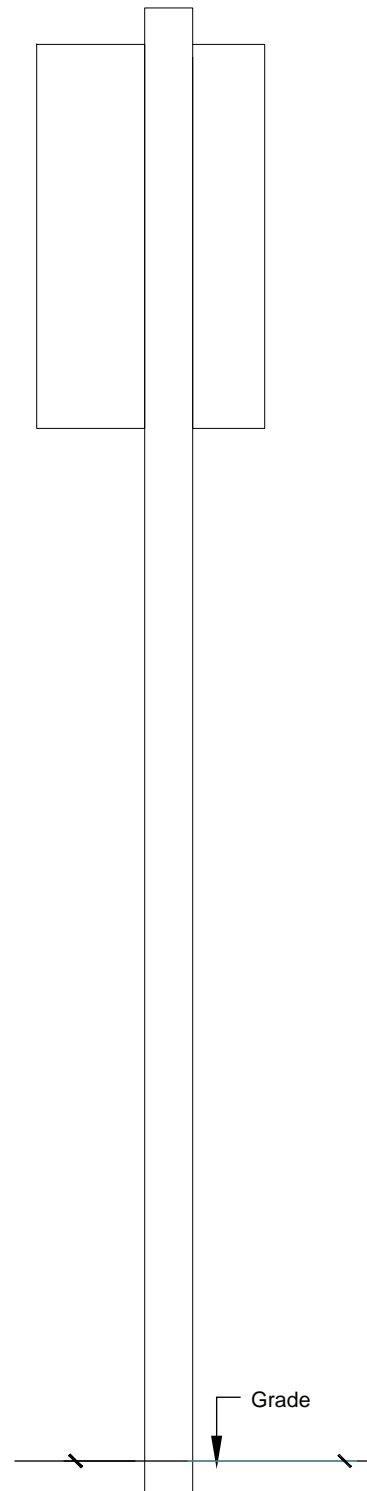

Elevation

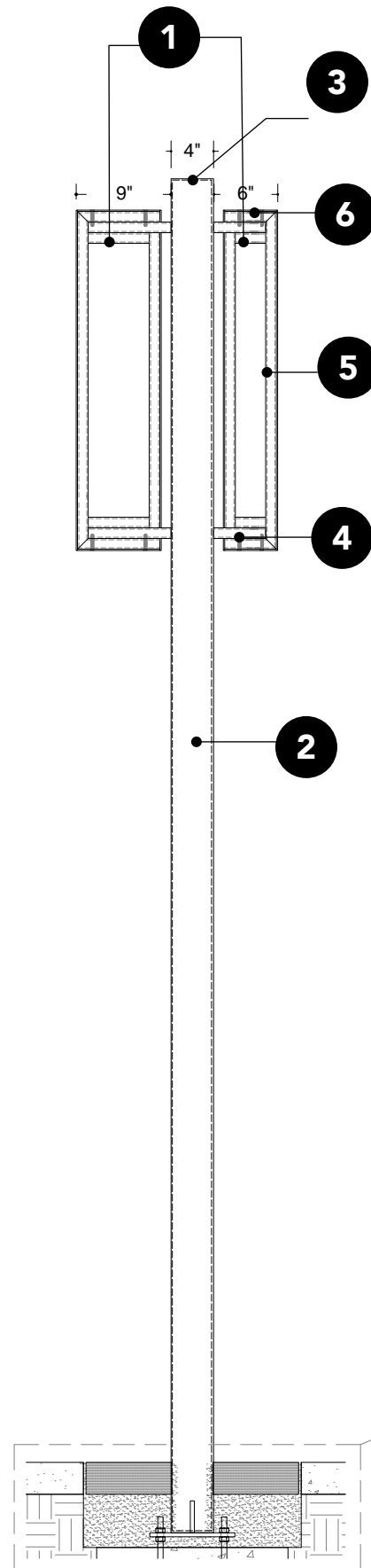

Elevation (no face)

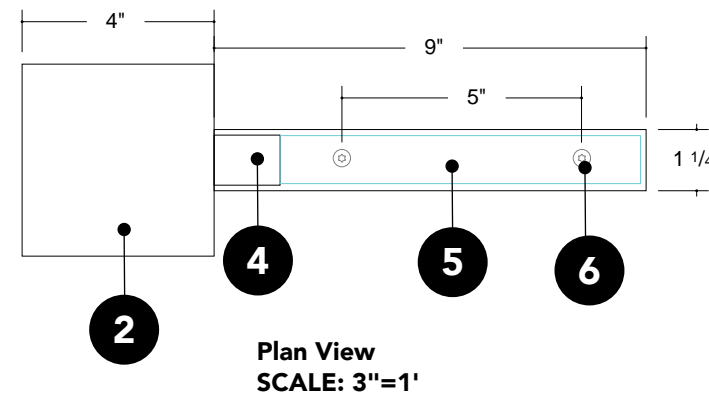

Plan View  
SCALE: 3"=1'

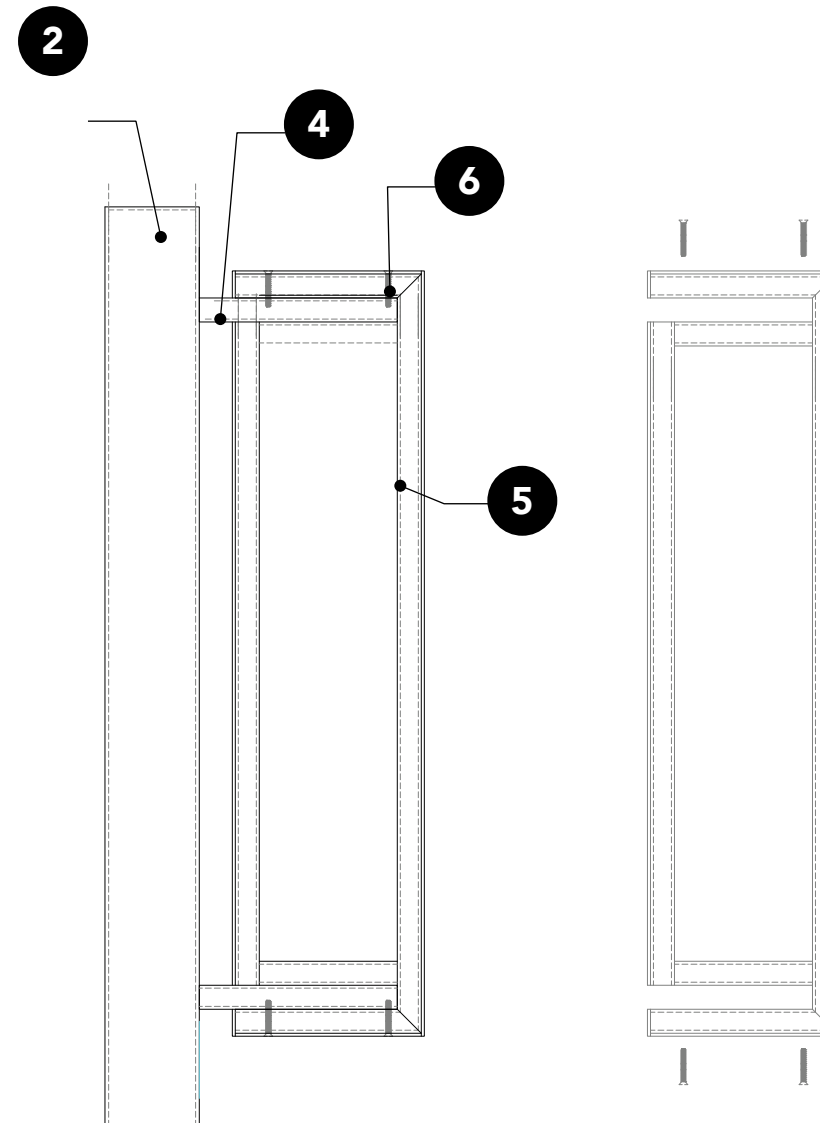

Elevation Blow Up  
Scale 1 1/2"=1'

SCALE: 1 1/2" = 1'

THIS DRAWING REPRESENTS DESIGN INTENT ONLY.

Date	Revisions	Scale
9.15.23		3/4"=1'

Client/Project  
CVTA, Virginia  
Wayfinding for Fall Line Trail

© 2024 AB Design, Inc.

## SIGN DETAILS - Typical Detail for Cantilevered Signs With Inserts 1

Sign to be double sided.

1. Fabricated 1/8" Thick aluminum face and side skins chemical welded to frame conceptual design with seamless edges. All edges and corners to be ground smooth, straight, and square with no gaps or voids. NON OBTRUSIVE HARDWARE

2. 3"x 3" painted steel post.

3. Post capped with welded steel plate.

4. 1"x 1"x 11 Gauge steel tube welded to post.

5. 1"x 1"x 1/8" thick wall aluminum tube frame, welded construction.

6. Sign box attached to steel arms with 10-24 S.S. countersunk screws.

7. U chanel rails for removable inserts.

8. 1/8" Thick aluminum removable inserts.

9. Side encap/ panel retainer to secure inserts in place, attached with screws.

Insure that panels have a snug but not tight fit into tracks so that paint will not get scratched as panels are inserted or removed.

THIS DRAWING REPRESENTS DESIGN INTENT ONLY.

Date	Revisions	Scale
9.15.23	5.29.24	3/4"=1'

Client/Project  
CVTA, Virginia  
Wayfinding for Fall Line Trail

© 2024 AB Design, Inc.

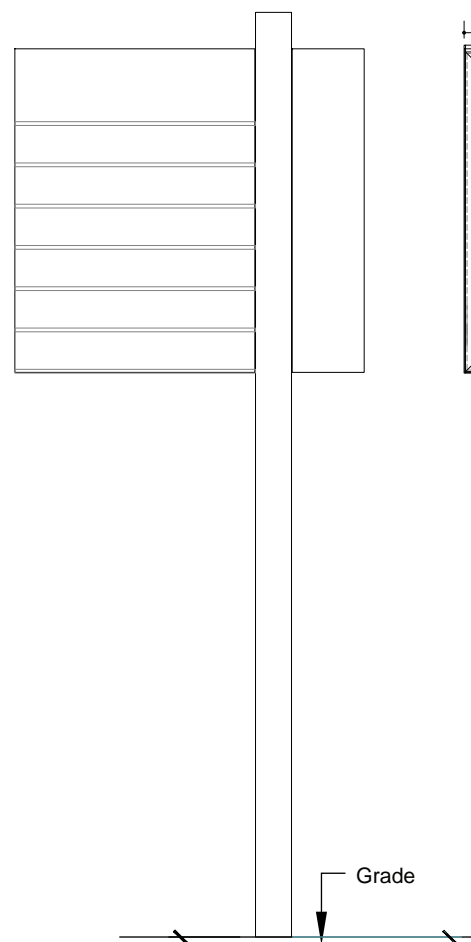
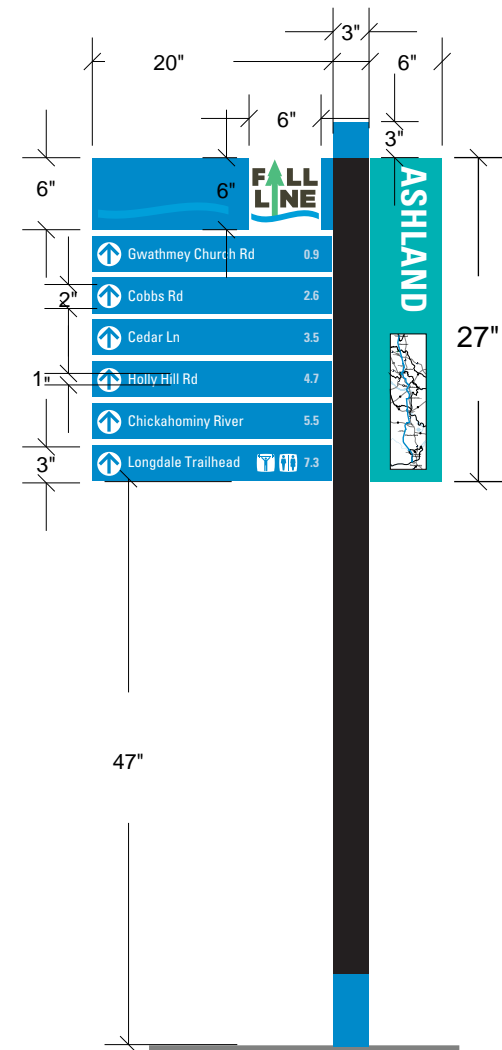
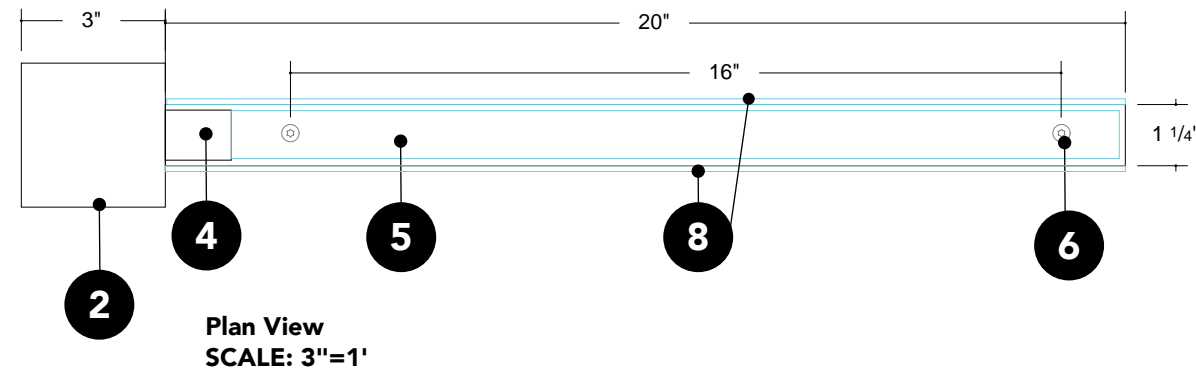

**Elevation**

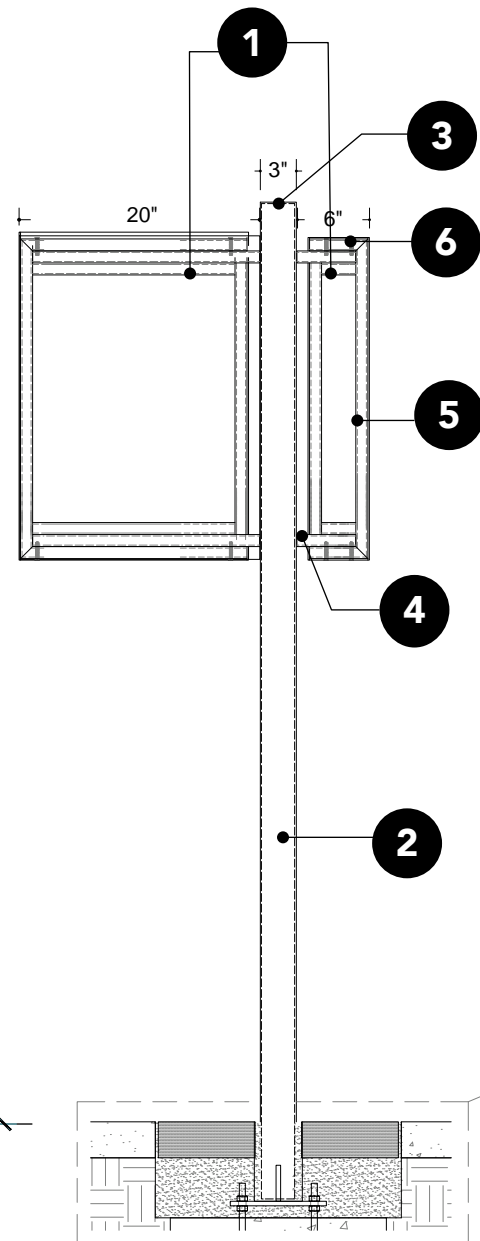

**Elevation (no face)**

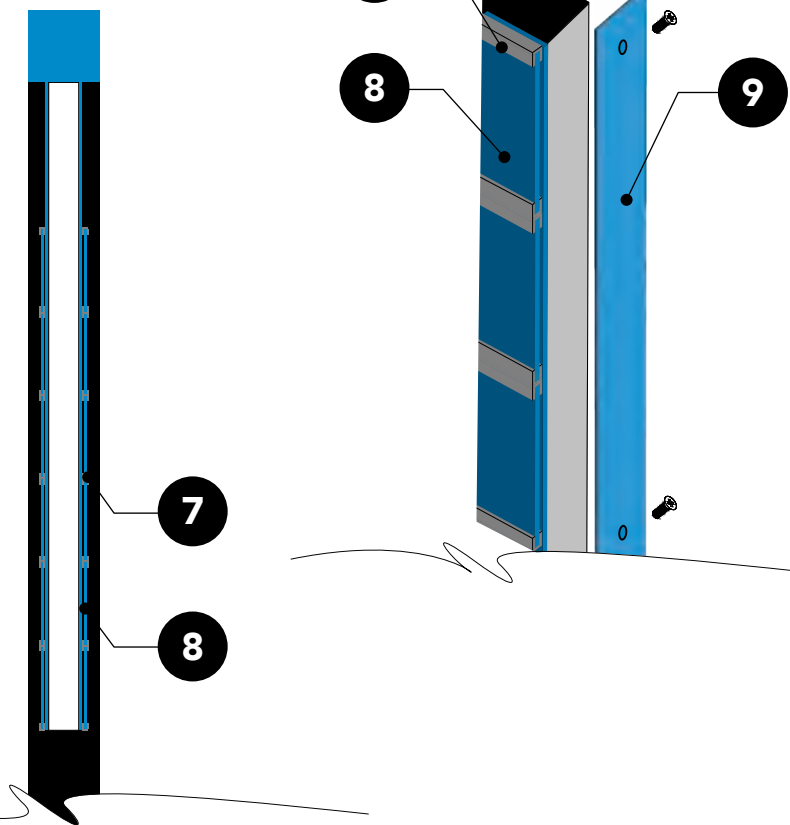

**Side View**  
Scale 1 1/2"=1'



## SIGN DETAILS - Typical

### Detail for Cantilevered Signs With Inserts 2

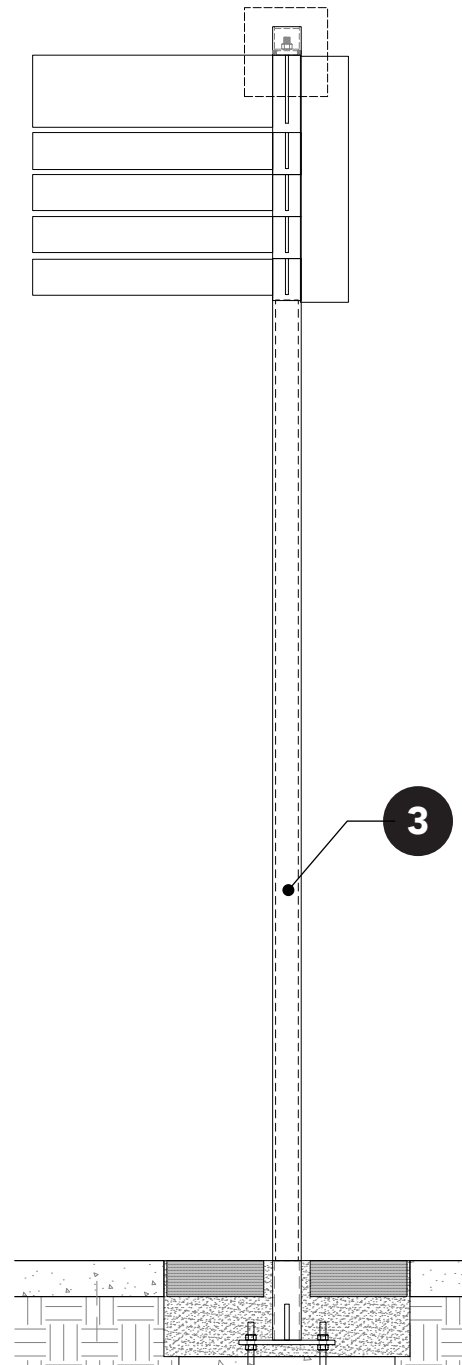
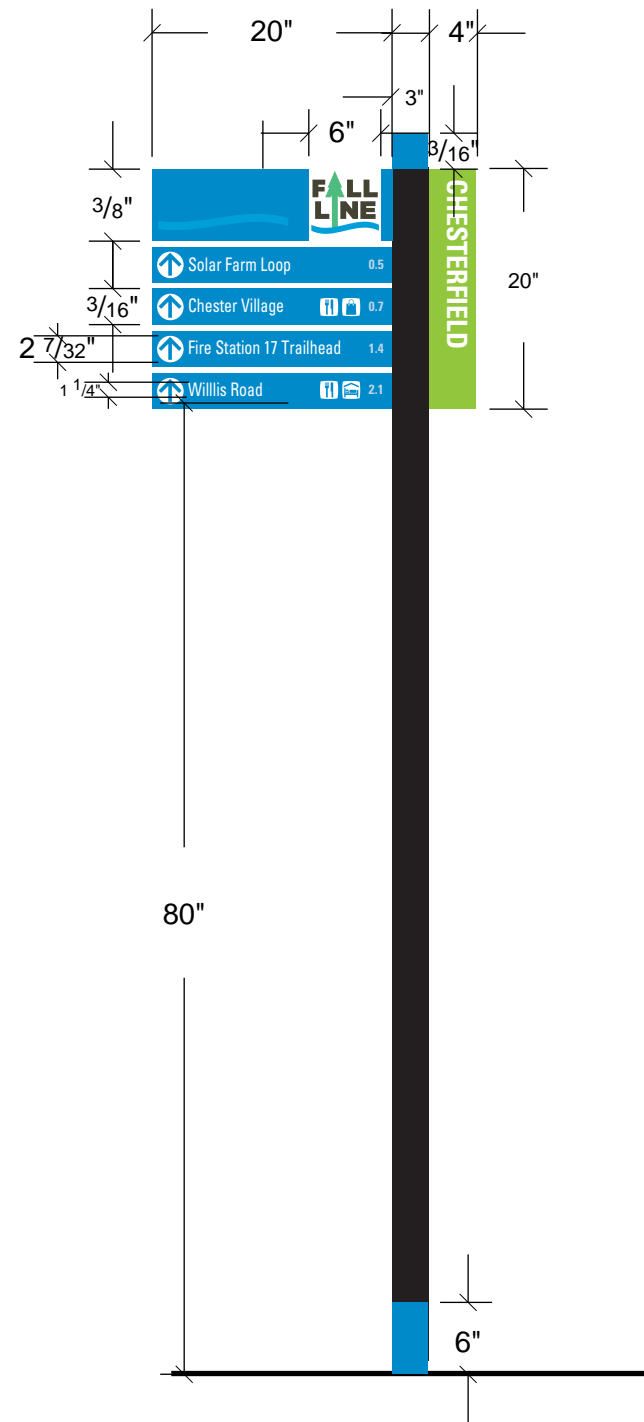

Elevation

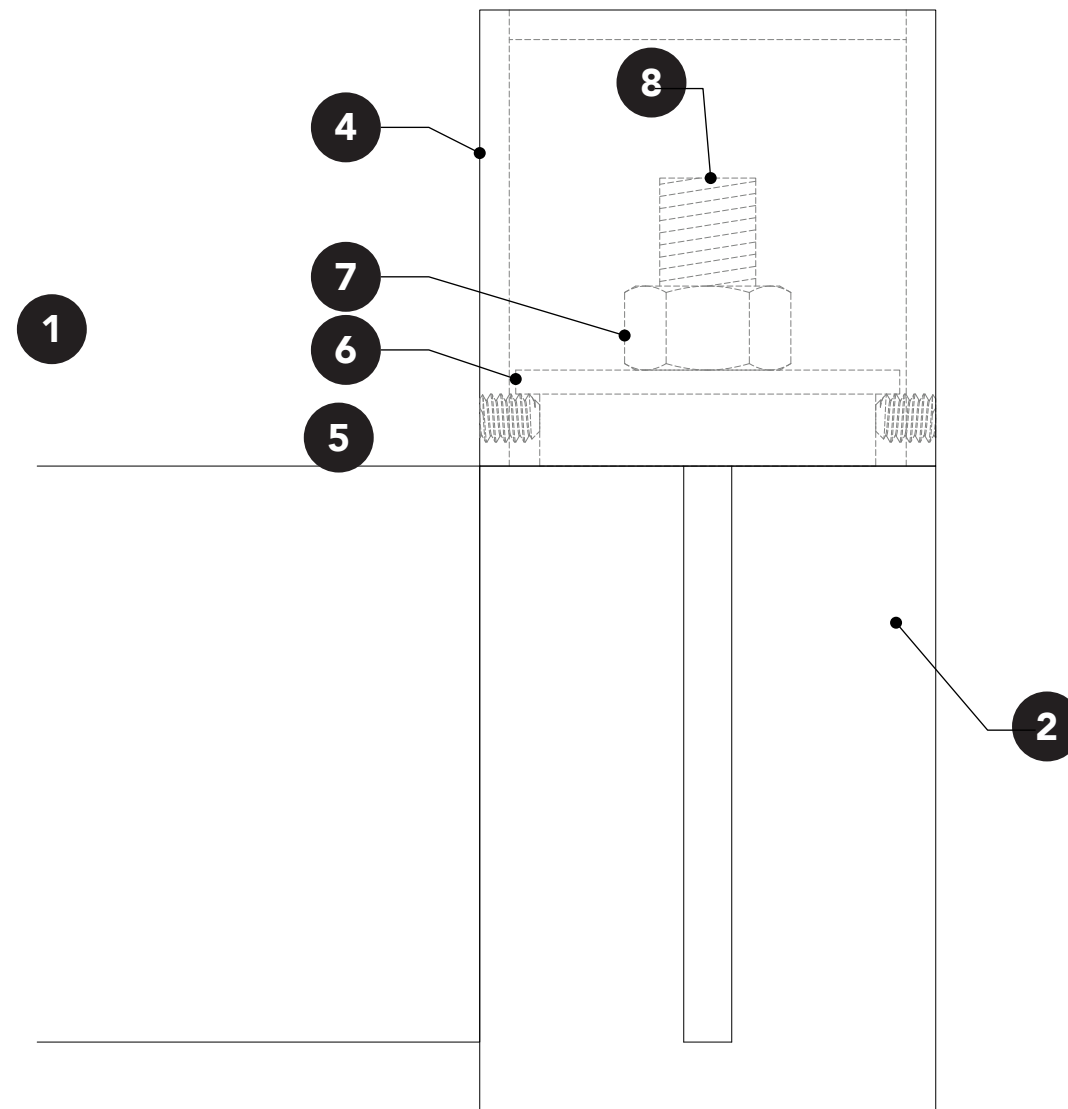

Elevation Blow Up  
Scale: Full Size

1. 1/4" thick aluminum sign panel.
2. Custom machined aluminum hub.
3. 3"x3" steel post.
4. Post capped with welded steel plate.
5. Cap secured with 1/4"-20x5/16" set screws. Set Screws to be on opposite side of walking person graphics.
6. Custom machined washer holds panels and hubs in place.
7. Washer secured with 1/2" nut and locking washer.
8. 1/2" S.S. threaded rod extends up from post, hubs slide over this.

THIS DRAWING REPRESENTS DESIGN INTENT ONLY.

Date	Revisions	Scale
9.15.23		3/4"=1'

Client/Project  
CVTA, Virginia  
Wayfinding for Fall Line Trail

## SIGN DETAILS - Typical Detail for Breakaway

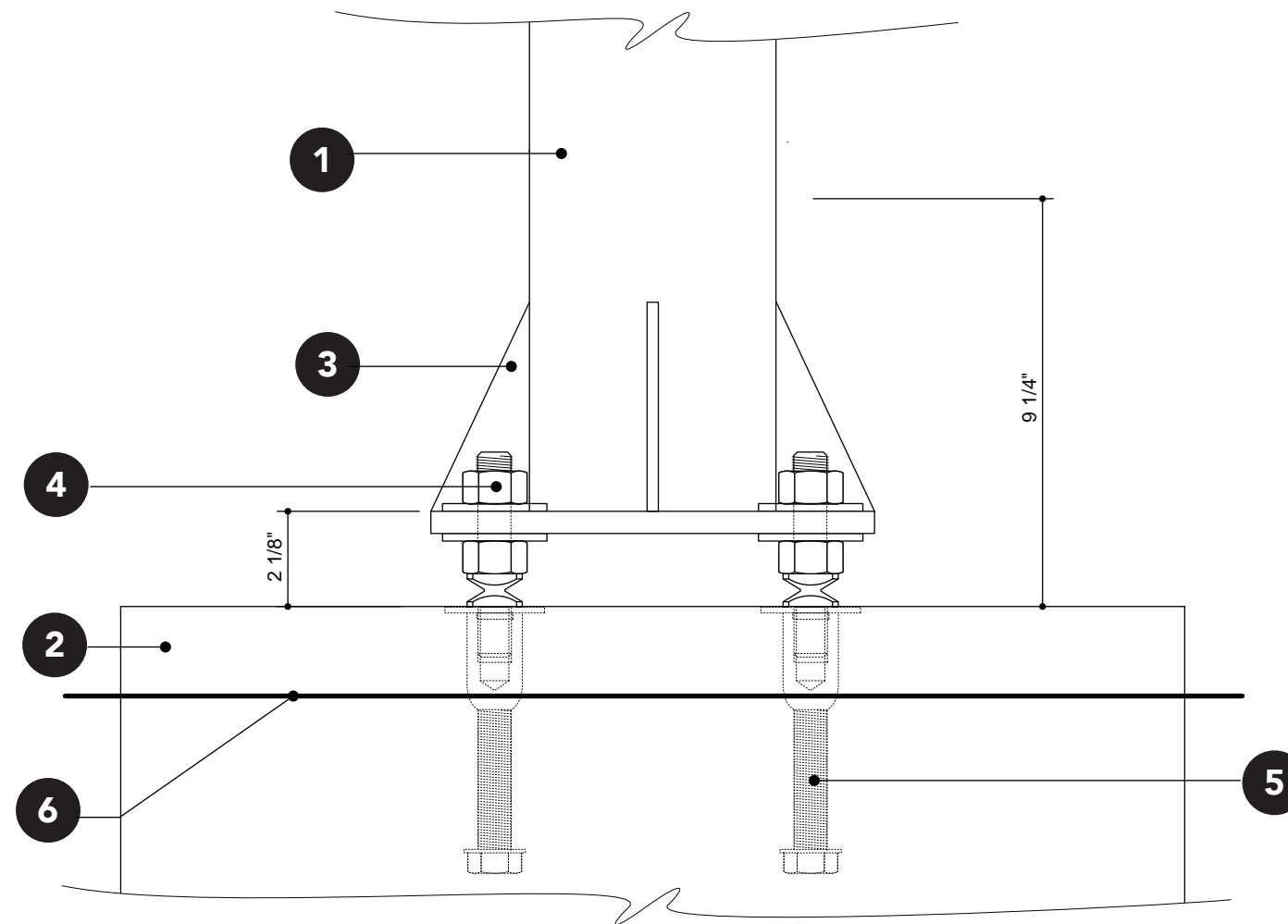

1. Square painted post.
2. 3000 psi concrete foundation cylinder.
3. Welded flange and mounting plate.
4. FHWA-approved Transpo PoleSafe® breakaway supports (or equivalent) to be attached to J-bolts below and base flange above. Coupling to be engineered and installed according to manufacturer's specifications.
5. Galvanized "J" anchor bolts.
6. Grade

THIS DRAWING REPRESENTS DESIGN INTENT ONLY.

Date	Revisions	Scale
9.15.23		3"=1'

Client/Project  
CVTA, Virginia  
Wayfinding for Fall Line Trail

© 2024 AB Design, Inc.

**SIGN DETAILS - Typical**  
 Detail for Pedestrian  
 Signs Base

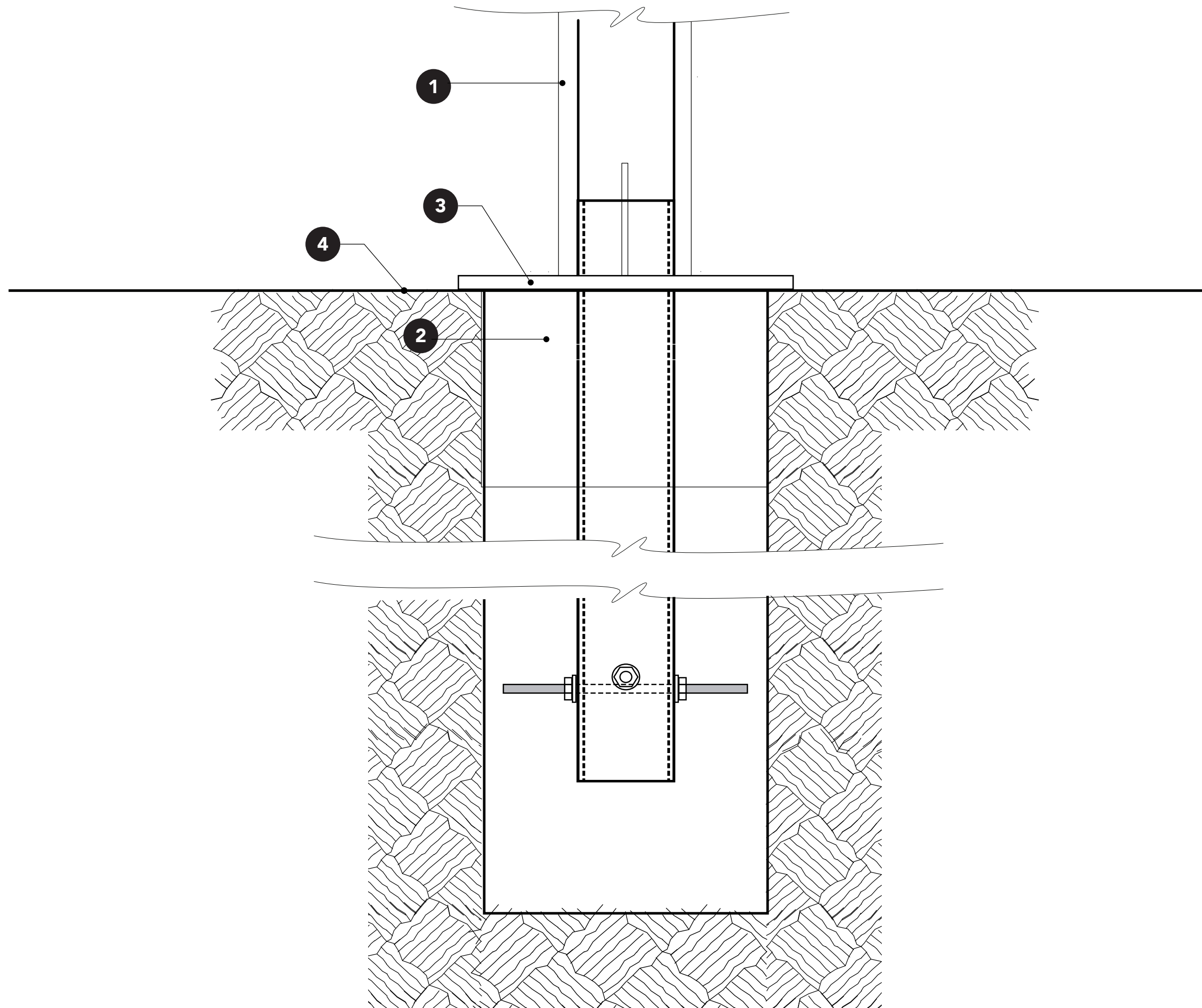

1. Square painted post.
2. 3000 psi concrete foundation cylinder 12" Ø .
3. 14" cover to cover 12" Ø footer so that no concrete patching is required on signs installed on concrete pavers.
4. Grade

THIS DRAWING REPRESENTS DESIGN INTENT ONLY.

Date	Revisions	Scale
9.15.23		3"=1'

Client/Project  
 CVTA, Virginia  
 Wayfinding for Fall Line Trail



---

# Placement Guidelines

---

### Vehicular Guide Placement - Right Side of Street

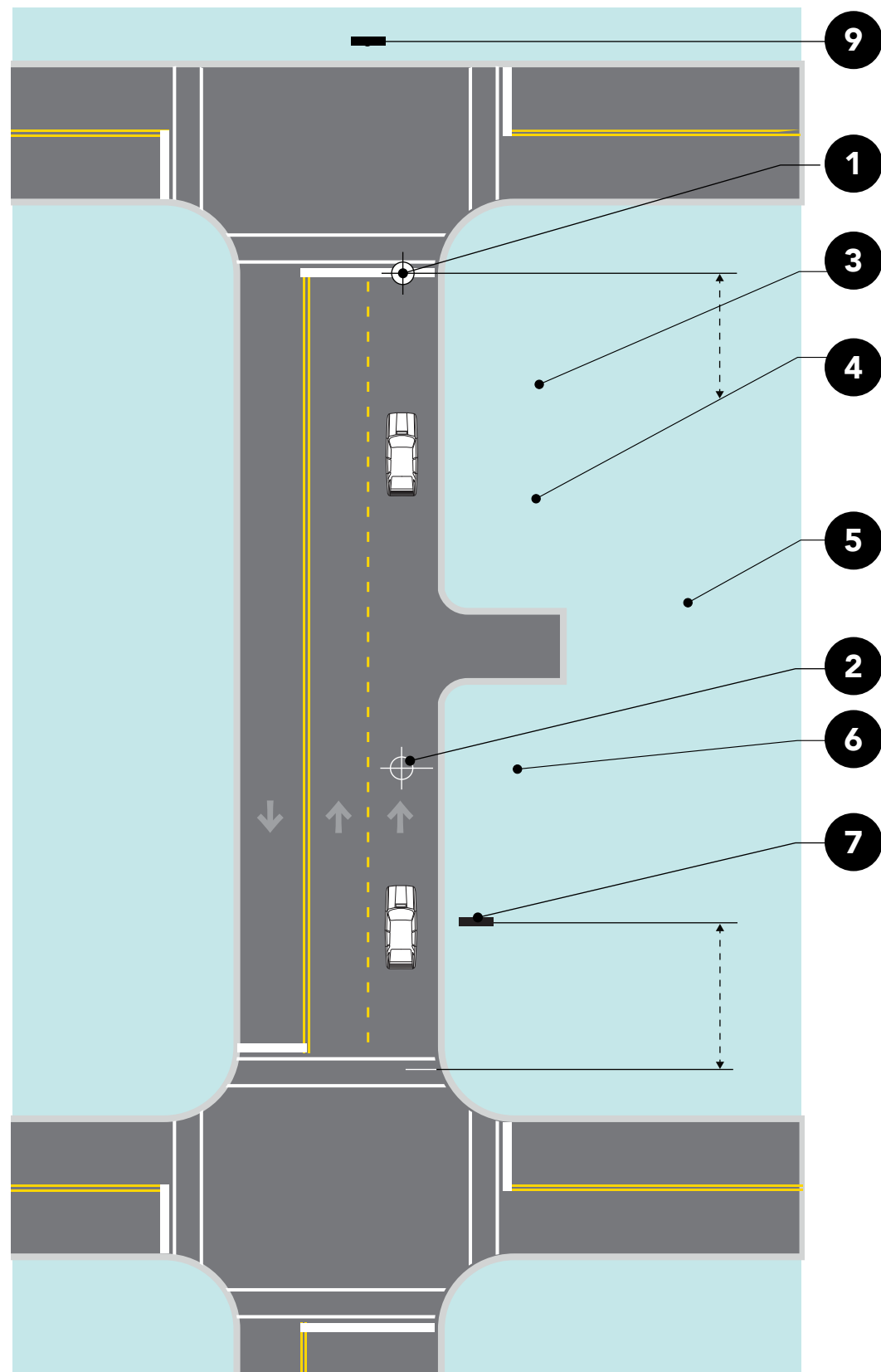

These standards are intended to establish consistency in trail design and application throughout the Fall Line Trail. As the system continues to grow, portions of the system may be constructed by different agencies. Establishing set standards for the placement of signage ensures that all new trail sections are consistent and meet the requirements expected.

### Vehicular Guide Sign Placement - Left Side of Street

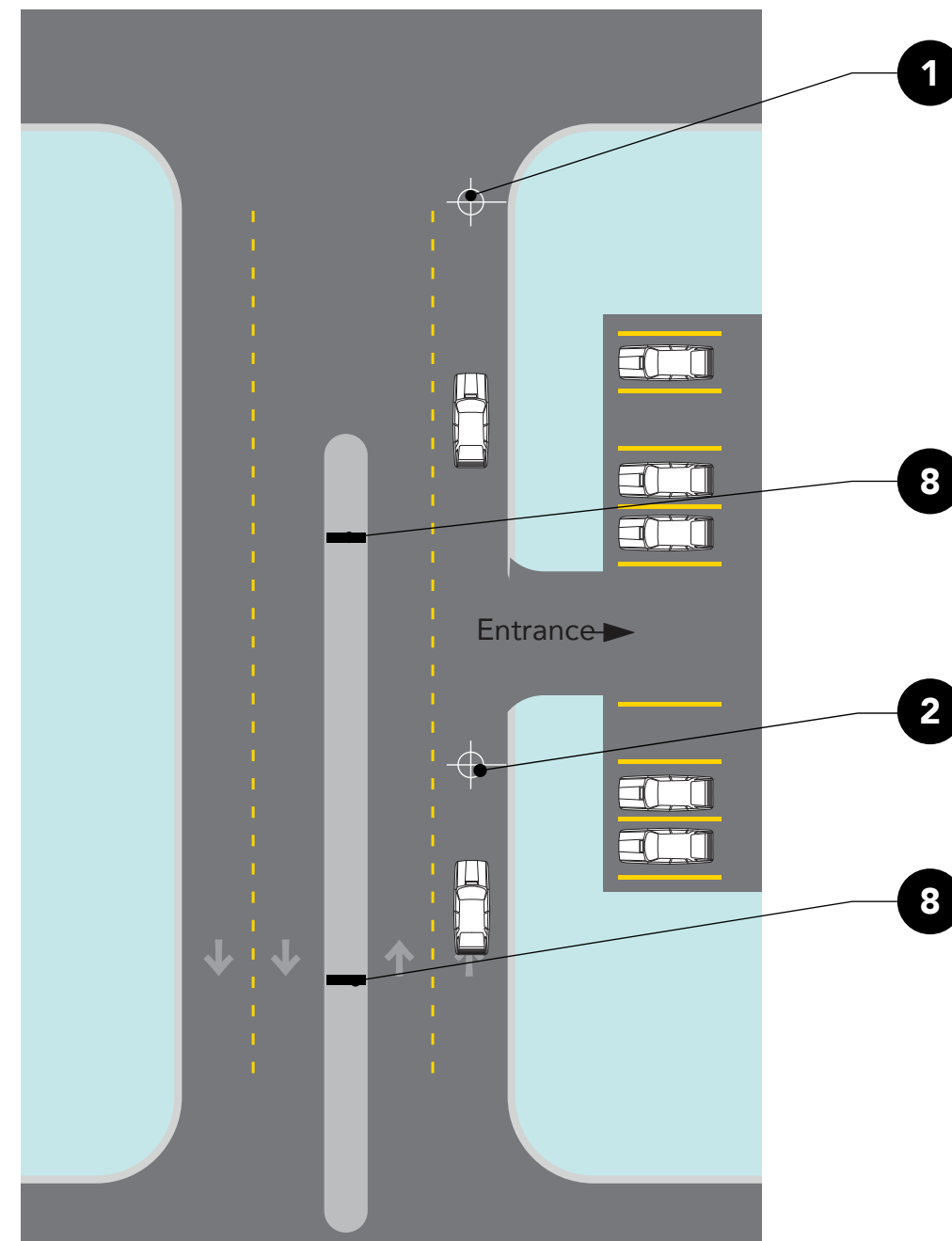

All signs shall be installed to the right of the direction of traffic and where sufficient space is available.

(a) Signs should be located to take advantage of natural terrain, to minimize impacts on scenic environment and to avoid visual conflicts with other signs, trees and lamp-posts within the City right-of-way.

(b) Signs shall be located so as not to interfere with, obstruct or divert driver's attention from any other Official Traffic Control Device. Other Official Traffic Control Devices placed at intersection approaches, subsequent to the placement of a Wayfinding Sign, shall have precedence as to location and may require the relocation of the Wayfinding Sign. In the locations where Official Traffic Control Devices are integrated into the Wayfinding Signage System, the Official Traffic Control Devices shall take precedence with regard to order, space and location, over other information.

(c) Wayfinding Signs should be positioned in such a manner that does not restrict driver's attention or view when making turns or driving through an intersection.

(d) There should be a goal of one sign per block, although two are permissible, where necessary.

(e) Final sign placement should be verified upon field study of existing conditions. Consult with the local transportation authority for compliance requirements.

### PLACEMENT GUIDELINES

1. In route decision point
2. Destination arrival decision point
3. Vehicular guide signs placed on the driver's right side of the street between 100 and 200 feet before an in-route decision point. If a speed limit is more than 50 mph, vehicular guide signs should be placed between 150 to 300 feet before an in-route decision point.
4. If a second vehicular guide sign is required before an in-route decision point, it may be placed no closer than 50 feet to the following sign. 100 feet is optimal.
5. Destination
6. Vehicular guide signs placed on the driver's right side of the street between 50 and 100 feet before a destination arrival decision point. If speed limit is more than 50 mph, vehicular guide signs should be placed between 100 to 150 feet before a destination arrival decision point.
7. A vehicular guide sign may be placed no closer than 50 feet from a preceding decision point or intersection. 100 feet is optimal.
8. Where the driver's right side of the street is not conducive for sign placement and a street is divided by a median wider than the width of a proposed sign and is not populated with visual barriers or is within the opposing traffic's line of site, guide signs may be placed on the driver's left side in the median. Distance from decision points as indicated
9. Where neither the driver's right or left side of the street is conducive for sign placement and the associated decision point occurs at a "T" intersection, guide signs may be placed on the far side of intersecting street as long as they do not conflict with existing signage, signal lights, store frontage or other critical visual devices.

NOTE: Placement distance between a vehicular guide sign and a decision point may vary depending on speed, number of lanes, congestion and competing visual elements and obstructions.

THIS DRAWING REPRESENTS DESIGN INTENT ONLY.

Date	Revisions	Scale
9.25.23		NTS

Client/Project  
CVTA, Virginia  
Wayfinding for Fall Line Trail

## PLACEMENT GUIDELINES

Perpendicular to Curb

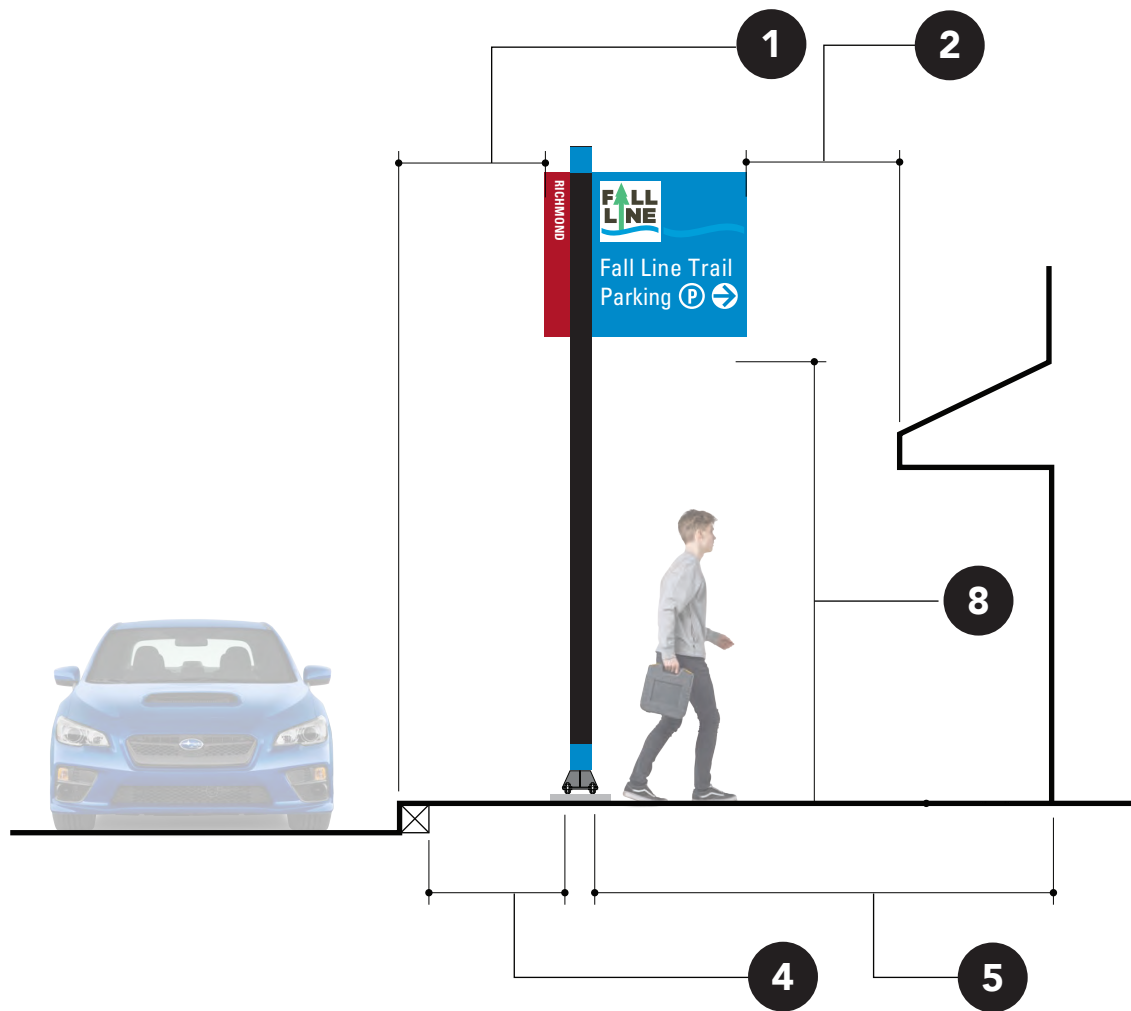

Parallel to Curb

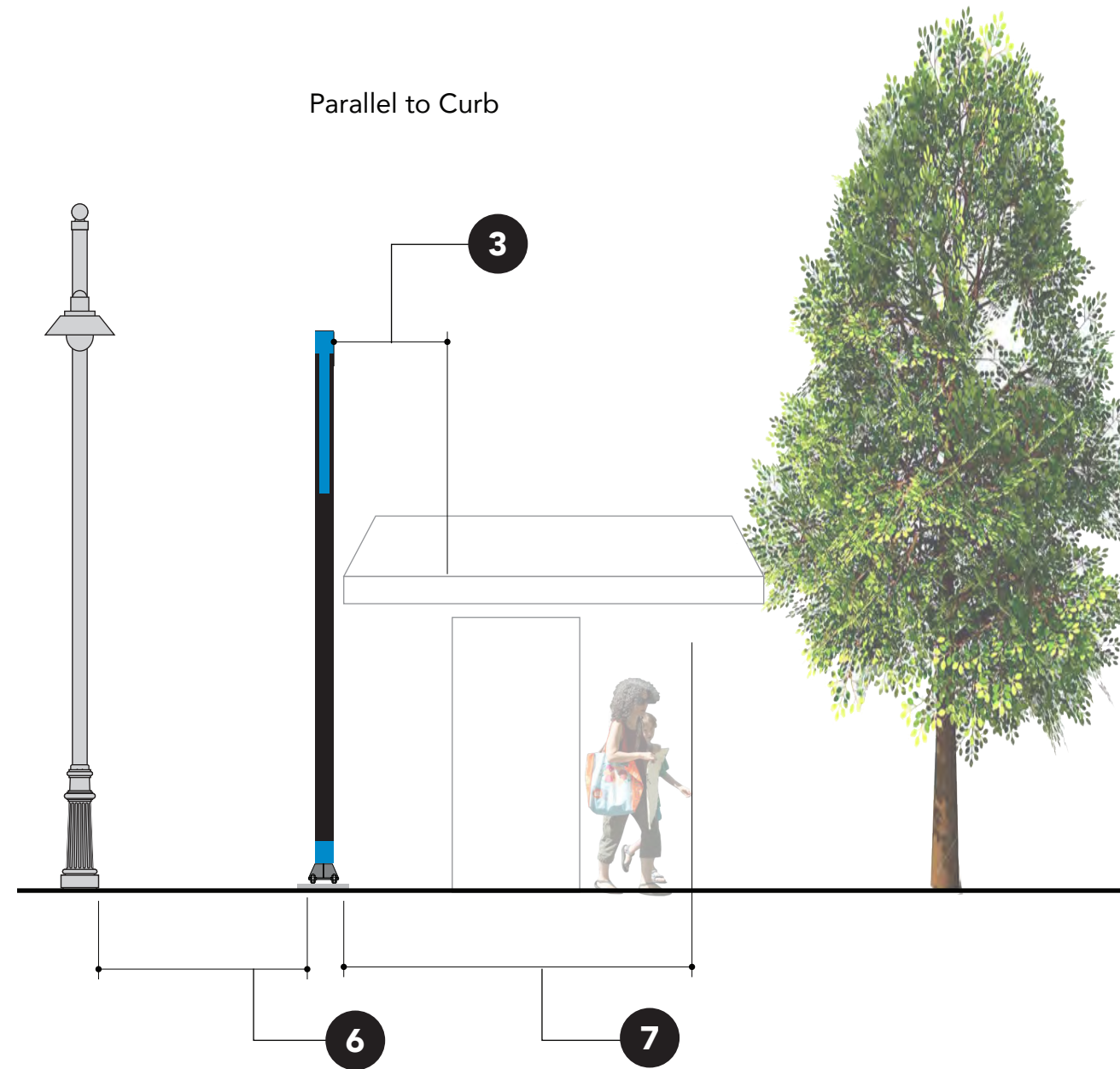

1. The distance from the curb to the outside edge of the sign panel must be no less than 1'-0".
2. The distance from the edge of the sign panel nearest to a building or projected element must be no less than 2'-0".
3. The front view of a vehicular guide must not obstruct its entrance.
4. If pedestrian traffic is only accessible between the outside edge of the vehicular guide post and the curb, the unobstructed path must be no less than 4'-0".
5. If pedestrian traffic is only accessible between the inside edge of the vehicular guide post and adjacent structures including open doors, the unobstructed path must be no less than 4'-0".
6. The distance from the back of the vehicular guide to the nearest utility pole must not be less than 10'-0" or the distance mandated by local code.
7. The distance from the front of the vehicular guide to the nearest tree or utility pole must not be less than 15'-0".
8. Maintain 7'-0" from grade to bottom of vehicular guide signs. Verify compliance requirements with the governing transportation authority.

THIS DRAWING REPRESENTS DESIGN INTENT ONLY.

Date	Revisions	Scale
9.25.23	5.29.24	NTS

Client/Project  
CVTA, Virginia  
Wayfinding for Fall Line Trail

## PLACEMENT GUIDELINES

Standard greenway cross-section:

1. The distance from the curb to the outside edge of the sign panel must be no less than 1'-0".
2. The trees must have a setback of 15' from the paved trail.

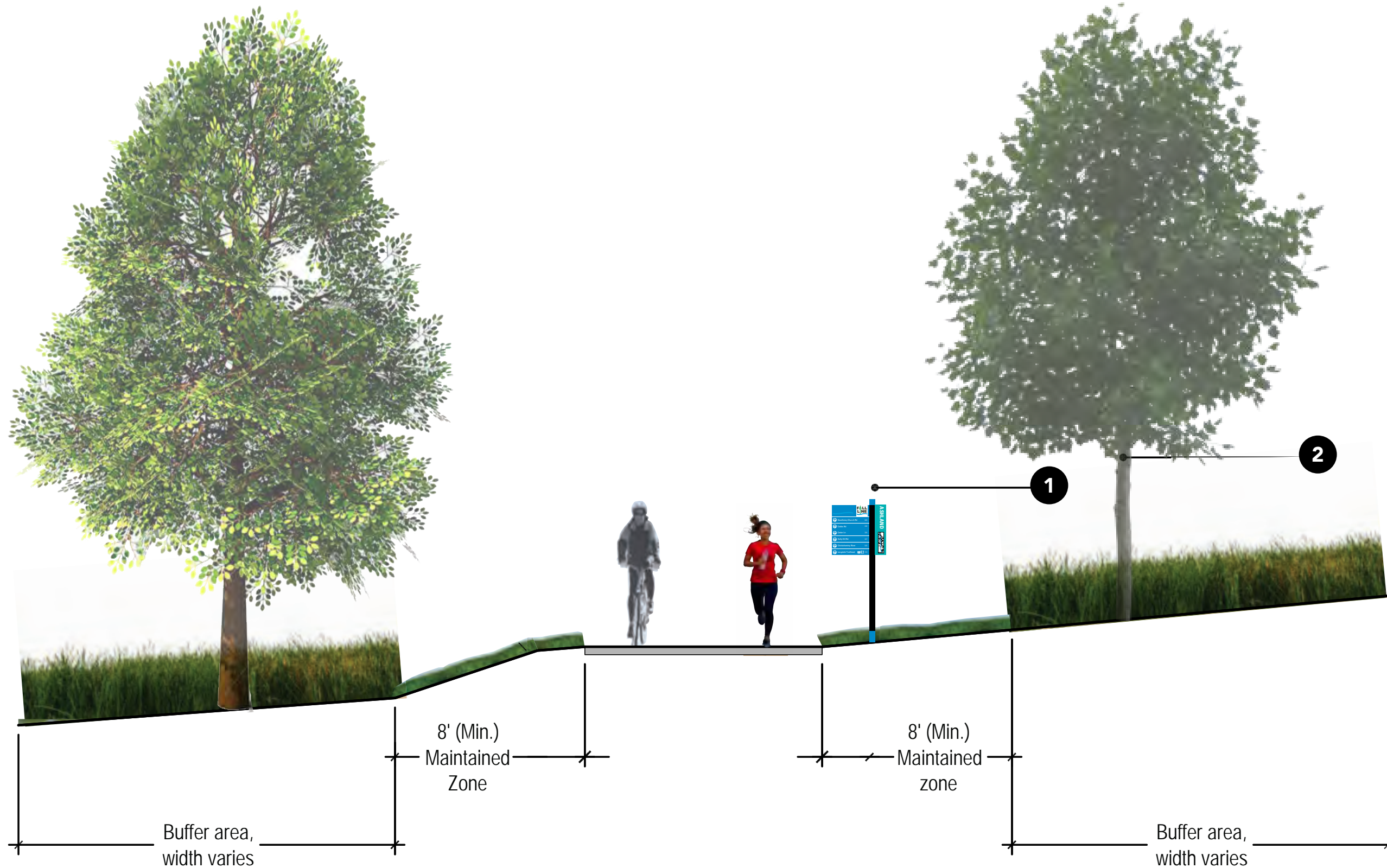

THIS DRAWING REPRESENTS DESIGN INTENT ONLY.

Date	Revisions	Scale
9.25.23	5.29.24	NTS

Client/Project  
CVTA, Virginia  
Wayfinding for Fall Line Trail

## PLACEMENT GUIDELINES

### Vegetation and Tree Guidance Requirements

Caution shall be given to sign placement in proximity to existing trees. Tree roots are commonly found 10" beneath ground level. The placement of the signage elements should be located at least 6' from any tree trunk.

Every effort shall be made to move any roots to the side of excavation. Works should be no closer than 40" from the tree base. Where excavations must be undertaken within four (4) times the tree circumference the use of mechanical excavations shall be prohibited within the precautionary zone.

**NOTE:** These drawings are meant for DESIGN INTENT ONLY and are not for construction. Contractor shall verify and be responsible for all dimensions and conditions of the job. Contractor shall be familiar with the site and conditions it presents. Shop drawings and details must be submitted prior to proceeding with fabrication. All copy shall be proofread by client and legal requirements checked by legal department.

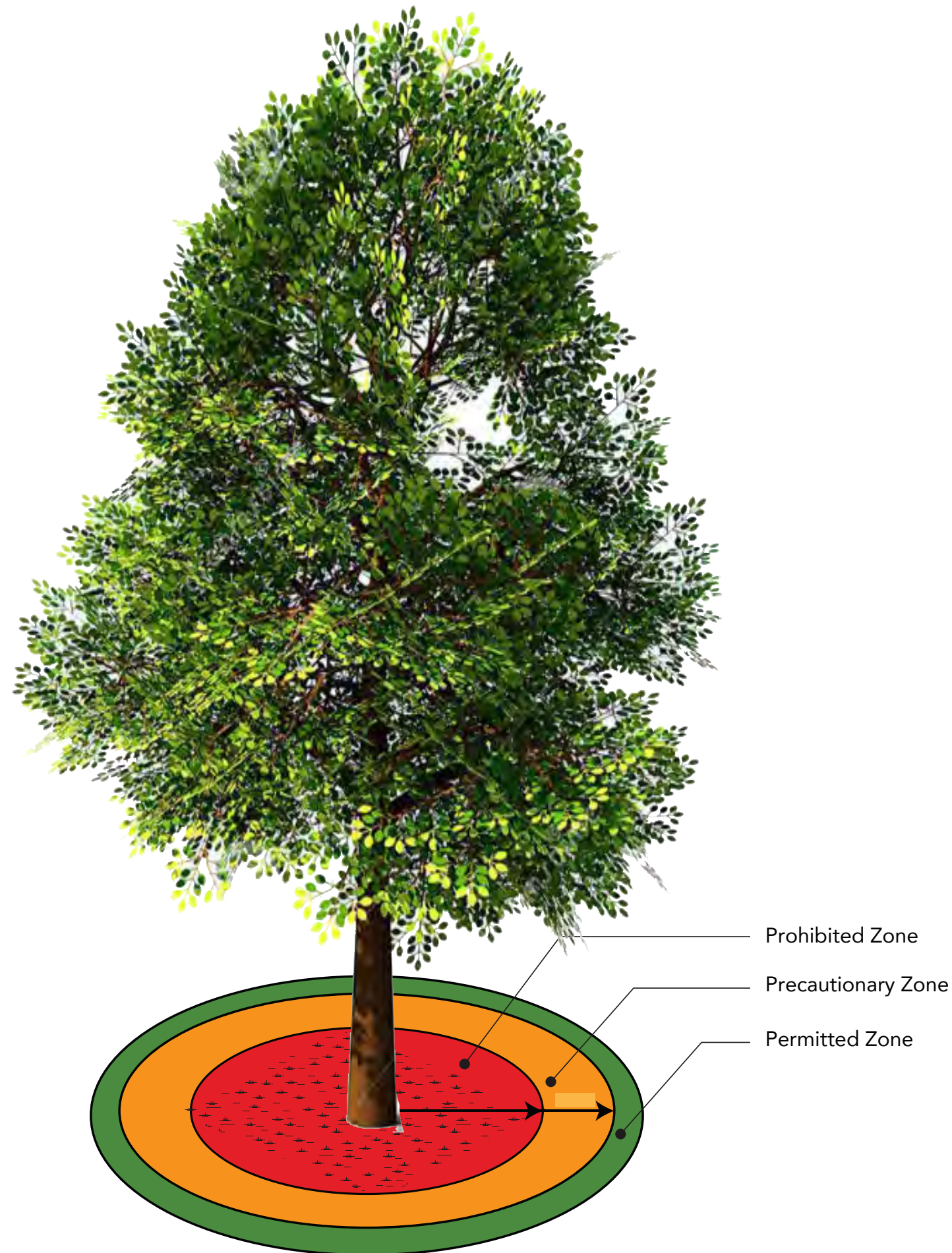

THIS DRAWING REPRESENTS DESIGN INTENT ONLY.

Date	Revisions	Scale
9.25.23		NTS

Client/Project  
CVTA, Virginia  
Wayfinding for Fall Line Trail





---

# Usage Guidelines

---

## Goals of the Signage Master Plan

We are pleased to present the Fall Line Trail Signage Master Plan.

### Signage Master Plan Standards Guidelines

In developing these Signage Master Plan standards, we have pursued the following goals and objectives:

- To develop an effective wayfinding system for pedestrians, bicycles, and short-term parking users that functions as an integral part of the trail environment.
- To use wayfinding to express the Fall Line Trail's unique culture, and image as it guides visitors to key destinations.

### The wayfinding system will:

- Provide effective wayfinding for pedestrians and bicycles between major destinations throughout the trail.
- Cultivate an overall "Sense of Place" for the community.
- Enhance and reinforce the unique experience for residents and visitors as they navigate the trail.
- Enhance and reinforce the boundaries of the trail with trailhead identity treatments.
- Provide all necessary information in a clear, concise, and minimal manner, while not adding to visual clutter.
- Be programmed and designed for phased implementation.
- Allow for ease of updating and maintenance.

One of the fundamental objectives of the Signage Master Plan is to clearly convey the identity and whereabouts of the landmarks within the Fall Line Trail.

The Plan proposes to use signage in a consistent manner throughout the Trail in order to guide visitors in a systematic fashion. This has the dual advantage of promoting the Trail and the diverse attractions within it.

An effective signage/wayfinding system functions not as a separate entity but as an integral part of its environment. Carefully planned signs communicate essential information while also enhancing the urban environment.

As the visual introduction to the community, signs play a prominent role in defining the trail's identity and boundaries.

The Signage Master Plan comprehensively details the correct use of the typography, colors, and the family of signs that comprise the wayfinding system.

Sign materials and finishes have been selected for their longevity. A color family has been selected to provide a comprehensive graphic visual language for the Fall Line Trail.

The wayfinding system has been designed to help first time and infrequent visitors with wayfinding and to define the trail's boundaries. Arrival Signage is important to establish a "Sense of Place."

Through the thoughtful use of this Signage Master Plan, signage and wayfinding will reinforce the link between the trail, the community, and the region.

This Signage Master Plan documents is an effort to provide a consistent wayfinding approach for the counties, and cities, and their attractions within the Fall Line Trail. The standards aim to promote a uniform approach to environmental communications – both in the visual image projected by signage and its content.

The wayfinding system outlined in this Signage Master Plan will provide many advantages to those who may wish or need to specify and procure signage products.

Users will find that this Signage Master Plan provides:

- Instructions on how to specify signage products to address a multitude of communication needs.
- Usage Guidelines for identification, orientation, directional, information, and regulatory signage.
- Assistance in the selection of colors, typefaces, and graphic motifs.
- Information on signage companies in the region that can produce these products.

The Usage Guidelines provide a structure for selecting the specific signage formats most applicable to the various types of information that need to be conveyed. Using these communication standards, visitors to the trail will experience consistency and predictability in the ways that wayfinding information is presented to them. This will not only provide a safer environment but one in which the visitors' needs have been anticipated and reflected in the placement and content of signs in the visual environment.

This Signage Master Plan should be used as an essential guide by trail staff and fabricators engaged in the sign system's planning, fabrication, installation, and maintenance. This document provides the necessary drawings and details required to implement the Signage Master Plan. Adherence to the standards in this Signage Master Plan will ensure consistency and a common visual language throughout the trail.

This Signage Master Plan is organized into sections:

- Graphic Standards
- Sign Drawings of each sign type
- Placement Guidelines
- Usage Guidelines
- Fabricators Guidelines
- Programming

# Usage Guidelines of the Signage Master Plan

## Fall Line Trail Wayfinding Standards & Signage Maintenance Manual Overview

As part of an ongoing effort to promote, and enhance the Fall Line Trail, a comprehensive Signage Master Plan has been developed. This effort includes an articulation of the manner in which orientation and direction-giving will be provided. User access and circulation throughout the Fall Line Trail will be facilitated by a standardization of signage as well as a consolidation of the nomenclature and circulation strategies.

The purpose of the Fall Line Trail Usage Guidelines of the Signage Master Plan is to provide consistency in both the appearance of communication devices and the content of wayfinding information. These guidelines aim to:

1. Preserve the appearance of signage
2. Standardize the specific materials and application technologies utilized in signage production
3. Streamline the procurement of signage components

In addition to this documentation, standards, and practices will be articulated that aim to ensure the consistency of the messages being communicated to Fall Line Trail visitors and prospective visitors.

These include:

1. Usage standards for each signage category
2. Nomenclature standards
3. Circulation strategies
4. Articulation of policies adopted for referencing destinations on orientation and directional signage
5. Electronic artwork for logos and symbols
6. Recommendations for utilization of wayfinding references among print and electronic marketing tools

The signage construction entails fabricated aluminum panels and steel posts, and vandal-resistant signfaces, some of them engineered to be removable and intended to be updated. The signs will utilize retro-reflective graphics.

### Strategy for Signage Implementation

The objectives for the signage system documented in this Signage Master Plan are to provide wayfinding information and reinforce the identity of the Fall Line Trail. This will be achieved through the implementation of visual, content, and location standards.

### Visual Design Standards

Despite the many counties, cities, parks, and attractions through which the trail passes, it is of paramount importance to maintain the formatting standards for all signage related to the Fall Line Trail. By maintaining this singular visual identity, the signage can underscore the autonomy of the Fall Line Trail.

There are several strategies for maintaining the visual standards:

1. Utilization of consistent signage categories. This involves the usage of specific formats for the various kinds of messages that need to be communicated.
2. Utilization of a consistent color scheme. The Trail logotype on the white background and the combination of blue background with white letters for the message section of the signs are arguably the most visible aspects of trail signage identity.
3. Usage of consistent logo and typographic layouts. The Fall Line Trail logo is used at the top of most wayfinding signage categories. Its particular sizing

and location are rendered for each signage format and are articulated in the Signage Drawings Section. Similarly, the fonts, layouts, and sizing of text on the various signs are also shown in the detailed drawings.

4. Usage of consistent map graphics.

### Content Standards

To ensure consistency in wayfinding, content standards have been established for the messages used for the various signage categories. Utilizing these standards will not only provide information where it is needed but also afford some predictability as to where this information is likely to be found on signs along the trail. The primary aspects of these content standards are:

1. Placement of specific kinds of information on accommodating signage formats. In essence, the signage formats have been designed around the information they need to convey. Detailed orientation information, for instance, is placed on pedestrian signs where people can pull off the trail and spend as much time as they wish to study maps and legends. Vehicular parking signs, on the other hand, use arrow symbols and copy sizes that permit to be seen without stopping.
2. Nomenclature standards. These standards aim to reinforce consistency, not merely among signage categories, but also print and electronic communications that reference the trail and the destinations that may be accessed from it.
3. Rationale for signage content. This involves recommendations for what specific kinds of information may be placed on wayfinding signage. Given the size of the trail and its many destinations, it is not functional to convey all of this information on any one sign. There are guidelines for what information may be utilized so that the signs can provide the necessary information and guidance without becoming excessively detailed or lengthy.

## Location Standards

The consistent placement of signage along the Fall Line Trail can contribute to both the identity of the trail and the function of its signage to provide guidance.

The “predictability” of signs at decision points and trailheads not only reinforces the fact that trail users are on the trail but also conditions them to look for and use the information provided. The standards for signage placement are:

1. Consistent with the MUTCD requirements for shared-use trails, no portion of any sign shall be closer to the edge of the trail than 24 inches. The standard adopted for the Fall Line Trail is the placement of directional and regulatory signs at 30” from the trail and orientation signs at 48”.
2. Where directional signage directs trail users from both directions, it is generally located as close as possible to the decision points. In the event a directional sign is directing visitors from only one approach, it is generally placed 20’ to 30’ in advance of the decision point.
3. Regulatory signage is included in the trailhead signs.
4. All signs should comply with state (VDOT), county, local, and MUTCD sign regulations that may apply.
5. The addition of off-trail trailblazer signs from main highways (e.g. 95, 64, 195 and 295) or main access roads (e.g. Parham Rd. and Chippenham Prkwy.) should be considered when the program is implemented.

## Fall Line Trail Autonomy

Although the Fall Line Trail will pass through numerous counties, and cities, parks and historical areas, this Master Plan intends to maintain the Fall Line Trail signage standards at the various access and decision points along its entire pathway. As the trail approaches parks or historical areas, directional signage will call out these destinations at a reasonable distance in advance. When the trail crosses into such areas, trail signage will acknowledge these boundaries. In reciprocation, we are hopeful that the signage within the parks, and historical areas will acknowledge the whereabouts of the Fall Line Trail in their own design vocabulary.

The most fundamental caveat of this system is that those signs that appear directly adjacent to the Fall Line Trail should reflect a singular identity to underscore the autonomy of this trail system and provide visual continuity to its users.

The use of the Fall Line Trail logo is an exclusive standard that defines the trail signage components, and may be used only for trail signage.

## Recommendations for Message Content

In order to establish communication consistency among the signage elements deployed along the Fall Line Trail, this section includes guidelines for the kinds of information that may be presented on directional and orientation signage. In terms of directional elements, the following guidelines are intended to create consistency in where such signs are placed along the trail, the types of destinations that are referenced, and the relative distances from which various destinations may be referenced.

## Directional Signage

### Proposed Criteria for Directional Signage Content and Placement

1. The purpose of directional signage will be to reinforce circulation along the Fall Line Trail.
2. It will be utilized at junctions/intersections with major roadways, pedestrian intersections or in proximity to trailhead/access points.
3. Directional Signage categories will include:
  - a. Vehicular Trailhead Sign (T1)
  - b. Vehicular Directional Sign (V1)
  - c. Urban/Parking Marker (U/P)
  - d. Banner Directional (Type B – pole mounted)
  - e. Pedestrian Trailhead (T2)
  - f. Pedestrian Directional (P1 & P2)
  - g. Landmark Identification Sign (ID)
  - h. Mile Marker (M)
  - i. Directional Sign (W)
  - j. Miscellaneous decals and ground signs
4. Vehicular directional signage will be placed in areas adjacent to the trail where the viewer may read the messages on approach without having to stop.
5. Pedestrian directional sign type P1 will be used if the sign is on a major road. Pedestrian directional sign type P2 will be used when the sign is located off the road or in a secondary road.
5. The content on directional signs will show directional arrows in the sequence of left, right, and straight ahead.
6. The content for directional signs may include:
  - a. Directional information
  - b. Key plan map of the entire Fall Line Trail
  - c. Welcoming information and regulatory information about the Fall Line Trail
  - e. Description of the conditions that exist along the local section of the Fall Line Trail, including segments on roadways, missing segments, portions under construction, hazards, and ADA-related information about trail accessibility

- 7. The content of the pedestrian directional signs will include information about distances.
- 8. Directional signage may be placed at trail access points, junctions/intersections with major roadways or intersecting trails, and areas where people frequently pass by or gather (e.g. restrooms, picnic areas, etc.).
- 7. Directional signage will be visible from the trail but be placed so that the viewer can safely stand off the trail and away from other pedestrian traffic areas to spend as much time as they wish to read the signage content.

**Destination Listing Recommendations**

Following below are the recommendations for listing various destinations on directional signage.

\* Note: Distances may vary somewhat based on attractions’ density (or scarcity) in a particular area.

Type of destination	Recommended distance to destination along trail or roadway/ trail leading to destination	Recommended distance from trail (*Fall Line Trail passes through or is adjacent to)
Neighboring Trail Sections (Ex. Henrico and North Richmond)	5 Miles	*
Municipalities (Ex. Ashland)	7 Miles	*
Trails ( Ex. Virginia Capital Trail)	1 Mile	*
Parks/Preserves (Ex. Appomattox Park)	1 Mile	1 Mile
Neighborhoods (Ex. Scott’s Addition)	One half Mile	*
Points of Interest (Ex. LG Botanical Garden)	One half Mile	1 Mile

**Map Graphic/ Legend Content**

- 1. The key plan map graphic will represent the entire Fall Line Trail with the viewer’s section highlighted. The map will also include major counties, and cities and highways.

**NOTE: Maps should always be oriented in the same direction as the viewer, not with the NORTH up, unless the viewer is facing north.**

**Destination List and Nomenclature Parameters**

**Destination List**

To ensure consistency among the wayfinding elements used throughout the Fall Line Trail, the following formal nomenclature will be utilized on signage. These terms will be applied to all signage elements as well as any print or electronic graphics developed as reinforcement. **The terms will be revised and updated on a regular basis to accommodate additions, deletions and changes to the attractions referenced.** This nomenclature was selected based on current usage for referring to locations. For example, Greenwood Park will be listed as Glover Park. Trailheads are marked in **Bold**. Schools will not be included as destinations

**FROM NORTH TO SOUTH**

**Ashland**

- Randolph Macon College
- Amtrak Train Station
- Secretariat Monument
- Downtown Ashland
- Hotels

**Carter Park Trailhead**

**Hanover County**

- Gwathmey Church Rd
- Cobbs Rd
- Cedar Lane Rd
- Chickahominy River

**Henrico County**

**Glover Park Trailhead**

- Virginia Center Commons
- Virginia Randolph Museum
- Crump Park
- Glen Allen Cultural Arts, and

- Reynolds Community College
- Glen Allen Softball Complex

**Longdale Trailhead**

- Henrico Sports and Events Center
- Mountain Road Fitness Track

**Garden City Trailhead**

- Green City
- St. Josephs Villa
- Belmont Recreation Center
- Brook Rd (Rte 1)
- Lakeside Avenue
- Lakeside Recreation Area
- Lewis Ginter Botanical Garden
- Brook Rd Neighborhood Park

**Spring Park Trailhead**

**Richmond**

**Bryan Park Trailhead**

- Diamond District (Spur)
- Brookland Parkway
- Virginia Union University
- Jackson Ward
- Downtown Richmond
- City Center (Spur)
- Richmond City Hall
- Capitol District
- Virginia State Capitol (Spur)

**Kanawha Plaza Trailhead**

- Browns Island
- Mayo Island/Richmond Main Street Station/ Shockoe Slip/Canal Walk/ Virginia Capital Trail(Spur)

**Central Business District**

- Manchester Bridge
- James River
- Manchester Climbing Wall
- South Richmond

**Broad Rock Creek Park Trailhead**

- Route 1 Richmond Highway

### Chesterfield County

#### Falling Creek Trailhead

Falling Creek Trailhead  
 Falling Creek Ironworks Park  
 Falling Creek Wayside Park  
 Bensley Park  
 Elk Viewing Platform

#### Fire Station 17 Trailhead

Willis Rd  
 Chester Village  
 Chester Library

#### Fire Station 1 Trailhead

Goyne Park

#### Solar Loop Trailhead

Fire Station 12  
 Ettrick  
 Amtrak Train Station  
 Virginia State University VSU

**Colonial Heights** (some destinations are in Chesterfield but will be displayed in the Colonial Heights section of the trail)

#### Lakeview Park Trailhead

Shepherd Stadium  
 Boulevard  
 Virginia State University VSU  
 Appomattox River Trail: VSU Trail  
 Appomattox River Trail  
 Appamattuck Park  
 Violet Bank Museum  
 Appomattox River  
 Southpark Mall (Spur)

### Petersburg

Appomattox River  
 Appomattox River Trail  
 Peter Jones Trading Station  
 Olde Towne Petersburg ( )  
 South Side Depot  
 Union Station  
 Centre Hill Mansion

#### Patton Park Trailhead

## Listing of Signage Categories

Below is a listing of Fall Line Trail signage categories documented as of October 2023. These are referenced in the Signage Drawings Section.

Category & Description:

- T1 Vehicular Trailhead Sign
- V1 Vehicular Directional
- U/P Urban Marker/Parking Marker
- B Banner
- T2 Pedestrian Trailhead Sign
- P1 Pedestrian Directional on Road
- P2 Pedestrian Directional off Road
- ID Landmark Identification
- M Mile Marker
- W Directional Sign
- VI Vinyl Decal
- PL1 Metallic Plate
- PL2 Metallic Plate
- G1 Ground Decal
- G2 Ground Stencil

Once signs are ordered and installed, it is crucial to compile a signage inventory for maintenance purposes and to easily track ownership.

The labeling system should represent a device's function, (e.g. P1) and an individualized item number. (e.g. P1.7). Each sign is assigned a unique number derived from this system and is used in the message schedule and sign location plan.

## Signage Usage Criteria

Outlined below are the criteria for utilizing each signage listed in the previous section. Detail drawings for each category appear in the Signage Drawings Section.

### TR1 Vehicular Trailhead Sign



#### Usage Criteria

This format shall be used on trailheads or main points of access to the trail where it is necessary to orient visitors to accesses to the trail parking areas.

This sign will include the name of the trailhead or access point, the locality in which the sign is located, parking information and parking symbol.

Sizing of copy and graphics shall follow the general guidelines illustrated in the sign drawings. This category may be located at primary trailheads parking areas adjacent to trailheads. The format includes graphics reflectivity. Signs can be one or two-sided.

### V1 Vehicular Directional



#### Usage Criteria

Types V-1 and V-2 shall be used to convey directional information to the trailheads parking. They should be located in advance of decision points.

The top section of the panel is reserved for trail identification and the lower section is available for directional content. The opposite side will display the locality in which the sign is located.

The format includes graphics' reflectivity. Signs can be one or two-sided.

### U/P Urban Marker /Parking Marker



#### Usage Criteria

This format shall be used when the trail has long stretches that overlap with a street, road, or avenue to convey that those paths are still part of the trail. This format shall be used as well along the trail to convey parking information at the trailheads and main access points for which public parking is available. They should be located in advance of the entrances to the parking.

The top section is reserved for trail identification and the lower section is available for content. The opposite side will display the name of the road or trailhead and display the locality color.

The format includes graphics' reflectivity. Signs can be one or two-sided.

### B Banner

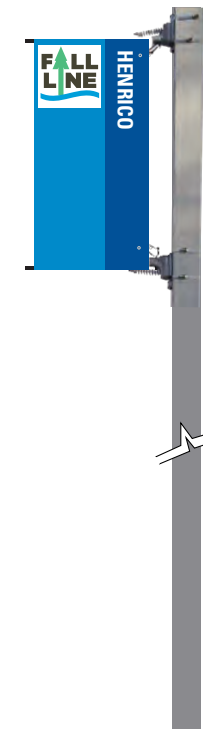

#### Usage Criteria

The Type B Banner Sign is intended to reinforce the route of the trail. The placement of these signs can be both along major vehicular circulation pathways as well as in paths on the trail itself. These may reinforce circulation (with an arrow) in certain situations, or simply identify the path of the trail. They will display the locality in which the sign is located.

This format is intended to be placed on existing utility or light poles. These banners represent a more economical alternative than vehicular or pedestrian free-standing signs as long as the specifications for the means of attachment are followed to avoid the banners being short-lived.

## T2 Pedestrian Trailhead / Regulatory Sign



### Usage Criteria

This format shall be used on trailheads and main points of pedestrian access to the trail. Symbols should be used to display amenities available at the particular trailhead.

The map section of the sign will include the full trail and display the locality in which the sign is located.

Sizing of copy and graphics shall follow the general guidelines illustrated in the sign drawings. This sign will include the name of the trailhead or access point, amenities information conveyed by symbols and regulatory information in the bottom part of the sign. In the section where the regulatory information is displayed, there may be a QR code linking to a website page with more specific regulations related to that section of the trail.

The format includes graphics' reflectivity. Signs can be one or two-sided.

## P1 Pedestrian Directional On Street

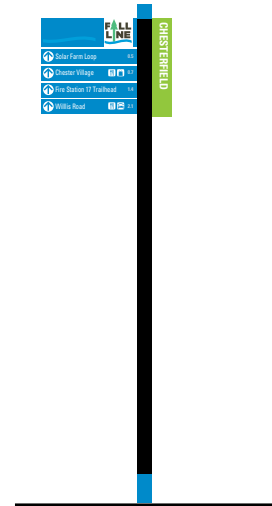

### Usage Criteria

Type P1 shall be used to convey directional, and distance information along the trail. They may be located at or slightly in advance of decision points and convey destinations of neighboring trail segments.

The top section is reserved for trail identification and the lower section is available for directional content. The directional information shall be included in independent changeable panels. P1 format to include the distance in miles to the highlighted destinations.

This format includes specifications for font and arrow size. The sign will include amenities information conveyed by symbols for some of the destinations as applies.

The format includes graphics' reflectivity. Signs can be one or two-sided.

## P2 Pedestrian Directional OffStreet



### Usage Criteria

Type P2 shall be used to convey directional, and distance information along the trail. They may be located at or slightly in advance of decision points and convey destinations of neighboring trail segments.

The top section is reserved for trail identification and the lower section is available for directional content. P2 format to include the distance in miles to the highlighted destinations.

The map section of the sign will include the full trail and display the locality in which the sign is located.

This format includes specifications for font and arrow size. The sign will include amenities information conveyed by symbols for some of the destinations as applies.

The format includes graphics' reflectivity. Signs can be one or two-sided.



**ID Landmark Identification**

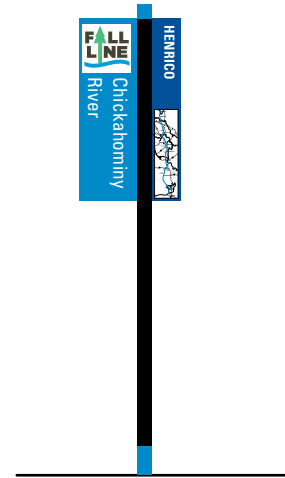

**Usage Criteria**

This format shall be used to identify mayor landmarks along the trail.

The top section is reserved for trail identification and the lower section is available for content.

The map section of the sign will include the full trail and display the locality in which the sign is located.

Sizing of copy and graphics shall follow the general guidelines illustrated in the sign drawings.

The format includes graphics' reflectivity. Signs can be one or two-sided.

**M Mile Marker**

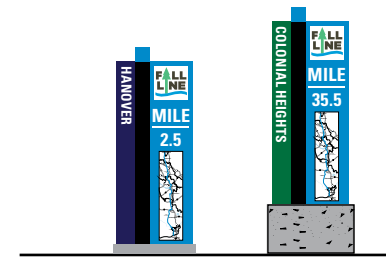

**Usage Criteria**

This format consists of a series of numbered markers placed along the trail at intervals of half a mile. They are typically located at the side of the trail. Mileage are measured as the distance from a fixed commencement point along the trail. The commencement point is the beginning of the 43-mile trail in Ashland.

This type will provide reference points along the trail.

This can be used to reassure travelers that the proper path is being followed and to indicate either the distance traveled or the remaining distance to a destination. Such references can also be used by maintenance and emergency services to direct them to specific points where their presence is required.

The top section is reserved for trail identification, and the lower section is available for the mile number and a map of the full trail. The opposite side will display the locality in which the sign is located.

The format includes graphics' reflectivity. Signs can be one or two-sided.

The alternative with the higher base will be used when flood levels in the area are high and the sign will need to be elevated.

**W Directional**



**Usage Criteria**

This format consists of a series of small signs placed along the trail to convey direction. They are typically located at the side of the trail.

This type will provide reference points along the trail

This can be used to reassure travelers that the proper path is being followed and to indicate whether the user is headed to the north or the south.

The top section is reserved for trail identification, and the lower section is available for content.

The format includes graphics' reflectivity. Signs can be one or two-sided.

**VI Vinyl Decal or Wrap**



**Usage Criteria**

This format consists of vinyl decals. They are typically located at existing posts or available flat surfaces along the trail. This type will provide reference points along the trail. This can be used to reassure travelers that the proper path is being followed. These signs should be low-cost versatile elements. They shall display the trail identification. The format includes graphics' reflectivity.

**PL1 & PL2 Metallic Plates**



**Usage Criteria**

This format consists of metallic plates. They are typically located at existing posts as top posts or on available flat surfaces along the trail. This type will provide reference points along the trail. This can be used to reassure travelers that the proper path is being followed.

These signs should be low-cost versatile elements. They shall display the trail identification.

**G1 Ground Decal**



**Usage Criteria**

This format consists of a large vinyl decal. This type will provide reference points along the trail. This can be used to reassure travelers that the proper path is being followed. They are typically located centered on the trail.

These signs should be low-cost versatile elements. They shall display the trail identification. The format can include graphics' reflectivity.

Other alternatives to include: metal medallions, thermoplastic, stamped concrete, and tile mosaics.

**G1 Ground Stencil**

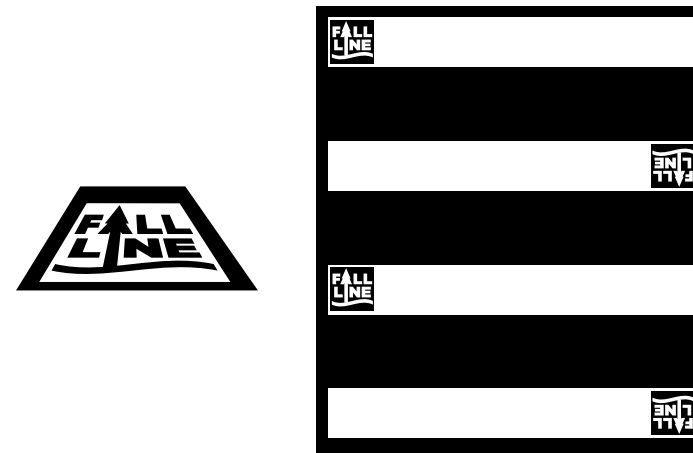

**Usage Criteria**

This format consists of a stencil in variable sizes that could be used at the continuation of the trail when it goes across roads or for branded crosswalks. This type will provide reference points along the trail. This can be used to reassure travelers that the proper path is being followed.

These signs should be low-cost versatile elements. They shall display the trail identification.

## Recommendations for Wayfinding Reinforcement Among Related Communications

While this document primarily focuses on preserving the Fall Line Trail's visual and content standards related to signage, there are opportunities to extend this communication continuity beyond the bounds of the trail itself. These opportunities may include electronic communications, promotional print graphics, and special displays or exhibits. The recommendations included below are intended to capitalize on the equity created with these standards and their potential to promote awareness and usage of the trail.

### Identity Graphics

The overall identity of the Fall Line Trail can be substantially reinforced among other forms of communication with effective use of the identity graphics.

### Content

Similarly, communication can be streamlined if specific references to the trail, destinations, and attractions are made consistently with the information that appears on signage.

This will entail:

1. Utilization of the nomenclature standards for destinations as shown in this document
2. Sharing the nomenclature and reference standards with counties, and cities, and stakeholders who are likely to make references to the Fall Line Trail.

## Listing of Recommended Vendors

Included below is a list of signage companies, that have previously worked with some of the localities and produced successful work that demonstrates their understanding and compliance with the products and application technologies included in the project documentation.

### **Color-Ad, Inc.**

Signs and Exhibits

7200 Gary Road, Manassas, VA 20109

703-631-9100

703-631-7849 Fax

Contact: SK Rao Senior Vice President

skrao@color-ad.com

703-631-9100 Ext. #3119

Mobile: 516-250-9661

www.color-ad.com

Fabricated signage for the city of Richmond and assisted in developing this master plan specifications

### **Superior Signs**

2510 Willis Rd

North Chesterfield, VA 23237

Phone: (804) 271-5685

www.superiorsignsrva.com

Fabricated signage for the Appomattox River Trail

## Maintenance Practices

To maintain consistency of the system as new signs are manufactured and installed, where specific signs and sign components are called for that are included in this Master Plan, these standards will be followed in all cases. Should any specific signage requirements exceed the size, content, or material requirements in this Master Plan, the Client will oversee the extrapolation of current design standards and coordinate the revision of the Master Plan to reflect the changes.

It will also review policy issues that impact signage and wayfinding on the Fall Line Trail. These may include:

1. Requests for new signage formats or departures from the existing standards
2. Coordination issues relating to what destinations are formally called and what pathways are used to guide visitors to access them
3. Apparent or potential wayfinding conflicts with other media
4. The coordination of temporary or short-term signage elements

With particular respect to signage hardware, the following maintenance schedule is recommended.

Bimonthly (March – November)

1. Order all new or replacement signage components.
2. Remove unauthorized signage.
3. Inspect all existing signage for wear and vandalism.
4. Repair or replace damaged signage.

Semi-Annually (April and October)

1. Update orientation and directional signage with respect to changes to nomenclature or circulation theory.
2. Review wayfinding standards to evaluate any needs identified for adjusting signage standards.
3. Review existing or planned projects to expand or upgrade the Trail and confirm that allowances are made to add or modify signage as required



---

# Fabricators Guidelines

---

## FABRICATOR PERFORMANCE & MATERIAL REQUIREMENTS

This document has been assembled by AB Design, Inc., for CVTA, VA (Owner), with the expectation that the Fabricator shall meet the following quality and performance requirements. The acceptance of these drawings by the Fabricator constitutes an agreement to comply with the following conditions. The Owner will hold the Fabricator to these requirements as part of their contract obligations.

### 1.0 GENERAL

#### 1.1 Related Documents

Sign Message Schedule/Programming, Sign Location Plan, and Drawings are all included in this document.

#### 1.2 Summary

The work includes the manufacture and installation of exterior signs. The Fabricator shall provide all labor, materials, equipment, and services necessary for the fabrication, delivery, and installation of signage as described in the design intent drawings, including all fasteners, connectors, hardware, and support structures, and as needed for a complete and proper installation.

The Fabricator is responsible for visiting the project site prior to starting the work and field verifying all existing conditions and dimensions, and shall notify the Owner immediately of any discrepancies.

Signs listed on Message Schedule/Programming should match those indicated on sign location plans. The Fabricator shall notify the Owner immediately of any discrepancies in sign quantities or locations.

#### 1.3 Design Intent Drawings

The "design intent" drawings contained in this document are for the sole purpose of expressing visual design intent, and are not intended for construction purposes. All aspects of fabrication, installation, and any resulting working drawings, shop drawings, submittals and contract documents are the responsibility of the

Fabricator. Within the design intent drawings:

- All written dimensions take precedence over dimensions otherwise implied by drawing scale, figures, etc.
- Large scale details take precedence over the smaller scale drawings.
- Specific recommendations for materials, colors, and content take precedence over representations shown in drawings.

Prior to the execution of the contract, the Fabricator shall carefully review all the Contract Documents, Design Intent Drawings, Specifications, and/or instructions for any conflicts or ambiguities. Fabricator will identify any conflicts or ambiguities in writing to the Owner prior to the execution of the agreement.

### 2.0 PRE-FABRICATION REQUIREMENTS

#### 2.1 Proposal

Copies of all pricing and bid information shall be sent to the Owner. The Fabricator shall base their proposal on the performance of all items of service including labor, operations, materials, accessories, incidentals, services, and equipment indicated, specified, mentioned, scheduled, or implied to complete fabrication and installation of the specified work. Full compliance with these Fabricator Performance and Material Requirements will be required. Any further examinations, investigations, explorations, tests, studies, and/or specifications necessary for the performance of the work and/or services required is the Fabricator's responsibility and should be accounted for in the bid and schedule.

Fabricator proposes and agrees to perform all work and/or services as specified in the bid and design intent documents for the prices and within the times indicated in the bid and in accordance with the other terms and conditions of the Contract. Fabricator is satisfied as to the general, local and site conditions that may affect the cost, progress, and performance of the work and/or services.

The Fabricator is encouraged to make recommendations for specific changes if they will improve the quality or

cost-effectiveness of fabrication while preserving the Designer's visual design intent. However, any such recommendations must be approved in writing by the Owner at the time of the bid. Should the Fabricator be contracted based on a proposal that assumes substitutions that have not been properly approved, the Fabricator shall be responsible for providing all elements as originally indicated at their own expense.

It is the responsibility of each Fabricator to verify the availability of material(s), delivery schedules, fabrication and manufacturing schedules, and other pertinent data prior to submission of their proposal, and the responsibility of the successful respondent to provide the same after the award of the project. It is the responsibility of the respondent to notify the Owner immediately if the material(s) specified are discontinued, replaced, or not available for an extended period of time. The Owner reserves the right to charge back additional costs, including but not limited to freight, special handling, and purchase price difference due to delays, etc., to the successful respondent when items are not supplied as proposed.

Fabricator-requested substitutions for any materials, products, colors, and components will only be considered for acceptance if the following conditions are met:

**Documented Delivery Problem:** The Fabricator must provide substantial written documentation to support a claim of a delivery problem which is in conflict with the fabrication/installation schedule, including but not limited to copies of correspondence to and from the product manufacturer which demonstrates that a delivery problem exists relative to the timely completion of the work. Delivery problems caused by the Fabricator or any subcontractor's failure to place orders for materials or items in a timely manner shall not be considered.

Requests for Substitution will NOT be considered during the Bid period. The Fabricator's bid shall be based on the Drawings and Specifications.

The Fabricator-requested product substitution will NOT be considered if the Fabricator or any subcontractor has delayed executing subcontract labor agreements or scheduling subcontract work from the time of the contract award.

Substitutions will NOT be considered when indicated on shop drawings or product data submittals without prior approval by the Owner.

Substitutions will NOT be considered when requested directly by a subcontractor or supplier.

Additional studies, investigations, submittals, redesign and/or analysis by the Architect/Engineer or Designer caused by the requested substitutions shall be paid by the Fabricator at no expense to Owner.

Substitute products shall NOT be ordered or installed without written acceptance by the Owner.

Requests For Substitution:

All Requests For Substitution submitted by the Fabricator shall include, for all products, finishes, or materials proposed to be substituted: Complete manufacturer's product specification information; Material Safety Data Sheet (MSDS); catalog information; full range of colors and options available as applicable; and documentation demonstrating that the substitute product is equal to the specified product.

Request For Substitution constitutes a representation that the Fabricator has investigated the proposed product and has determined that it is equal to or superior in all respects to the specified product.

Request For Substitution constitutes a representation that the Fabricator will provide the same type of warranty for Substitution as for the specified product.

The Fabricator's warranty shall be in writing, guaranteeing all substituted products have the same or superior performance as the product specified.

Request For Substitution constitutes a representation that the Fabricator will coordinate the installation of the accepted substitute, making such changes as may be required for the work to be complete in all respects.

The Fabricator shall state in writing the reason for the Request For Substitution; e.g., time, price, better quality, etc.

The Fabricator has given the Owner written notice of all conflicts, errors, ambiguities, or discrepancies that the respondent has discovered in the bid documents, and the written resolution thereof by the Owner is acceptable to the respondent. The bid documents are generally sufficient to indicate and convey an understanding of all terms and conditions for the performance of the work and/or services for which this bid is submitted.

## 2.2 Subcontracting

The Fabricator may utilize the services of specialty subcontractors on those parts of the work that, under normal contracting practices, are performed by specialty fabricators. The Fabricator must be able to perform a majority of the work at their own facility. Subcontractors shall have a supportive role to the project and should not individually or collectively have a higher percentage of work to perform than the Fabricator. The Fabricator shall be as fully responsible to the Owner for the acts and omissions of their subcontractors and of persons either directly or indirectly employed by them as the Fabricator is for the acts or omissions of persons directly employed by the Fabricator.

## 2.3 Shop Drawings

The Fabricator shall not begin fabrication without approved shop drawings, product data, and samples. Shop Drawings shall be submitted electronically (PDF).

The Fabricator shall provide complete fabrication and installation drawings for each type and version of sign and each installation condition, clearly mark drawings with sign type and location, and indicate all dimensions, materials, components, parts, connections, and devices.

Field-verified dimensions and conditions shall be included in shop drawings where applicable.

The Fabricator shall provide accurately scaled pattern layouts (in electronic format) for all signs of each type. All letter styles, fonts, and graphic elements shall be faithfully reproduced. Do not re-submit the Message Schedule/Programming drawings.

The Fabricator shall provide a copy of their stamped and signed Structural Design Drawings and Calculations, for record purposes only.

The Fabricator shall submit for review and approval shop drawings of all fabricated items, product data and samples to the Owner. This submission shall consist of detailed drawings that indicate all materials, finishes, construction details, lighting requirements, installation details, and artwork, including locations of all material seams. Drawings shall include elevations, plans, sections, and notes as required to clearly convey the fabrication intent.

The Designer shall advise and review all shop drawing submittals for fidelity and conformance with the design intent drawings. Upon review, the Fabricator shall make all requested revisions and re-submit as required. A complete set of approved shop drawings must be received from the Owner before production may begin. Required submittals must be issued in adequate time to coordinate a review and approval process without delaying the project schedule.

## 2.4 Artwork & Fonts

The Designer will provide the Fabricator with layout guidelines and electronic artwork as required. However, all final copy layouts are the responsibility of the Fabricator. The Fabricator shall legally acquire, at their own expense, all project fonts from the specified distributors, as necessary. The Designer will not provide copies of licensed fonts.

The message schedule in the Programming section is not final. Before fabrication, the Fabricator will have to confer with the Owner to get an approved revised version of the messaging for each of the signs and an approved location if there are variations from this original document due to changes that may have occurred between the issuing of this document and the date of the implementation of the different sections of the project. All letterforms shall match the sizing proposed and be aligned to maintain a baseline parallel to the signed format. Margins must be maintained as shown in the drawings.

### **2.5 Samples and Prototypes**

The Fabricator will provide samples of all paints, vinyls, and digital prints used in the project for review and approval by the Owner. The Fabricator will also supply to the Owner agreed upon prototypes for review of fabrication methods, finishes, and materials. Prototypes must be reviewed and approved before production. If approved, the prototype will be considered as part of the total sign count. If the prototype requires modifications, those changes must be made before it will be accepted. If the prototype is deemed to be defective and/or unfixable, based on the necessary modifications, the prototype will not be accepted as part of the final sign count. The Fabricator will be responsible for any costs needed to repair or replace defective prototypes.

### **2.6 Performance**

The Fabricator shall and will, in a good quality manner, do and perform all work and furnish all supplies and materials, machinery, equipment, facilities, and means, except as herein otherwise expressly specified, necessary or proper to perform and complete all the work required, within the time specified. The Fabricator shall observe, comply with, and be subject to all terms, conditions, requirements, and limitations of the contract and specifications and shall do, carry on, and complete the entire work to the satisfaction of the Owner.

Fabricators are expected to examine all Drawings, Specifications, instructions and/or requirements of this design intent document and corresponding documents. Failure to do so will be at the respondent's risk. All referenced documents must be considered in the preparation of the Fabricator's proposal. The Owner assumes no responsibility for errors or misinterpretations resulting from the use of the bid or design intent documents.

## **3.0 FABRICATION & INSTALLATION REQUIREMENTS**

### **3.1 Permitting & Regulation Compliance**

The Fabricator is responsible for securing and paying for all permits, insurances, inspections, and tests required by governmental agencies. The Fabricator is also responsible for verifying and ensuring compliance with all ADA, OSHA, environmental regulations, and all other applicable governing code requirements. The fabrication of signage shall be designed to meet local building codes, including ASCE 7, Basic Wind Speed of 130mph. The Owner must approve all required resolutions or revisions to construction details before production.

### **3.2 Structural Requirements**

The Fabricator shall follow the Designer's drawings for exterior visual appearance, but designs of internal structure, engineered connections, mounting assemblies, and foundations, are by the Fabricator. Structural design shall utilize self-supportive framing and prevent irregularities in exposed surfaces. The Fabricator shall provide the Owner with calculations for all structural members and foundations and they must be sealed by certified engineers registered in the state of Virginia prior to fabrication. The Fabricator shall provide the Owner and Designer with a list of support and/or blocking requirements, and approximate weights for each element, as required after final shop drawing approval. The Fabricator's installation responsibilities include the provision of any required footings, anchor bolts, or fastenings. All point-of-connection coordination is the responsibility of the Fabricator.

### **3.3 Labeling**

Visible labels, manufacturer's or otherwise, code permitting, shall not appear on any completed element. The placement of any required labels must be approved by the Owner prior to application and installation.

### **3.4 Delivery Storage and Handling**

Transport, deliver, handle, and store materials and equipment at the job site in a manner that prevents damage, including damage to finish and damage that might result from the intrusion of foreign matter or moisture from any source.

Packaging:

Maintain packaged materials in the manufacturer's original container with seals unbroken and labels intact until they are incorporated into the work. Protect finishes on exposed surfaces from damage by application of strippable temporary protective covering prior to shipment. Protect assemblies from injury at the shop, in transit to the job, and until erected in place, completed, inspected, and accepted. Packaged material shall bear the name of the manufacturer, and the product, including brand name, color, stock number, and all other complete identifying information.

Store all materials and equipment in accordance with the manufacturer's instructions, above grade, and properly protected from weather and construction activities. Include installation hardware, adhesives and installation instructions; include a reasonable array of alternate adhesives, fasteners or materials to be able to respond effectively to varying field conditions.

Within (14) business days of being awarded the contract, the Fabricator shall prepare and present to the Owner's Representative a schedule for submittals, reviews, fabrication, and installation of the work.

### **3.5 On-Site Coordination and Installation**

All installation will be coordinated with the Owner. No installation shall be permitted without sign-off of construction and final location approval through the Owner.

The Fabricator shall field verify all measurements indicated on drawings to establish correctness.

The Fabricator shall examine the site prior to executing this agreement so as to reasonably ascertain the nature of the work and the various conditions affecting the work. All locations shown in the enclosed location plans are approximate. The Fabricator is responsible for field verification and coordination of all final locations. The Fabricator shall notify the Owner of any discrepancies between the Designer's drawings, location plans, or message schedule, and field conditions prior to the sign fabrication. All required resolutions or revisions to construction details or installation processes must be approved by the Owner prior to production.

The Fabricator shall keep the site reasonably free from debris, trash, and construction wastes resulting from the performance of the work. The Fabricator shall be responsible for cleaning up all work areas upon the completion of work on a daily basis. Upon completion of the work, the Fabricator shall remove all debris, trash, construction wastes, materials, equipment, machinery and tools arising from the work. All finish surfaces at the base of the sign (lawn, mulch, brick, etc.) shall be repaired to match the existing finish grade.

All installed items shall be left in a clean and as-new condition. The Fabricator shall be fully responsible for the security and quality of all equipment, materials, and installed components until they have been reviewed and accepted by the Owner. All installations are to be level and plumb or will not be accepted. Immediately after erection, clean bolted connections and abraded areas of shop paint. Paint exposed areas with the same paint finish used for shop painting. If marred areas cannot be adequately touched up on site, the sign will be returned to the shop for controlled refinishing.

### 3.6 Inspection

At all reasonable times, the Fabricator shall provide sufficient facilities for inspection of the work by the Owner at the site and at all locations where

portions of the work are in progress or various stages of completion. When appropriate portions of the work are ready for inspection, the Fabricator shall notify the Owner.

### 3.7 Safety

The Fabricator recognizes the importance of performing the work in a safe manner so as to prevent damage, injury or loss to (i) all individuals at the site, whether working or visiting, (ii) the work, including materials and equipment incorporated into the work or stored on-site or off-site, (iii) the work of others on the project, and (iv) all other property at the site or adjacent thereto. The Fabricator assumes responsibility for implementing and monitoring all safety precautions and programs related to the performance of the work. The Fabricator shall be responsible for providing barricade or protective coverings as necessary to safeguard the public and property during the performance and duration of their work. The Fabricator shall be fully responsible for any injuries to the public or damage to the buildings, site, and adjacent objects during installation.

### 4.0 MATERIAL STANDARDS

The work shall comply with the highest relevant industry and trade standards, and standards as indicated in product sections of this specification.

All materials, hardware, and finishes used to fabricate any and all components shall be new (i.e. not previously used or operated in any other application) from the most recent manufacturer's production supply and free from any defects impairing strength, durability or appearance.

Use only personnel thoroughly skilled and experienced with the products and method for fabrication and installation of signage specified.

Materials and hardware not specified, but necessary to the complete functioning of the sign, shall conform to the quality level established.

### 4.1 Metals

Metals shall be the best commercial quality for the purposes specified and free from defects impairing strength, durability, or appearance. All joints must be welded, filled, ground, and sanded smooth prior to painting to insure an uniform surface. All sheet metal shall have brake formed edges with radii not greater than sheet thickness. All metals must be treated to prevent corrosion and staining of other finishes. All aluminum & steel materials must be thoroughly sanded to remove oxidation and primed prior to painting to ensure maximum paint adhesion.

### 4.2 Fasteners

All exposed fasteners shall be tamper-proof, resistant to oxidation and other corrosion, and painted to match adjacent surfaces. Concealed fasteners must be resistant to oxidation and other corrosion to prevent staining of other finishes. Nuts and bolts used on the footers and breakaway bases are to be anti-corrosive and galvanized.

### 4.3 Paints & Finishes

All paints and finishes shall match exactly the color, finish, and texture noted. The Fabricator is to apply primer, top coat, and clear coat to all painted surfaces as follows. Use Tape IT Accelerator SM166A as needed to speed up the drying process. Paint shall be:

- Metal Pretreatment 74 734SP
- Matthews Paint Conventional Topcoat
- Matthews Paint Satin Clear 42 228SP

Unless otherwise noted, all pretreats, primers, coatings, and finishes shall be applied in strict accordance with the paint manufacturer's specifications to provide the highest level of ultraviolet light resistance, weatherability, and overall longevity for both the materials indicated, and the environmental conditions of the final install locations. A polyurethane clear coating shall be applied to seal the paint and preserve the surface from wear and oxidation.



Paints and finishes shall be warranted against color fading, UV damage, cracking, peeling, blistering, and other defects in materials or workmanship for a minimum of five years from the date of the Owner's acceptance. All paints shall be evenly applied without pinholes, scratches, orange peeling, application marks, and other imperfections. Workmanship with finishes and formation of letters shall conform to the highest standards of the trade.

#### 4.4 Vinyl Film

All vinyl sheeting shall match exactly the color, finish, and durability of the manufacturer's product as noted. Unless otherwise noted, all vinyl sheeting shall be installed in strict accordance with the manufacturer's specifications to provide the highest level of ultraviolet light resistance, weatherability, and overall longevity for both the materials indicated, and the environmental conditions of the final install locations. Vinyl sheeting shall be warranted against color fading, UV damage, de-lamination, or peeling for a minimum of five years from the date of the Owner's acceptance. All vinyl cutting shall be executed in such a manner that all edges and corners of finished letter forms are true and clean.

3M™ High Intensity Prismatic Reflective Sheeting 3090DS (White) shall be used for all reflective sheeting printing. All signs shall be printed using only 3M™ Piezo Inkjet Series 8900UV Ink with an EFI H1625-RS printer. All sheeting surfaces shall be sealed with 3M™ Electrocut™ Film Series 1170 (Clear). All digitally printed vinyls shall be warranted from excessive fading, discoloring, cracking, crazing, peeling, and blistering for eight years from the fabrication date.

#### 4.5 Vinyl Banners

All product pieces shall be commercial-grade, heavy weight 18 oz, vinyl for the purposes specified and free from defects impairing strength, durability, or appearance. Unless otherwise noted, all materials shall be installed in strict accordance with the manufacturer's specifications to provide the highest level of overall

longevity. Vinyl to be mildew, water resistant, and fade resistant with double needle-lock stitching. Vinyl to be printed front and back. Printing to be high resolution. Products shall be warranted for a minimum of fifteen years from the date of the Owner's acceptance.

#### 4.5 Bannersaver® Systems

All product pieces shall be the best commercial quality for the purposes specified and free from defects impairing strength, durability, or appearance. All exposed fasteners shall be tamper-proof and painted to match the specified paint. Products shall be warranted for a minimum of thirteen months from the date of the Owner's acceptance. Products shall be acquired at:  
<https://britteninc.com/>  
<https://bannersaver.com/>

#### 5.0 PROJECT COMPLETION

##### 5.1 Review & Punch List

The Fabricator shall notify the Owner in writing when all work is completed. Upon notice, the owner will review all work according to their contract, and prepare a punch list outlining incomplete or unsatisfactory items. The repair or replacement of work outlined on the punch list shall be coordinated between the Fabricator and the Owner. The Fabricator shall correct any of the work that is found not to be in conformance at their own expense.

##### 5.2 Correction of Work

All work, all materials, whether incorporated in the work or not, all processes of manufacture, and all methods of construction shall be at all times and places subject to the inspection of the Owner who shall be the final judge of the quality and suitability of the work, materials, processes of manufacture, and methods of construction for the purposes of which they are used. Should they fail to meet the Owner's approval, they shall be forthwith reconstructed, made good, replaced and/or corrected, as the case may be, by the Fabricator at the Fabricator's expense. Rejected material shall immediately be removed from the site. If, in the opinion of the Owner, it is undesirable to replace any defective or damaged

materials, or to reconstruct or correct any portion of the work injured or not performed in accordance with the contract documents, the compensation to be paid to the Fabricator shall be reduced by such amounts as in the judgment of the Owner shall be equitable.

#### 5.3 Final Deliverables

Upon the Owner's acceptance of the work, the Fabricator shall provide the Owner with a complete service and maintenance manual for all products and finishes installed under their contract. This manual shall include, but is not limited to, product specifications, such as manufacturer information, contact names and addresses, warranty information, technical data, and routine maintenance recommendations.

#### 5.4 Warranties

All warranty periods shall begin on the date of the Owner's acceptance of the work. All warranties shall include the materials and labor required to replace defective components. All installed elements shall be warranted against manufacturer defects for a minimum of one year, and all installed elements shall be warranted against defects in installation or workmanship for a minimum of three years.

#### 6.0 Proprietary Information Non-Disclosure Agreement

All ideas, designs, arrangements, and plans indicated or presented by these drawings are the property of the Owner and were created for use in connection with the specified project.

The Fabricator must request and receive written approvals from the Owner to use images of any completed element. The Fabricator is responsible for ensuring that credit indicating the Designer as the Designer will accompany all images and articles related to the project. The Owner may have additional requirements or restrictions for which the Fabricator is also responsible.



---

# Process Flow Chart

---

# PROCESS FLOW CHART FOR SIGNING A REGIONAL TRAIL

**START**

**PROCESS 01**  
When it is the implementation time, evaluate the proposed Master Plan

**01**

**PROCESS 02**

Update messages if there were any changes. The messages have to remain consistent throughout the trail.  
(Check the number of characters that fit on the signs and use abbreviations when necessary)

**02**

**PROCESS 03**

Update the sign types if necessary (refer to the usage guidelines section of the Standards Manual)

**03**

**PROCESS 04**

Update the locations of the signs if there were any changes

**04**

**PROCESS 05**  
Add signs if necessary (refer to the usage guidelines section of the Standards Manual)

**09**

**PROCESS 08**

Evaluate the sign location plan and sign messages on-site

**07**

**PROCESS 07**

Check messages for consistency and spelling

**06**

**PROCESS 06**

Establish destination mileage for new and/or changed signs

**05**

**PROCESS 09**  
Prepare a sign location plan and a message schedule for bidding

**09**

**PROCESS 10**

Evaluate bids and compare pricing

**10**

**PROCESS 11**

Award the project to a sign fabricator

**11**

**PROCESS 12**

Supervise the installation of the signs

**12**

**PROCESS 13**  
Generate a punch list and make good

**FINISH**

# DESTINATIONS FORM NORTH TO SOUTH

*The destination may not be in a particular locality but if it can be accessed from that locality is listed there (e.g. VSU is in Chesterfield, but it can be accessed form Colonial Heights).*

## GENERAL NOTES:

**NOTE:** copy in red indicates primary destinations.

Primary destinations are those located on or adjacent to the trail.

**Bold red indicates a trailhead.**

Copy in blue indicates future connected destinations. *Copy in orange and Italics indicates symbols.*

## From North to South

Randolph Macon College (N)

Amtrak Station (N) *Train*

Secretariat Monument (N)

Downtown Ashland (N) *Restaurants/Retail*

Hotels (N)

### **Carter Park Trailhead**

Gwathmey Church Rd

Cobbs Rd

Cedar Lane

Chickahominy River (in the border with Henrico)

Glover Park

Virginia Center Commons *Restaurants/Retail*

Virginia Randolph Museum

Crump Park

Glen Allen Cultural Arts, and

Reynolds Community College

Glen Allen Softball Complex *Softball*

**Longdale Trailhead** *Fitness/Restrooms*

Henrico Sports and Events Center

Mountain Road Fitness Track *Fitness*

**Garden City Trailhead** *Fitness/Restrooms*

Green City

St. Josephs Villa

Belmont Recreation Center *Golf*

Brook Rd (Rte 1) *Restaurants/Transportation*

Lakeside Avenue *Restaurants/Retail*

Lakeside Recreation Area *baseball*

Lewis Ginter Botanical Garden

Brook Rd Neighborhood Park

**Spring Park Trailhead** *Restrooms*

### **Bryan Park Trailhead**

Diamond District Spur

Brookland Parkway

Virginia Union University

Jackson Ward

Downtown Richmond/ City Center Spur

Richmond City Hall

Capitol District - Spur Virginia State Capitol

Shockoe Heritage Site

### **Kanawha Plaza Trailhead**

Browns Island

Mayo Island Spur / Richmond Main Street Station / Shockoe Slip / Canal Walk / Virginia Capital Trail Central

Business District

Manchester Bridge

James River

Manchester Climbing Wall

South Richmond

### **Broad Rock Creek Park Trailhead**

Route 1 Richmond Highway

### **Falling Creek Trailhead**

Falling Creek Wayside Park

Bensley Park

Elk Viewing Platform

Willis Rd *Restaurants/Hotel*

### **Fire Station 17 Trailhead**

Chester Village *Restaurants/Retail*

Chester Library

Goyne Park

### **Fire Station 1 Trailhead**

### **Solar Loop Trailhead**

Fire Station 12

Ettrick *Restaurants/Retail* Amtrak

Train Station

VSU

### **Lakeview Park Trailhead**

Shepherd Stadium (E)

Boulevard E) Access through Roanoke Ave & Lakeview Ave after leaving Lakeview Park *Restaurants/Retail*

VSU (W and S)

Appomattox River Trail: VSU Trail

Appomattox River Trail Appamattuck

Park (E)

Violet Bank Museum (E) (through Appomattox River Trail)

### **Appomattox River**

Old Towne Petersburg from the Colonial Heights side of the river and then via the MLK bridge (has sidewalk)

Southpark Mall area via the ART (E)

**Appomattox River**

Virginia State University (N) .1 Mile

Appomattox River Trail *Walking/Biking*

Peter Jones Trading Station/Tavern Park (E)\* .5 mil

Olde Towne Petersburg (E) *Restaurants/Retail* .5 mil

South Side Depot (E) *Train* .8 mil

Union Station (E) *Train* 1 mil

Centre Hill Mansion (E) 1 mil

**Patton Park Trailhead**

\*Peter Jones Trading Post

Peter J. Trading Station

Peter J. Trading Post Peter Jones (If it

has to be that short)